

# Preventing in-source fragmentation of Atreleuton-d4

**Author:** BenchChem Technical Support Team. **Date:** April 2026

## Compound of Interest

Compound Name: Atreleuton-d4

Cat. No.: B12362281

[Get Quote](#)

## Technical Support Center: Atreleuton-d4

Welcome to the Technical Support Center for **Atreleuton-d4**. This resource is designed for researchers, scientists, and drug development professionals to provide guidance on preventing in-source fragmentation of **Atreleuton-d4** during mass spectrometry analysis.

## Troubleshooting Guide: In-Source Fragmentation of Atreleuton-d4

In-source fragmentation (ISF) is a common phenomenon in mass spectrometry where a precursor ion fragments in the ion source before entering the mass analyzer. For deuterated standards like **Atreleuton-d4**, this can lead to inaccurate quantification and misinterpretation of data. This guide provides a step-by-step approach to identify and mitigate ISF.

Issue: Appearance of Unexpected Fragment Ions and Reduced Precursor Ion Intensity

If you observe fragment ions that could correspond to the loss of parts of the **Atreleuton-d4** molecule and a simultaneous decrease in the intensity of the target precursor ion, you are likely encountering in-source fragmentation.

### Step 1: Confirm In-Source Fragmentation

To confirm that the fragmentation is occurring in the ion source and not in the collision cell, perform a direct infusion of an **Atreleuton-d4** standard solution. Acquire data in full scan mode without applying any collision energy. If you still observe the fragment ions, it confirms in-source fragmentation.

### Step 2: Optimize Ion Source Parameters

In-source fragmentation is primarily caused by excessive energy being transferred to the ions in the ion source.<sup>[1]</sup> The two main parameters to adjust are the cone voltage (also known as declustering potential or fragmentor voltage) and the ion source temperature.<sup>[1]</sup>

- **Cone Voltage/Declustering Potential/Fragmentor Voltage:** This is the most significant contributor to ISF. A higher voltage increases the kinetic energy of the ions, leading to more energetic collisions with gas molecules and causing fragmentation.<sup>[2]</sup>
  - **Action:** Systematically decrease the cone voltage in small increments (e.g., 5-10 V) and monitor the intensity of the precursor ion and the fragment ions. The goal is to find a voltage that maximizes the precursor ion signal while minimizing the fragment ion signals.
- **Ion Source Temperature:** Higher source temperatures can provide additional thermal energy, promoting the fragmentation of labile molecules.<sup>[1]</sup>
  - **Action:** Reduce the ion source temperature in increments of 25-50°C and observe the effect on the precursor and fragment ion intensities.

### Step 3: Evaluate Mobile Phase Composition

The composition of the mobile phase can influence ionization efficiency and the stability of the generated ions.

- **Action:** If possible, try altering the mobile phase composition. For example, adjusting the pH or the organic solvent ratio might help to stabilize the precursor ion.

### Step 4: Consider a Different Ionization Technique

If optimizing the above parameters does not resolve the issue, consider if a "softer" ionization technique is available and compatible with your experimental setup. Electrospray ionization (ESI) is generally considered a soft ionization method, but atmospheric pressure chemical ionization (APCI) or atmospheric pressure photoionization (APPI) might be even gentler for certain compounds.[3]

## Frequently Asked Questions (FAQs)

Q1: What is in-source fragmentation (ISF)?

A1: In-source fragmentation is the process where molecular ions break down into smaller fragment ions within the ion source of a mass spectrometer, before they are separated by the mass analyzer.[1] This is in contrast to collision-induced dissociation (CID), which intentionally occurs in the collision cell of a tandem mass spectrometer.

Q2: Why is in-source fragmentation a problem for quantitative analysis using **Atreleuton-d4**?

A2: When **Atreleuton-d4** is used as an internal standard, accurate quantification relies on the precise measurement of the precursor ion's signal intensity. If **Atreleuton-d4** undergoes in-source fragmentation, the intensity of the intended precursor ion is reduced, which can lead to an inaccurate analyte-to-internal standard ratio and compromise the quantitative accuracy of the assay.[2]

Q3: What are the most likely fragmentation pathways for **Atreleuton-d4**?

A3: Based on the structure of Atreleuton, which contains a thiophene ring, a fluorophenyl group, and a hydroxyurea moiety, the most probable sites for fragmentation are the bonds adjacent to these functional groups. The N-O bond in the hydroxyurea group is particularly labile and prone to cleavage. Cleavage of the bond between the thiophene ring and the butynyl chain is also a possibility.

Q4: Can the deuterium labels on **Atreleuton-d4** be lost through in-source fragmentation?

A4: While the primary concern with deuterated standards is often H/D exchange with the solvent, in-source fragmentation can also lead to the loss of the deuterium label if the fragmentation occurs at or near the site of deuteration.[4] This would result in an ion that has

the same mass as an unlabeled fragment, potentially interfering with the analysis of the native analyte.

Q5: How can I differentiate between in-source fragmentation and contamination?

A5: To differentiate between ISF and a contaminant, analyze a fresh, certified standard of **Atreleuton-d4**. If the unexpected peaks are still present and their relative intensities change with adjustments to the ion source parameters (cone voltage, temperature), they are likely due to ISF. If the peaks remain constant regardless of source conditions, they may be due to an impurity in the standard or a contaminant in the system.

## Data Presentation

Table 1: Effect of Cone Voltage on **Atreleuton-d4** Ion Intensities (Hypothetical Data)

Cone Voltage (V)	Precursor Ion Intensity (cps)	Fragment Ion X Intensity (cps)	Fragment Ion Y Intensity (cps)
10	500,000	5,000	2,000
20	800,000	15,000	5,000
30	1,200,000	40,000	15,000
40	900,000	150,000	50,000
50	600,000	400,000	150,000

This table illustrates a typical trend where the precursor ion intensity initially increases with cone voltage and then decreases as in-source fragmentation becomes more pronounced.

Table 2: Effect of Ion Source Temperature on **Atreleuton-d4** Ion Intensities (Hypothetical Data)

Source Temperature (°C)	Precursor Ion Intensity (cps)	Fragment Ion X Intensity (cps)	Fragment Ion Y Intensity (cps)
300	1,100,000	35,000	12,000
350	1,150,000	45,000	18,000
400	1,200,000	60,000	25,000
450	1,050,000	100,000	45,000
500	850,000	250,000	90,000

This table shows how increasing the source temperature can lead to a decrease in the precursor ion signal and an increase in fragment ion signals.

## Experimental Protocols

### Protocol 1: Systematic Optimization of Cone Voltage to Minimize In-Source Fragmentation

- **Prepare a Standard Solution:** Prepare a solution of **Atreleuton-d4** in a solvent composition that is representative of your mobile phase. A typical concentration would be in the range of 100-1000 ng/mL.
- **Direct Infusion Setup:** Infuse the standard solution directly into the mass spectrometer at a constant flow rate (e.g., 5-10  $\mu$ L/min).
- **Initial Mass Spectrometer Settings:** Set the ion source temperature to a moderate value (e.g., 350°C) and the capillary voltage to an appropriate setting for your instrument. Set the collision energy to zero.
- **Cone Voltage Ramp:** Acquire full scan mass spectra at a series of cone voltage settings. Start with a low value (e.g., 10 V) and increase it in increments of 5 or 10 V up to a high value (e.g., 80 V). Allow the signal to stabilize at each new voltage setting before acquiring data.
- **Data Analysis:** For each cone voltage setting, record the intensity of the **Atreleuton-d4** precursor ion and any significant fragment ions.

- Optimal Cone Voltage Selection: Choose the cone voltage that provides the highest intensity for the precursor ion while keeping the intensity of the fragment ions to a minimum.

## Mandatory Visualization

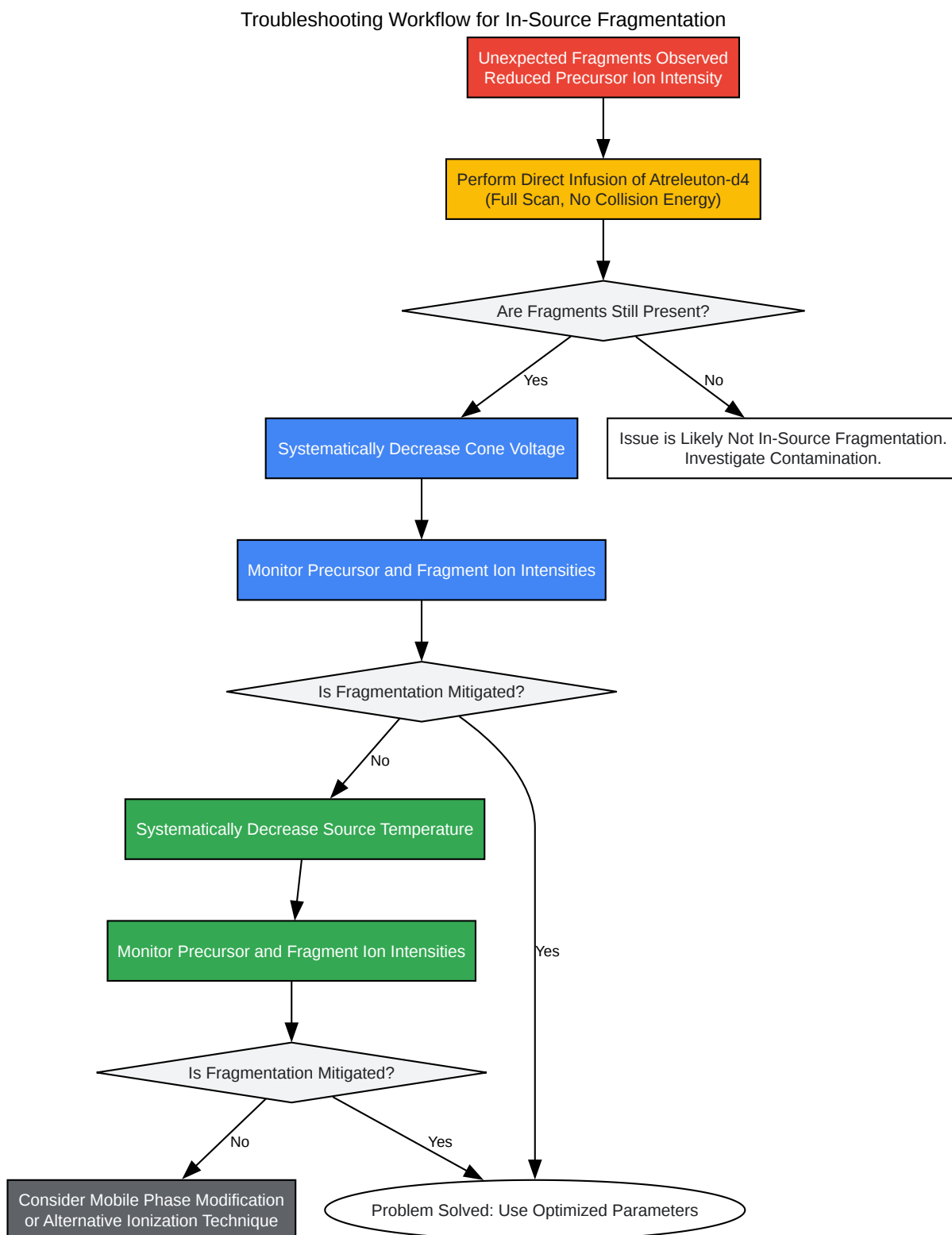

[Click to download full resolution via product page](#)

Caption: Troubleshooting workflow for identifying and mitigating in-source fragmentation.

## Proposed In-Source Fragmentation Pathway of Atreleuton-d4

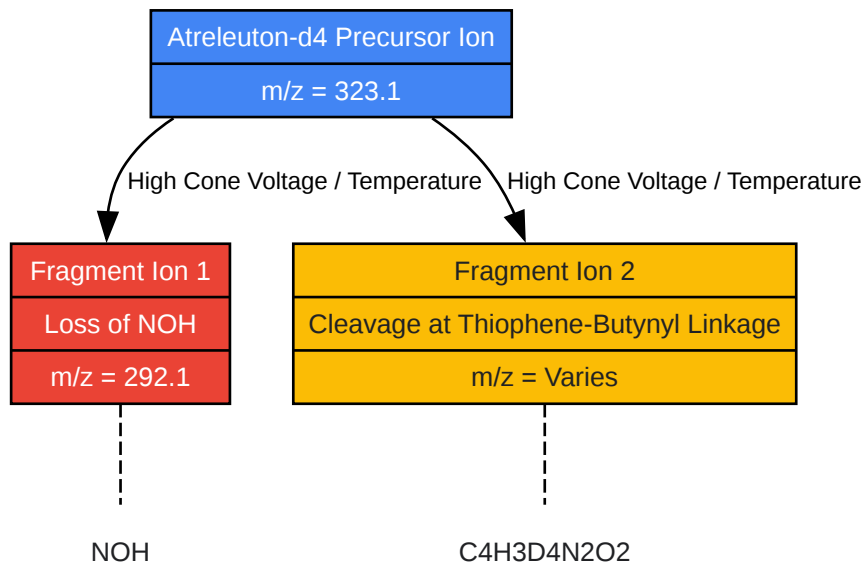

[Click to download full resolution via product page](#)

Caption: Proposed in-source fragmentation pathway for **Atreleuton-d4**.

**Need Custom Synthesis?**

BenchChem offers custom synthesis for rare earth carbides and specific isotopic labeling.

Email: [info@benchchem.com](mailto:info@benchchem.com) or [Request Quote Online](#).

## References

- 1. [researchgate.net](https://www.researchgate.net) [[researchgate.net](https://www.researchgate.net)]
- 2. [researchgate.net](https://www.researchgate.net) [[researchgate.net](https://www.researchgate.net)]
- 3. [arkat-usa.org](https://www.arkat-usa.org) [[arkat-usa.org](https://www.arkat-usa.org)]
- 4. Comprehensive Composition, Structure, and Size Characterization for Thiophene Compounds in Petroleum Using Ultrahigh-Resolution Mass Spectrometry and Trapped Ion Mobility Spectrometry - PubMed [[pubmed.ncbi.nlm.nih.gov](https://pubmed.ncbi.nlm.nih.gov)]
- To cite this document: BenchChem. [Preventing in-source fragmentation of Atreleuton-d4]. BenchChem, [2026]. [Online PDF]. Available at: [<https://www.benchchem.com/product/b12362281/docs#preventing-in-source-fragmentation-of-atreleuton-d4>]

**Disclaimer & Data Validity:**

The information provided in this document is for Research Use Only (RUO) and is strictly not intended for diagnostic or therapeutic procedures. While BenchChem strives to provide accurate protocols, we make no warranties, express or implied, regarding the fitness of this product for every specific experimental setup.

**Technical Support:** The protocols provided are for reference purposes. Unsure if this reagent suits your experiment?

**Need Industrial/Bulk Grade?** [Request Custom Synthesis Quote](#)

## BenchChem

Our mission is to be the trusted global source of essential and advanced chemicals, empowering scientists and researchers to drive progress in science and industry.

### Contact

Address: 3281 E Guasti Rd  
Ontario, CA 91761, United States  
Phone: (601) 213-4426  
Email: [info@benchchem.com](mailto:info@benchchem.com)

[Contact our Ph.D. Support Team for a compatibility check](#)