

# Endogenous Modulators of Kv7.2 Potassium Channels: An In-depth Technical Guide

**Author:** BenchChem Technical Support Team. **Date:** April 2026

## Compound of Interest

Compound Name: *Kv7.2 modulator 2*

Cat. No.: *B12362331*

[Get Quote](#)

For Researchers, Scientists, and Drug Development Professionals

This technical guide provides a comprehensive overview of the key endogenous modulators of the Kv7.2 potassium channel, a critical regulator of neuronal excitability. The content herein details the molecular mechanisms, quantitative effects, and experimental methodologies used to investigate these interactions, offering a valuable resource for researchers in neuroscience and professionals engaged in drug discovery targeting neuronal ion channels.

## Phosphatidylinositol 4,5-bisphosphate (PIP<sub>2</sub>): The Essential Cofactor

Phosphatidylinositol 4,5-bisphosphate (PIP<sub>2</sub>) is a minor anionic phospholipid of the inner plasma membrane that is indispensable for the function of Kv7.2 channels.<sup>[1][2][3][4]</sup> It is not merely a permissive factor but acts as a direct gating modulator, stabilizing the open state of the channel.<sup>[2][5]</sup> Depletion of membrane PIP<sub>2</sub> leads to a profound inhibition of Kv7.2 currents, a mechanism that underlies the modulation of these channels by various G-protein coupled receptors (GPCRs).<sup>[6][7]</sup>

## Quantitative Effects of PIP<sub>2</sub> on Kv7.2 Channel Function

Parameter	Effect of PIP2	Quantitative Value/Observation	Reference(s)
Channel Activity	Essential for channel opening	Channel activity rapidly runs down upon patch excision, rescued by exogenous PIP2 application.	[3]
Voltage-dependence	Leftward shift in the voltage-dependence of activation	Co-expression with PI(4)5-kinase increases maximal open probability.	[8]
Current Amplitude	Increases macroscopic current	Depletion of PIP2 via voltage-sensitive phosphatases reduces current amplitude.	[4]
Activation/Deactivation	Slows deactivation kinetics	Reduced PIP2 leads to faster deactivation ( $\tau_{\text{deact}}$ : $311 \pm 21$ ms in control vs. $212 \pm 12$ ms in reduced PIP2).	[5]

## Signaling Pathway: GPCR-Mediated PIP2 Depletion

A major pathway for the physiological regulation of Kv7.2 channels involves the activation of Gq/11-coupled receptors, such as the M1 muscarinic acetylcholine receptor.[5][7][9] This initiates a signaling cascade that leads to the hydrolysis of PIP2 and subsequent channel inhibition.

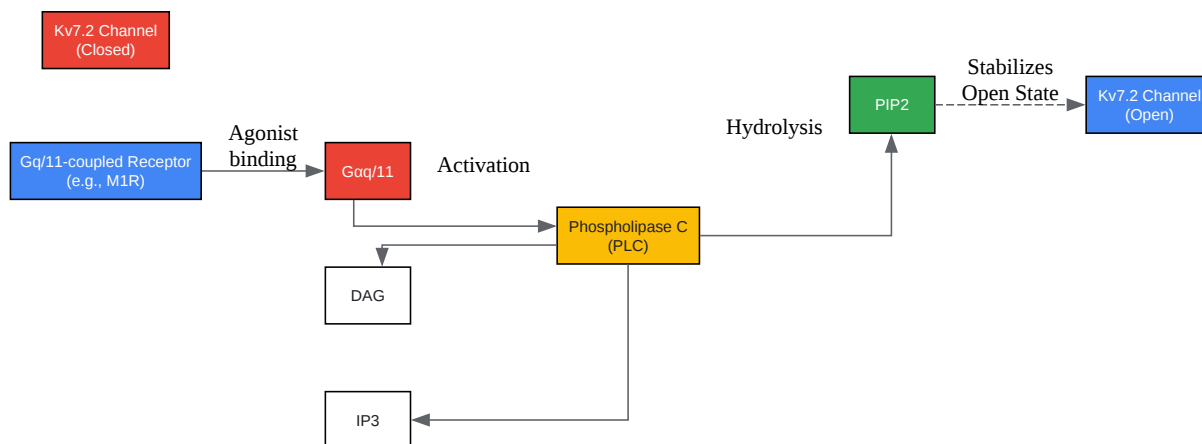

[Click to download full resolution via product page](#)

GPCR-mediated PIP2 depletion pathway.

## Experimental Protocol: Whole-Cell Patch Clamp Analysis of PIP2 Modulation

This protocol outlines the electrophysiological recording of Kv7.2 currents in a heterologous expression system to assess modulation by PIP2.[3][10]

- Cell Culture and Transfection:
  - Culture HEK293T cells in DMEM supplemented with 10% FBS and 1% penicillin-streptomycin.
  - Co-transfect cells with plasmids encoding Kv7.2 and a fluorescent marker (e.g., GFP) using a suitable transfection reagent. For PIP2 depletion experiments, co-transfect with a voltage-sensitive phosphatase (e.g., Ci-VSP).
  - Incubate for 24-48 hours post-transfection.

- Electrophysiological Recording:
  - External Solution (in mM): 140 NaCl, 4 KCl, 2 CaCl<sub>2</sub>, 1 MgCl<sub>2</sub>, 10 HEPES, 10 Glucose (pH 7.4 with NaOH).
  - Internal Solution (in mM): 125 KCl, 10 HEPES, 5 MgCl<sub>2</sub>, 5 EGTA, 5 Na<sub>2</sub>ATP (pH 7.2 with KOH).[11]
  - Pull borosilicate glass pipettes to a resistance of 2-5 MΩ when filled with internal solution.
  - Establish a whole-cell patch-clamp configuration on a transfected cell identified by fluorescence microscopy.
  - Hold the membrane potential at -80 mV.
  - To elicit Kv7.2 currents, apply depolarizing voltage steps (e.g., from -80 mV to +40 mV in 10 mV increments for 500 ms).
  - To assess PIP<sub>2</sub> dependence, activate the co-expressed voltage-sensitive phosphatase by applying a strong depolarizing prepulse (e.g., to +100 mV for 1-3 seconds) before the test pulse.
  - Record and analyze the resulting currents using appropriate software (e.g., pCLAMP).
- Data Analysis:
  - Measure the peak current amplitude at each voltage step.
  - Construct current-voltage (I-V) and conductance-voltage (G-V) relationships.
  - Fit the G-V curve with a Boltzmann function to determine the half-activation voltage (V<sub>1/2</sub>) and slope factor.
  - Compare these parameters before and after PIP<sub>2</sub> depletion to quantify the effect.

## Calmodulin (CaM): The Calcium Sensor

Calmodulin (CaM) is a ubiquitous calcium-binding protein that serves as a crucial auxiliary subunit for Kv7.2 channels.[12][13] It binds to two distinct helical regions in the C-terminus of Kv7.2, termed helix A and helix B.[12] This interaction is essential for the proper folding, assembly, and trafficking of the channel to the plasma membrane.[13] Furthermore, CaM confers calcium sensitivity to the channel, although the precise nature of this regulation is complex and isoform-dependent.

## Quantitative Effects of Calmodulin on Kv7.2 Channel Function

Parameter	Effect of Calmodulin	Quantitative Value/Observation	Reference(s)
Channel Trafficking	Essential for ER exit	Mutations that disrupt CaM binding prevent surface expression.	[12][13]
Binding Affinity	Binds to Helix A and B	Kd of Ca <sup>2+</sup> /N-lobe of CaM for Kv7.4 B-helix is 210 nM.	[10]
Calcium Sensitivity	Modulates channel activity	Ca <sup>2+</sup> -bound CaM alters channel gating, though the effect (inhibition vs. potentiation) can be complex and context-dependent.	[14]
Interaction with PIP2	Competes with PIP2 for binding	Ca <sup>2+</sup> -CaM and PIP2 competitively bind to the proximal C-terminus of Kv7 channels.	[14]

## Signaling Pathway: Crosstalk between Ca<sup>2+</sup>/CaM and PIP2

The interplay between CaM and PIP2 is a critical aspect of Kv7.2 regulation. At resting intracellular calcium levels, both CaM and PIP2 are bound to the channel. Following an increase in intracellular calcium, Ca<sup>2+</sup>-bound CaM can displace PIP2 from its binding site, leading to a modulation of channel activity.

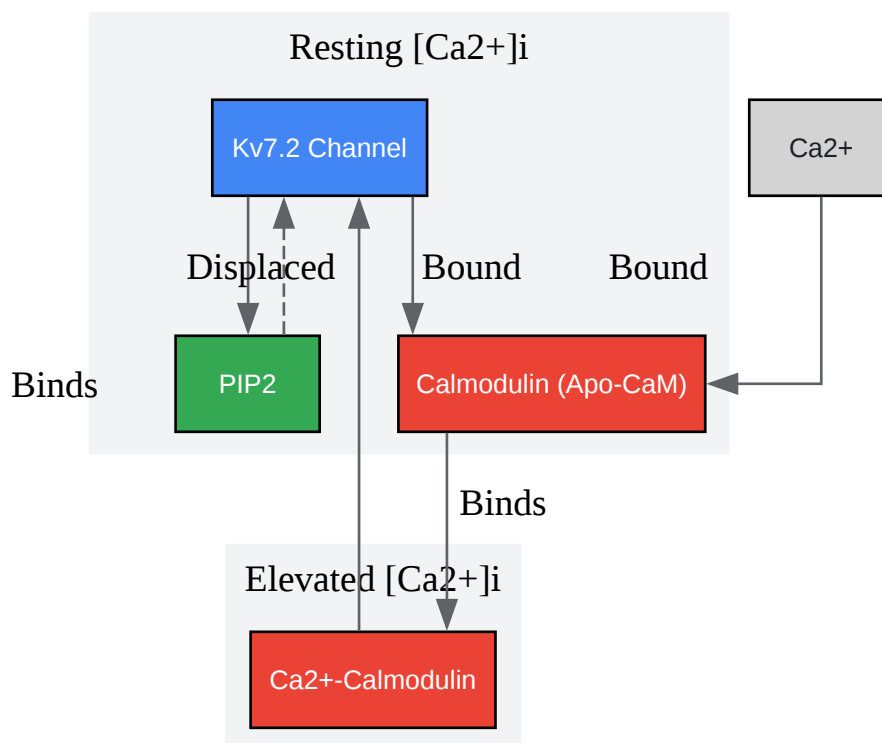

[Click to download full resolution via product page](#)

Crosstalk between Ca<sup>2+</sup>/Calmodulin and PIP2.

## Experimental Protocol: Co-Immunoprecipitation (Co-IP) of Kv7.2 and Calmodulin

This protocol describes the co-immunoprecipitation of Kv7.2 and Calmodulin from brain tissue to demonstrate their physical interaction.<sup>[15][16][17][18][19]</sup>

- Tissue Lysis:
  - Homogenize fresh or frozen brain tissue (e.g., hippocampus) in ice-cold lysis buffer (e.g., RIPA buffer) containing protease and phosphatase inhibitors.

- Centrifuge the lysate at high speed (e.g., 14,000 x g) for 15 minutes at 4°C to pellet cellular debris.
- Collect the supernatant containing the solubilized proteins.
- Immunoprecipitation:
  - Pre-clear the lysate by incubating with protein A/G agarose beads for 1 hour at 4°C.
  - Centrifuge and transfer the pre-cleared lysate to a new tube.
  - Add a primary antibody specific for Kv7.2 to the lysate and incubate overnight at 4°C with gentle rotation.
  - Add fresh protein A/G agarose beads and incubate for 2-4 hours at 4°C to capture the antibody-protein complexes.
- Washing and Elution:
  - Pellet the beads by centrifugation and discard the supernatant.
  - Wash the beads several times with ice-cold lysis buffer to remove non-specific binding proteins.
  - Elute the bound proteins from the beads by adding SDS-PAGE sample buffer and boiling for 5-10 minutes.
- Western Blot Analysis:
  - Separate the eluted proteins by SDS-PAGE.
  - Transfer the proteins to a PVDF membrane.
  - Probe the membrane with a primary antibody specific for Calmodulin.
  - Incubate with a secondary antibody conjugated to HRP and detect the signal using a chemiluminescence substrate.

- A band corresponding to the molecular weight of Calmodulin in the Kv7.2 immunoprecipitate confirms the interaction.

## Syntaxin-1A: A Link to the Exocytotic Machinery

Syntaxin-1A, a component of the SNARE complex involved in synaptic vesicle fusion, directly interacts with Kv7.2 channels.[1][20][21][22] This interaction modulates channel gating, suggesting a role for Kv7.2 in the fine-tuning of neurotransmitter release.

## Quantitative Effects of Syntaxin-1A on Kv7.2 Channel Function

Parameter	Effect of Syntaxin-1A	Quantitative Value/Observation	Reference(s)
Current Amplitude	Reduction in macroscopic conductance	~2-fold reduction in homomeric Kv7.2 channel conductance.	[21][22]
Activation Kinetics	Slower activation	~2-fold slower activation kinetics of homomeric Kv7.2 channels.	[21][22]
Voltage-dependence	No significant change	V <sub>1/2</sub> of activation is not significantly affected.	[20]

## Experimental Workflow: Investigating Syntaxin-1A Modulation of Kv7.2

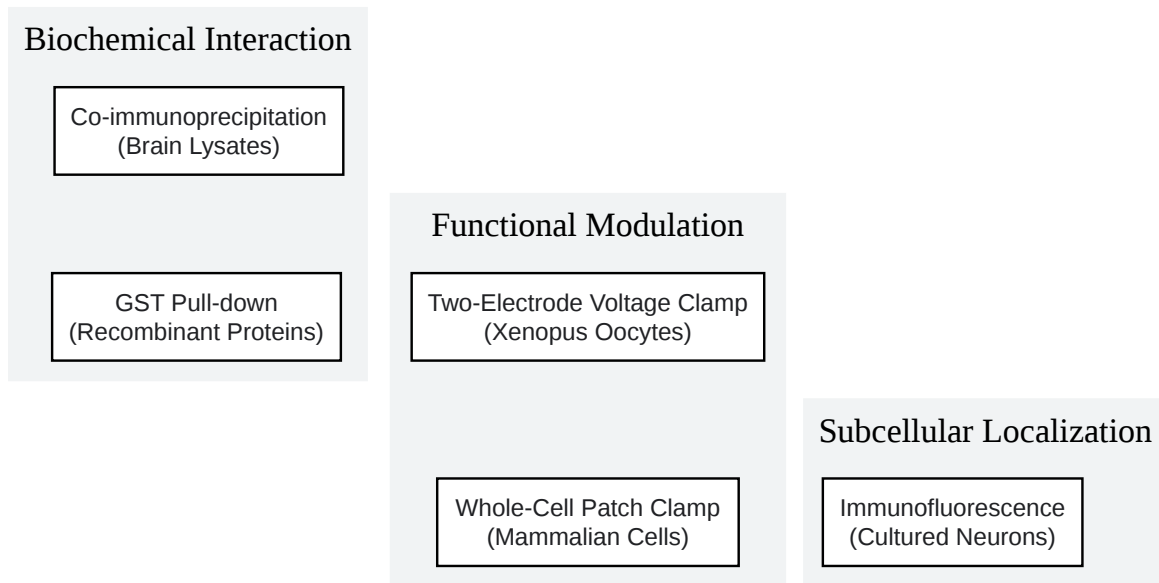

[Click to download full resolution via product page](#)

Experimental workflow for studying Syntaxin-1A and Kv7.2.

## Supramolecular Signaling Complexes: AKAPs and Ankyrin-G

The function and localization of Kv7.2 channels are tightly controlled by their incorporation into large protein complexes. A-kinase anchoring proteins (AKAPs), particularly AKAP79/150, act as signaling scaffolds that bring kinases and phosphatases into close proximity with the channel, facilitating its modulation by neurotransmitters.[12][23][24][25][26][27][28][29][30][31] Ankyrin-G is a cytoskeletal-associated protein that anchors Kv7.2 channels to the axon initial segment (AIS) and nodes of Ranvier, critical sites for action potential initiation and propagation.[11][13][32][33][34][35][36][37]

## Quantitative Effects of AKAPs and Ankyrin-G on Kv7.2

Modulator	Effect on Kv7.2	Quantitative Value/Observation	Reference(s)
AKAP79/150	Facilitates muscarinic suppression of M-current	Disruption of AKAP79/150 interaction reduces M-current suppression by oxotremorine-M from ~50% to ~26%.	[12]
Ankyrin-G	Clustering at the AIS and nodes of Ranvier	Knockout of ankyrin-G abolishes the localization of Kv7.2 at the AIS.	[33][37]

## Signaling Pathway: AKAP79/150-Mediated Modulation of Kv7.2

AKAP79/150 orchestrates a multi-protein complex that couples M1 muscarinic receptor activation to the phosphorylation and subsequent inhibition of Kv7.2 channels.

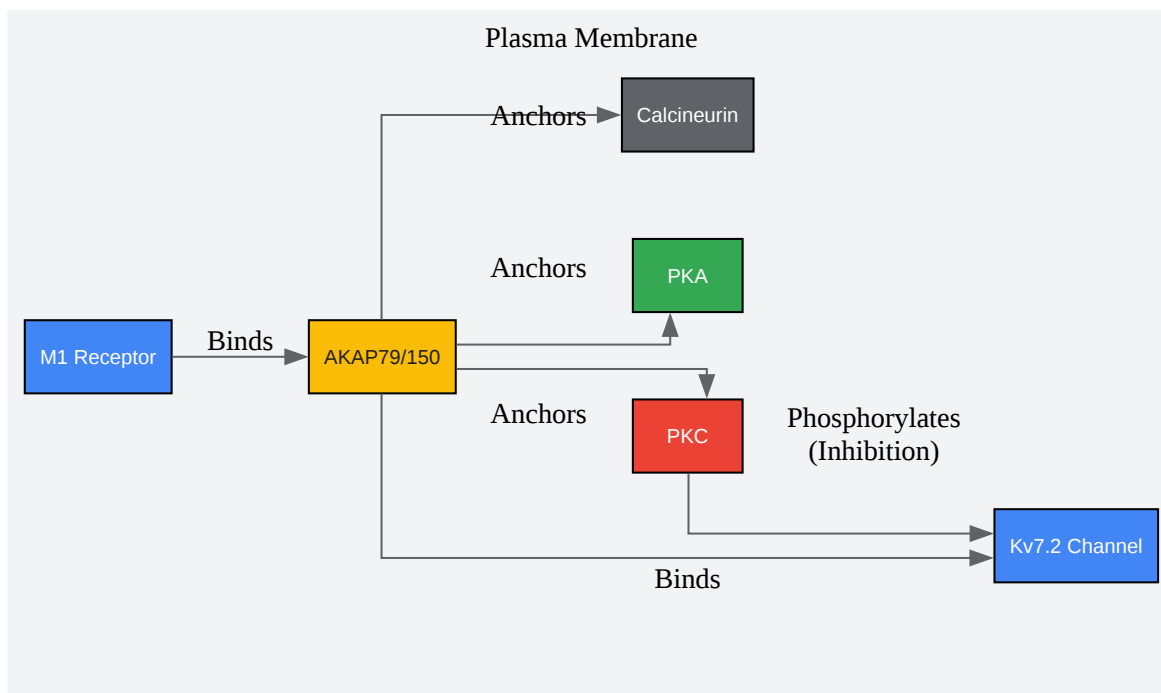

[Click to download full resolution via product page](#)

AKAP79/150 signaling complex at the Kv7.2 channel.

## Other Endogenous Lipids

Besides PIP2, other endogenous lipids have been shown to modulate the activity of Kv7.2 channels, suggesting a broader role for the lipid environment in regulating neuronal excitability.

## Quantitative Effects of Other Lipids on Kv7.2 Channel Function

Lipid Class	Specific Lipid (Example)	Effect on Kv7.2	Quantitative Value/Observation	Reference(s)
Polyunsaturated Fatty Acids (PUFAs)	Docosahexaenoic acid (DHA)	Leftward shift in V <sub>1/2</sub> of activation	Varies with specific PUFA and channel subtype.	[28]
Cholesterol	Cholesterol	Modulates current amplitude	Both depletion and enrichment of membrane cholesterol can inhibit Kv7.2/7.3 currents.	[4][38][39]

This guide provides a foundational understanding of the complex regulation of Kv7.2 channels by endogenous modulators. Further research into the intricate details of these interactions will undoubtedly pave the way for novel therapeutic strategies for a range of neurological disorders characterized by neuronal hyperexcitability.

### Need Custom Synthesis?

BenchChem offers custom synthesis for rare earth carbides and specific isotopic labeling.

Email: [info@benchchem.com](mailto:info@benchchem.com) or [Request Quote Online](#).

## References

- 1. Two-electrode voltage clamp - PubMed [[pubmed.ncbi.nlm.nih.gov](https://pubmed.ncbi.nlm.nih.gov)]
- 2. PIP2-dependent coupling of voltage sensor and pore domains in Kv7.2 channel - PMC [[pmc.ncbi.nlm.nih.gov](https://pmc.ncbi.nlm.nih.gov)]
- 3. [researchgate.net](https://www.researchgate.net) [[researchgate.net](https://www.researchgate.net)]
- 4. [scispace.com](https://www.scispace.com) [[scispace.com](https://www.scispace.com)]
- 5. [mdpi.com](https://www.mdpi.com) [[mdpi.com](https://www.mdpi.com)]

- 6. Regulation of M(Kv7.2/7.3) channels in neurons by PIP2 and products of PIP2 hydrolysis: significance for receptor-mediated inhibition - PMC [[pmc.ncbi.nlm.nih.gov](https://pubmed.ncbi.nlm.nih.gov/)]
- 7. [Frontiers | Editorial: Kv7 Channels: Structure, Physiology, and Pharmacology](https://www.frontiersin.org/) [[frontiersin.org](https://www.frontiersin.org/)]
- 8. Two-electrode Voltage-clamp Recordings in *Xenopus laevis* Oocytes: Reconstitution of Abscisic Acid Activation of SLAC1 Anion Channel via PYL9 ABA Receptor - PMC [[pmc.ncbi.nlm.nih.gov](https://pubmed.ncbi.nlm.nih.gov/)]
- 9. Regulation of neural KCNQ channels: signalling pathways, structural motifs and functional implications - PMC [[pmc.ncbi.nlm.nih.gov](https://pubmed.ncbi.nlm.nih.gov/)]
- 10. [Whole Cell Patch Clamp Protocol](https://www.protocols.io/) [[protocols.io](https://www.protocols.io/)]
- 11. [researchgate.net](https://www.researchgate.net/) [[researchgate.net](https://www.researchgate.net/)]
- 12. AKAP79/150 Signal Complexes in G-Protein Modulation of Neuronal Ion Channels - PMC [[pmc.ncbi.nlm.nih.gov](https://pubmed.ncbi.nlm.nih.gov/)]
- 13. [mdpi.com](https://www.mdpi.com/) [[mdpi.com](https://www.mdpi.com/)]
- 14. [researchgate.net](https://www.researchgate.net/) [[researchgate.net](https://www.researchgate.net/)]
- 15. Syntaxin 1A co-associates with native rat brain and cloned large conductance, calcium-activated potassium channels in situ - PMC [[pmc.ncbi.nlm.nih.gov](https://pubmed.ncbi.nlm.nih.gov/)]
- 16. [creative-diagnostics.com](https://www.creative-diagnostics.com/) [[creative-diagnostics.com](https://www.creative-diagnostics.com/)]
- 17. Co-immunoprecipitation from Brain | Springer Nature Experiments [[experiments.springernature.com](https://www.experiments.springernature.com/)]
- 18. Co-Immunoprecipitation from Brain | Springer Nature Experiments [[experiments.springernature.com](https://www.experiments.springernature.com/)]
- 19. [researchgate.net](https://www.researchgate.net/) [[researchgate.net](https://www.researchgate.net/)]
- 20. Direct Interaction of a Brain Voltage-Gated K<sup>+</sup>Channel with Syntaxin 1A: Functional Impact on Channel Gating - PMC [[pmc.ncbi.nlm.nih.gov](https://pubmed.ncbi.nlm.nih.gov/)]
- 21. Selective Interaction of Syntaxin 1A with KCNQ2: Possible Implications for Specific Modulation of Presynaptic Activity - PMC [[pmc.ncbi.nlm.nih.gov](https://pubmed.ncbi.nlm.nih.gov/)]
- 22. [cris.biu.ac.il](https://www.cris.biu.ac.il/) [[cris.biu.ac.il](https://www.cris.biu.ac.il/)]
- 23. Mechanisms and dynamics of AKAP79/150-orchestrated multi-protein signalling complexes in brain and peripheral nerve - PubMed [[pubmed.ncbi.nlm.nih.gov](https://pubmed.ncbi.nlm.nih.gov/)]
- 24. Mechanisms and dynamics of AKAP79/150-orchestrated multi-protein signalling complexes in brain and peripheral nerve - PMC [[pmc.ncbi.nlm.nih.gov](https://pubmed.ncbi.nlm.nih.gov/)]

- 25. PIP Arrays - Lipid-Protein Interaction Assay - Echelon Biosciences [[echelon-inc.com](https://echelon-inc.com)]
- 26. [researchgate.net](https://researchgate.net) [[researchgate.net](https://researchgate.net)]
- 27. AKAP150 signaling complex promotes suppression of the M-current by muscarinic agonists - PMC [[pmc.ncbi.nlm.nih.gov](https://pubmed.ncbi.nlm.nih.gov)]
- 28. AKAP79/150 Anchoring of Calcineurin Controls Neuronal L-type Ca<sup>2+</sup> Channel Activity and Nuclear Signaling - PMC [[pmc.ncbi.nlm.nih.gov](https://pubmed.ncbi.nlm.nih.gov)]
- 29. Activity-dependent Transcriptional Regulation of M-type (Kv7) K<sup>+</sup> Channels by AKAP79/150-mediated NFAT Actions - PMC [[pmc.ncbi.nlm.nih.gov](https://pubmed.ncbi.nlm.nih.gov)]
- 30. Palmitoylation of A-kinase anchoring protein 79/150 modulates its nanoscale organization, trafficking, and mobility in postsynaptic spines - PMC [[pmc.ncbi.nlm.nih.gov](https://pubmed.ncbi.nlm.nih.gov)]
- 31. Ca<sup>2+</sup>/Calmodulin Disrupts AKAP79/150 Interactions with KCNQ (M-Type) K<sup>+</sup> Channels - PMC [[pmc.ncbi.nlm.nih.gov](https://pubmed.ncbi.nlm.nih.gov)]
- 32. Made for "anchorin": Kv7.2/7.3 (KCNQ2/KCNQ3) channels and the modulation of neuronal excitability in vertebrate axons - PMC [[pmc.ncbi.nlm.nih.gov](https://pubmed.ncbi.nlm.nih.gov)]
- 33. A Common Ankyrin-G-Based Mechanism Retains KCNQ and NaV Channels at Electrically Active Domains of the Axon - PMC [[pmc.ncbi.nlm.nih.gov](https://pubmed.ncbi.nlm.nih.gov)]
- 34. Ankyrin-G and Its Binding Partners in Neurons: Orchestrating the Molecular Structure of the Axon Initial Segment [[mdpi.com](https://www.mdpi.com)]
- 35. Made for "anchorin": Kv7.2/7.3 (KCNQ2/KCNQ3) channels and the modulation of neuronal excitability in vertebrate axons - PubMed [[pubmed.ncbi.nlm.nih.gov](https://pubmed.ncbi.nlm.nih.gov)]
- 36. A Unique Ion Channel Clustering Domain on the Axon Initial Segment of Mammalian Neurons - PMC [[pmc.ncbi.nlm.nih.gov](https://pubmed.ncbi.nlm.nih.gov)]
- 37. Heteromeric Kv7.2/7.3 Channels Differentially Regulate Action Potential Initiation and Conduction in Neocortical Myelinated Axons | Journal of Neuroscience [[jneurosci.org](https://www.jneurosci.org)]
- 38. [biophys.uni-frankfurt.de](https://www.biophys.uni-frankfurt.de) [[biophys.uni-frankfurt.de](https://www.biophys.uni-frankfurt.de)]
- 39. Crosstalk between cholesterol and PIP2 in the regulation of Kv7.2/Kv7.3 channels - PubMed [[pubmed.ncbi.nlm.nih.gov](https://pubmed.ncbi.nlm.nih.gov)]
- To cite this document: BenchChem. [Endogenous Modulators of Kv7.2 Potassium Channels: An In-depth Technical Guide]. BenchChem, [2026]. [Online PDF]. Available at: [<https://www.benchchem.com/product/b12362331/docs#endogenous-modulators-of-kv7-2-potassium-channels-an-in-depth-technical-guide>]

---

**Disclaimer & Data Validity:**

The information provided in this document is for Research Use Only (RUO) and is strictly not intended for diagnostic or therapeutic procedures. While BenchChem strives to provide accurate protocols, we make no warranties, express or implied, regarding the fitness of this product for every specific experimental setup.

**Technical Support:** The protocols provided are for reference purposes. Unsure if this reagent suits your experiment?

**Need Industrial/Bulk Grade?** [Request Custom Synthesis Quote](#)

## BenchChem

Our mission is to be the trusted global source of essential and advanced chemicals, empowering scientists and researchers to drive progress in science and industry.

### Contact

Address: 3281 E Guasti Rd  
Ontario, CA 91761, United States  
Phone: (601) 213-4426  
Email: [info@benchchem.com](mailto:info@benchchem.com)

[Contact our Ph.D. Support Team for a compatibility check](#)