

Application Notes and Protocols for In Vitro Efficacy Testing of Deruxtecan ADCs

Author: BenchChem Technical Support Team. **Date:** April 2026

Compound of Interest

Compound Name: Gly-Mal-GGFG-Deruxtecan 2-hydroxypropanamide

Cat. No.: B12362643

[Get Quote](#)

This document provides detailed application notes and experimental protocols for a suite of in vitro cell-based assays designed to evaluate the efficacy of deruxtecan-based Antibody-Drug Conjugates (ADCs). These assays are essential for researchers, scientists, and drug development professionals working to characterize the mechanism of action and anti-tumor activity of this class of therapeutics.

Introduction to Deruxtecan

Trastuzumab deruxtecan (T-DXd) is an antibody-drug conjugate composed of a humanized anti-HER2 monoclonal antibody, a cleavable tetrapeptide-based linker, and a potent topoisomerase I inhibitor payload, deruxtecan (DXd).[1][2][3] Its mechanism of action begins with the antibody component binding to the HER2 receptor on tumor cells.[4] Following binding, the ADC-receptor complex is internalized, and the linker is cleaved by lysosomal enzymes such as Cathepsin B and L.[1][2][5] This releases the membrane-permeable DXd payload into the cytoplasm.[2] DXd then translocates to the nucleus, where it inhibits topoisomerase I, leading to DNA double-strand breaks and ultimately, apoptotic cell death.[2][5] A key feature of deruxtecan is its ability to induce a "bystander effect," where the released payload can diffuse

across cell membranes to kill neighboring antigen-negative tumor cells, which is particularly important in tumors with heterogeneous HER2 expression.[\[2\]](#)[\[3\]](#)[\[4\]](#)[\[6\]](#)

Mechanism of Action & Signaling Pathways

To effectively design and interpret in vitro assays, a foundational understanding of the relevant biological pathways is crucial.

Deruxtecan's Cellular Mechanism of Action

The following diagram illustrates the multi-step process by which deruxtecan exerts its cytotoxic effects.

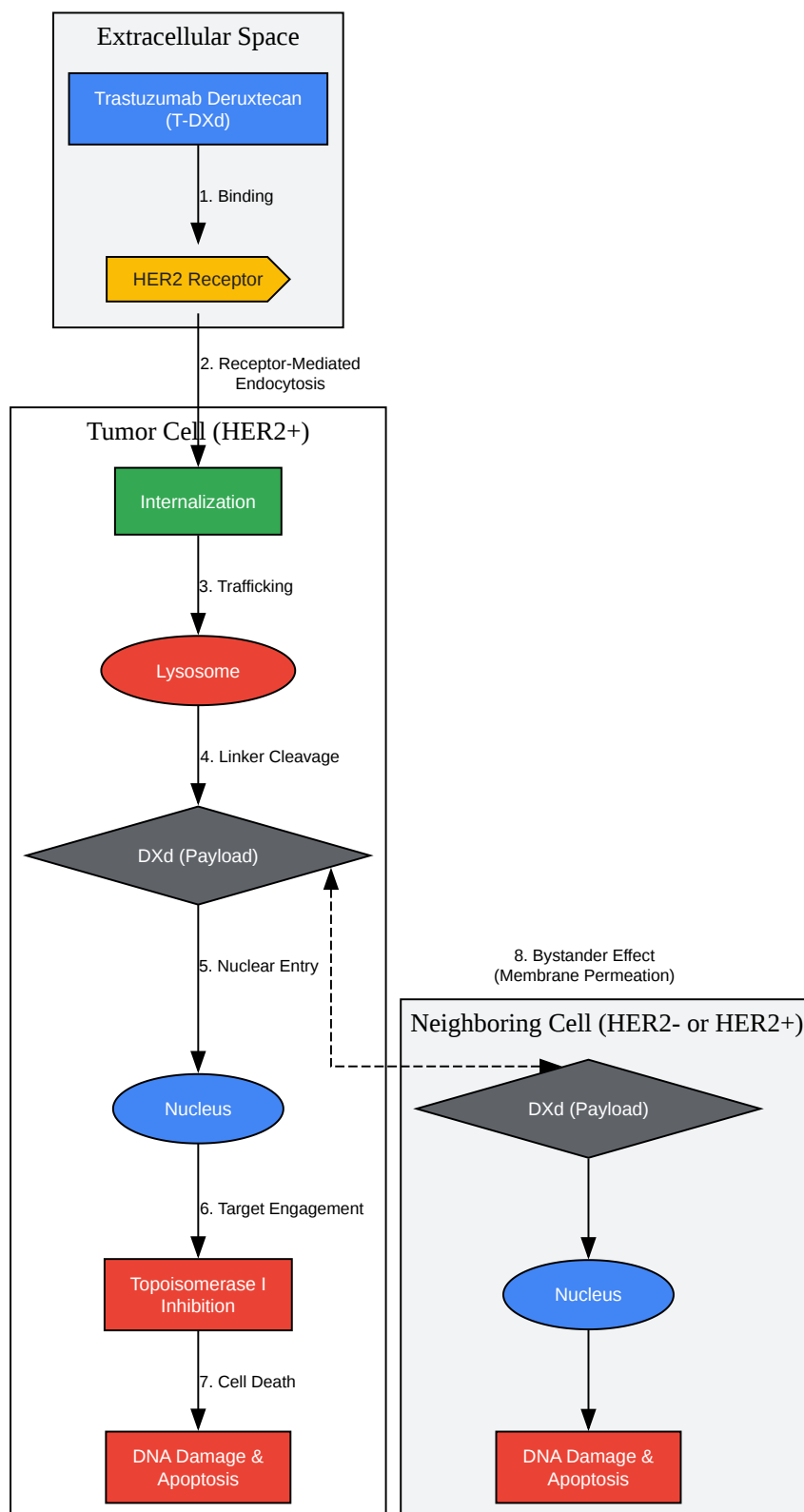

[Click to download full resolution via product page](#)

Caption: General mechanism of action for Trastuzumab Deruxtecan (T-DXd).

HER2 Signaling Pathway

The antibody component of T-DXd, trastuzumab, not only serves to deliver the payload but also has its own therapeutic effects by disrupting HER2 signaling. HER2 is a member of the ErbB family of receptor tyrosine kinases.[7] Upon dimerization, particularly with HER3, it activates potent downstream signaling cascades like PI3K/Akt and MAPK, which are critical for cell proliferation and survival.[8][9][10]

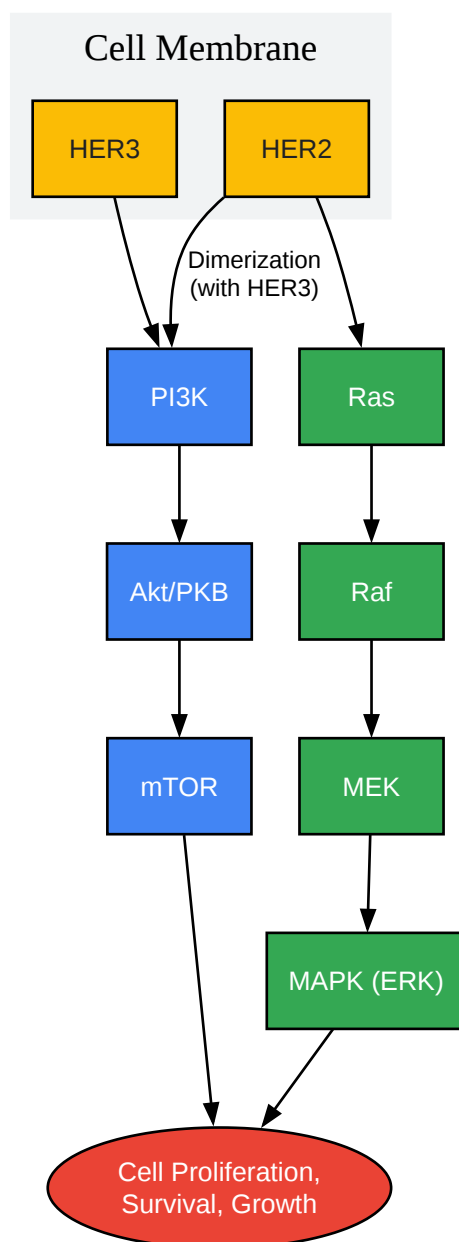

[Click to download full resolution via product page](#)

Caption: Simplified HER2 signaling cascade via PI3K/Akt and MAPK pathways.

Topoisomerase I Inhibition by DXd

The payload, DXd, is a topoisomerase I inhibitor. Topoisomerase I (Top1) relieves torsional stress in DNA during replication and transcription by creating transient single-strand breaks.[11][12] DXd stabilizes the covalent complex between Top1 and DNA (the "cleavable complex"), preventing the re-ligation of the DNA strand.[11][13] When a replication fork collides with this stabilized complex, it results in a permanent, lethal double-strand break, triggering apoptosis.[13][14]

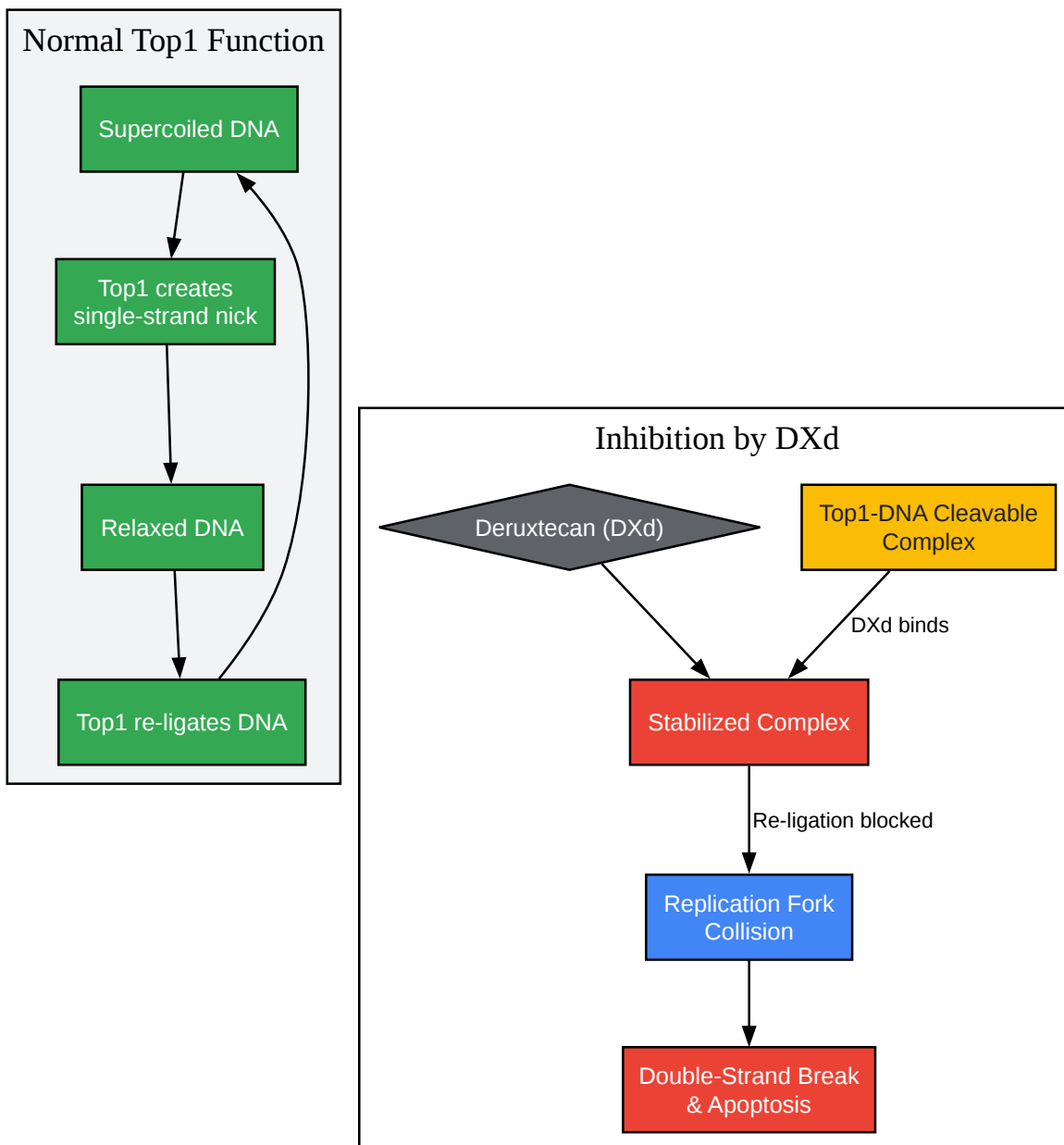

[Click to download full resolution via product page](#)

Caption: Mechanism of Topoisomerase I (Top1) inhibition by deruxtecan (DXd).

Cytotoxicity / Cell Viability Assays

Application Note

Cytotoxicity assays are fundamental for determining the dose-dependent anti-proliferative effect of deruxtecan on cancer cell lines.[15] These assays measure the concentration of the ADC required to inhibit cell growth by 50% (IC₅₀). By testing on a panel of cell lines with varying levels of HER2 expression (e.g., HER2-high, HER2-low, and HER2-negative), one can assess the target-dependent activity of the ADC.[16][17]

Experimental Workflow: Cytotoxicity Assay



[Click to download full resolution via product page](#)

Caption: General workflow for a cell viability/cytotoxicity assay.

Protocol: Flow Cytometry-Based Cytotoxicity Assay

This protocol is adapted from methods used to assess the efficacy of deruxtecan-based ADCs. [18]

- Cell Seeding: Plate cancer cells (e.g., HER2-positive SK-BR-3, HER2-low NCI-N87) in 6-well plates at a density that ensures they remain in the logarithmic growth phase throughout the experiment. Allow cells to adhere overnight.
- Treatment: Prepare serial dilutions of the deruxtecan ADC and an isotype control ADC (non-binding antibody with the same payload) in complete culture medium. Common concentration ranges are 0.1 to 50 µg/mL.[18]
- Incubation: Remove the overnight culture medium from the cells and replace it with the medium containing the ADCs. Include an "untreated" control with fresh medium only. Incubate the plates for 72 to 120 hours at 37°C in a humidified CO₂ incubator.[16][18]
- Cell Harvest: After incubation, harvest all contents of each well, including the supernatant (to collect floating, non-viable cells) and adherent cells (detached using trypsin).

- **Staining:** Centrifuge the cell suspensions, discard the supernatant, and resuspend the cell pellets in a suitable buffer like PBS. Add a viability dye such as Propidium Iodide (PI) at a final concentration of 1-2 $\mu\text{g/mL}$. PI enters cells with compromised membranes, staining non-viable cells red.
- **Flow Cytometry:** Analyze the samples on a flow cytometer. Gate on the total cell population and quantify the percentage of PI-negative (viable) cells.
- **Data Analysis:** Calculate the percentage of viable cells relative to the untreated control (set to 100% viability). Plot the percent viability against the log of the ADC concentration and use a non-linear regression model (e.g., four-parameter logistic curve) to determine the IC_{50} value.

Representative Data

Cell Line	HER2 Status	ADC	IC_{50} ($\mu\text{g/mL}$)	Citation
ARK2	TROP2 3+	Dato-DXd	0.11	[19]
ARK2	TROP2 3+	Control ADC	30.07	[19]
ARK20	TROP2 3+	Dato-DXd	0.11	[19]
ARK20	TROP2 3+	Control ADC	48.95	[19]
ARK7	TROP2 1+	Dato-DXd	80.38	[19]
ARK7	TROP2 1+	Control ADC	61.79	[19]

Note: Data shown is for Datopotamab Deruxtecan (Dato-DXd), a TROP2-targeted ADC with the same payload, illustrating the principle of target-dependent cytotoxicity.

Apoptosis Assays

Application Note

Apoptosis, or programmed cell death, is the intended mechanism of cytotoxicity for deruxtecan's payload.[2] Apoptosis assays are used to confirm and quantify that the observed cell death in cytotoxicity assays is occurring through this specific pathway. The most common method uses Annexin V, which binds to phosphatidylserine exposed on the outer leaflet of the cell membrane during early apoptosis, in combination with a viability dye like PI to distinguish between early apoptotic, late apoptotic, and necrotic cells.[16][20][21]

Protocol: Annexin V/PI Apoptosis Assay

This protocol is based on standard methodologies for detecting apoptosis.[16][21]

- **Cell Seeding and Treatment:** Seed cells in 6-well plates at a density of $3-4 \times 10^5$ cells per well.[16] The next day, treat the cells with the deruxtecan ADC at a concentration known to be effective (e.g., 1-2x the IC_{50} value or a fixed high concentration like 1,000 ng/mL).[16] Include vehicle control and isotype control ADC groups.
- **Incubation:** Incubate the cells for a period sufficient to induce apoptosis, typically 72-96 hours.[16]
- **Cell Harvest:** Collect both floating and adherent cells as described in the cytotoxicity protocol. Wash the combined cells with cold PBS.
- **Staining:** Use a commercial Annexin V-FITC Apoptosis Detection Kit. Resuspend the washed cells in 1X Binding Buffer provided in the kit. Add Annexin V-FITC and Propidium Iodide to the cell suspension.
- **Incubation:** Incubate the cells in the dark at room temperature for 15 minutes.
- **Flow Cytometry:** Analyze the stained cells by flow cytometry within one hour of staining.
 - Live cells: Annexin V-negative and PI-negative.
 - Early apoptotic cells: Annexin V-positive and PI-negative.

- Late apoptotic/necrotic cells: Annexin V-positive and PI-positive.
- Necrotic cells: Annexin V-negative and PI-positive.
- Data Analysis: Quantify the percentage of cells in each quadrant. The total apoptotic population is the sum of the early and late apoptotic cells.

Representative Data

Cell Line	Treatment (1,000 ng/mL)	% Total Apoptotic Cells (Annexin V+)	Citation
BCX.010CL	Vehicle	~5%	[16]
BCX.010CL	IgG-DXd (Control)	~8%	[16]
BCX.010CL	Dato-DXd	~35%	[16]
BCX.011CL	Vehicle	~4%	[16]
BCX.011CL	IgG-DXd (Control)	~6%	[16]
BCX.011CL	Dato-DXd	~25%	[16]

Note: Data shown is for Datopotamab Deruxtecan (Dato-DXd), illustrating the principle of apoptosis induction.

Bystander Effect Assays

Application Note

The bystander killing effect is a critical attribute of deruxtecan, enabling it to eliminate nearby tumor cells regardless of their HER2 expression status.[22][23] This is due to the high membrane permeability of the released DXd payload.[2][24] In vitro assays to measure this effect typically involve co-culturing HER2-positive and HER2-negative cells or transferring conditioned medium from ADC-treated HER2-positive cells to a culture of HER2-negative cells. [22][23]

Experimental Workflow: Bystander Assay (Co-Culture)

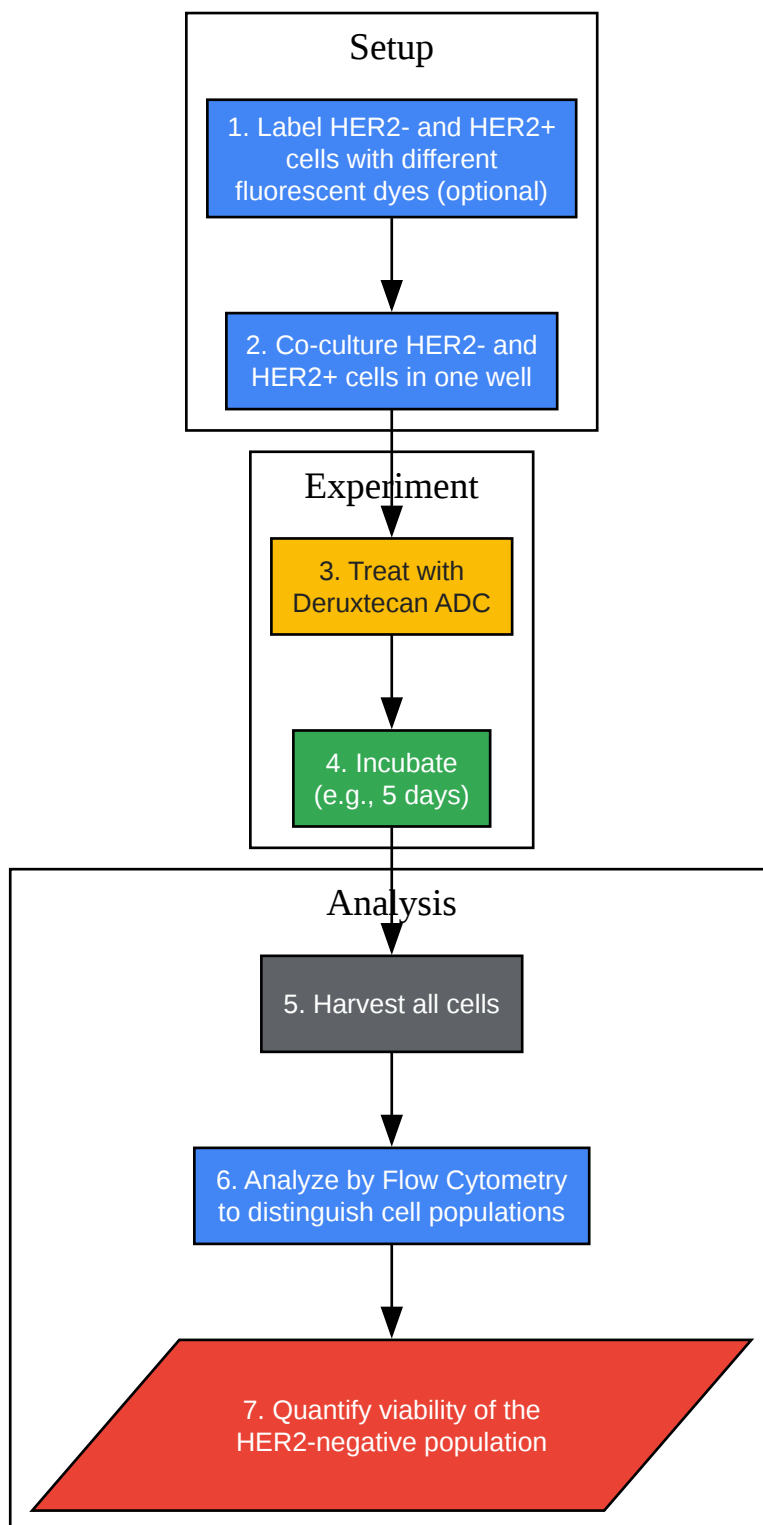

[Click to download full resolution via product page](#)

Caption: Workflow for an in vitro co-culture bystander effect assay.

Protocol: Co-Culture Bystander Killing Assay

This protocol is adapted from methodologies designed to assess the bystander effect.[\[22\]](#)[\[23\]](#)

- **Cell Preparation:** Select a HER2-positive cell line (e.g., SK-BR-3, KPL-4) and a HER2-negative cell line (e.g., MCF7, MDA-MB-468).[\[22\]](#)[\[23\]](#) To distinguish the populations during analysis, one cell line can be pre-labeled with a fluorescent tracker like CellTracker Green CMFDA, or they can be distinguished later by staining for the HER2 receptor.
- **Co-Culture Seeding:** Seed the HER2-positive and HER2-negative cells together in the same wells of a 6-well plate at a defined ratio (e.g., 1:1 or 1:3). Allow cells to adhere overnight.
- **Control Wells:** Set up control wells with each cell line cultured separately to measure the direct effect of the ADC on each population.
- **Treatment:** Treat the co-cultures and monoculture controls with the deruxtecan ADC at a concentration that is cytotoxic to the HER2-positive cells but has minimal direct effect on the HER2-negative cells (e.g., 0.1-1 $\mu\text{g}/\text{mL}$).[\[6\]](#) Include an untreated control.
- **Incubation:** Incubate the plates for an extended period, typically 5-6 days, to allow for the release of the payload and its effect on neighboring cells.[\[22\]](#)
- **Analysis:** Harvest the cells and stain for viability (e.g., with PI) and, if not pre-labeled, for HER2 expression using a fluorescently-conjugated anti-HER2 antibody.
- **Flow Cytometry:** Analyze the samples by flow cytometry. First, gate on the HER2-negative population (or the pre-labeled population). Within this gate, quantify the percentage of viable (PI-negative) cells.
- **Data Interpretation:** A significant decrease in the viability of the HER2-negative cells in the co-culture condition compared to the HER2-negative monoculture control demonstrates a bystander killing effect.

Representative Data

Condition	Treatment (0.1 µg/mL)	Viable HER2-Negative Cells (Relative #)	Citation
HCT116-Mock (HER2-) Monoculture	T-DXd	No significant change	[6]
HT-29-Mock (HER2-) Monoculture	T-DXd	No significant change	[6]
HCT116-Mock + HCT116-H2H (Co-culture)	T-DXd	Significant Reduction	[6]
HT-29-Mock + HT-29-H2H (Co-culture)	T-DXd	Significant Reduction	[6]

Note: Data is qualitative based on published findings demonstrating a significant reduction in the HER2-negative population only when co-cultured with HER2-positive cells and treated with T-DXd.

ADC Internalization Assays

Application Note

The efficacy of an ADC is critically dependent on its ability to be internalized by the target cell after binding to its surface receptor.[25] Internalization assays quantify the rate and extent to which the ADC is taken up by the cells. This can be measured using fluorescently labeled ADCs and analyzing the increase in intracellular fluorescence over time via flow cytometry or imaging.[26][27]

Protocol: Flow Cytometry-Based Internalization Assay

- **ADC Labeling:** Covalently label the deruxtecan ADC and an isotype control IgG with a stable fluorescent dye (e.g., Alexa Fluor 488) using a commercial conjugation kit, following the manufacturer's protocol.
- **Cell Preparation:** Harvest HER2-positive cells and keep them on ice to inhibit membrane trafficking.
- **Binding Step:** Incubate the cells with the fluorescently labeled ADC (e.g., 10-15 $\mu\text{g}/\text{mL}$) on ice for 30-60 minutes to allow binding to the cell surface without internalization.[\[26\]](#)
- **Washing:** Wash the cells thoroughly with cold PBS to remove any unbound ADC.
- **Internalization Induction:** Resuspend the cells in pre-warmed (37°C) culture medium and place them in a 37°C incubator. This temperature shift initiates active endocytosis.
- **Time Points:** At various time points (e.g., 0, 15, 30, 60, 120, 240 minutes), take an aliquot of the cell suspension.
- **Fluorescence Quenching:** To distinguish between surface-bound and internalized ADC, treat half of the aliquot with a quenching agent like trypan blue, which will quench the fluorescence of the surface-bound (but not the internalized) ADC. The other half remains unquenched (total fluorescence).
- **Flow Cytometry:** Analyze both quenched and unquenched samples for each time point by flow cytometry, measuring the mean fluorescence intensity (MFI).
- **Data Analysis:** The internalization rate can be calculated by plotting the MFI of the quenched samples (representing internalized ADC) over time. The internalization half-life is the time it takes for the internalized fluorescence to reach 50% of its maximum.[\[25\]](#)[\[27\]](#)

Representative Data

ADC	Cell Line	Internalization Half-Life (hours)	Citation
T-DXd	N87	~46	[27]
Trastuzumab	SKBR-3	4 - 24	[25]
FucGM1-ADC	DMS79	6.9	[25]

Note: Internalization rates are highly dependent on the cell line and antigen expression levels. Data is provided to show the range of expected outcomes.

Need Custom Synthesis?

BenchChem offers custom synthesis for rare earth carbides and specific isotopic labeling.

Email: info@benchchem.com or [Request Quote Online](#).

References

- 1. go.drugbank.com [go.drugbank.com]
- 2. Trastuzumab Deruxtecan: Changing the Destiny of HER2 Expressing Solid Tumors - PMC [pmc.ncbi.nlm.nih.gov]
- 3. discovery.researcher.life [discovery.researcher.life]
- 4. researchgate.net [researchgate.net]
- 5. Unveiling the intra-tumor fate of trastuzumab deruxtecan in a xenograft model to support its mechanism of action - PubMed [pubmed.ncbi.nlm.nih.gov]
- 6. researchgate.net [researchgate.net]
- 7. hrcak.srce.hr [hrcak.srce.hr]

- [8. A Comprehensive Review of HER2 in Cancer Biology and Therapeutics - PMC \[pmc.ncbi.nlm.nih.gov\]](#)
- [9. The oncogene HER2; Its signaling and transforming functions and its role in human cancer pathogenesis - PMC \[pmc.ncbi.nlm.nih.gov\]](#)
- [10. HER2 - Wikipedia \[en.wikipedia.org\]](#)
- [11. Topoisomerase inhibitor - Wikipedia \[en.wikipedia.org\]](#)
- [12. Topoisomerase Inhibitors - LiverTox - NCBI Bookshelf \[ncbi.nlm.nih.gov\]](#)
- [13. Mechanism of action of DNA topoisomerase inhibitors - PubMed \[pubmed.ncbi.nlm.nih.gov\]](#)
- [14. aacrjournals.org \[aacrjournals.org\]](#)
- [15. marinbio.com \[marinbio.com\]](#)
- [16. Antitumor Activity and Biomarker Analysis for TROP2 Antibody–Drug Conjugate Datopotamab Deruxtecan in Patient-Derived Breast Cancer Xenograft Models - PMC \[pmc.ncbi.nlm.nih.gov\]](#)
- [17. researchgate.net \[researchgate.net\]](#)
- [18. aacrjournals.org \[aacrjournals.org\]](#)
- [19. researchgate.net \[researchgate.net\]](#)
- [20. In Vivo and In Vitro Efficacy of Trastuzumab Deruxtecan in Uterine Serous Carcinoma - PubMed \[pubmed.ncbi.nlm.nih.gov\]](#)
- [21. Apoptosis Assay Protocol | Technical Note 244 \[denovix.com\]](#)
- [22. Bystander killing effect of DS-8201a, a novel anti-human epidermal growth factor receptor 2 antibody–drug conjugate, in tumors with human epidermal growth factor receptor 2 heterogeneity - PMC \[pmc.ncbi.nlm.nih.gov\]](#)
- [23. agilent.com \[agilent.com\]](#)
- [24. researchgate.net \[researchgate.net\]](#)
- [25. researchgate.net \[researchgate.net\]](#)
- [26. datasourcebydaiichisankyo.com \[datasourcebydaiichisankyo.com\]](#)
- [27. Quantitative evaluation of trastuzumab deruxtecan pharmacokinetics and pharmacodynamics in mouse models of varying degrees of HER2 expression - PMC \[pmc.ncbi.nlm.nih.gov\]](#)
- [To cite this document: BenchChem. \[Application Notes and Protocols for In Vitro Efficacy Testing of Deruxtecan ADCs\]. BenchChem, \[2026\]. \[Online PDF\]. Available at:](#)

[\[https://www.benchchem.com/product/b12362643/docs#application-notes-and-protocols-for-in-vitro-efficacy-testing-of-deruxtecan-adcs\]](https://www.benchchem.com/product/b12362643/docs#application-notes-and-protocols-for-in-vitro-efficacy-testing-of-deruxtecan-adcs)

Disclaimer & Data Validity:

The information provided in this document is for Research Use Only (RUO) and is strictly not intended for diagnostic or therapeutic procedures. While BenchChem strives to provide accurate protocols, we make no warranties, express or implied, regarding the fitness of this product for every specific experimental setup.

Technical Support: The protocols provided are for reference purposes. Unsure if this reagent suits your experiment?

Need Industrial/Bulk Grade? [Request Custom Synthesis Quote](#)

BenchChem

Our mission is to be the trusted global source of essential and advanced chemicals, empowering scientists and researchers to drive progress in science and industry.

Contact

Address: 3281 E Guasti Rd
Ontario, CA 91761, United States
Phone: (601) 213-4426
Email: info@benchchem.com

[Contact our Ph.D. Support Team for a compatibility check](#)