

# An In-depth Technical Guide to PID-9 Target Identification and Validation

**Author:** BenchChem Technical Support Team. **Date:** April 2026

## Compound of Interest

Compound Name: PID-9  
Cat. No.: B12362773

[Get Quote](#)

A Note on Target Nomenclature: The designation "**PID-9**" is not a standardized identifier for a single biological target. Its interpretation can vary depending on the research or organizational context. This guide addresses the most plausible candidates based on current scientific literature that could be referred to as "**PID-9**":

- Dipeptidyl Peptidase 9 (DPP9): A serine protease with diverse roles in cell signaling, immunology, and cancer.
- Proprotein Convertase Subtilisin/Kexin Type 9 (PCSK9): A crucial regulator of cholesterol homeostasis and a validated drug target.
- Interleukin-9 (IL-9): A cytokine involved in the immune response, particularly in allergic inflammation.

This document will provide an in-depth focus on Dipeptidyl Peptidase 9 (DPP9) as a multifaceted target and will also offer concise overviews of PCSK9 and IL-9.

## Part 1: Dipeptidyl Peptidase 9 (DPP9) as a Therapeutic Target

## Introduction to DPP9

Dipeptidyl Peptidase 9 (DPP9) is a member of the S9B family of serine proteases, which are characterized by their ability to cleave Xaa-Pro dipeptides from the N-terminus of proteins.[1] Unlike its well-studied relative DPP4, DPP9 is an intracellular protein.[1] Emerging research has implicated DPP9 in a variety of cellular processes, including cell proliferation, apoptosis, migration, and immune regulation.[2][3] Its diverse functions make it a compelling, albeit complex, target for therapeutic intervention in oncology and inflammatory diseases.

## DPP9 Signaling Pathways

DPP9 exerts its influence through multiple signaling pathways, often through protein-protein interactions and enzymatic activity.

### 1.2.1. Regulation of the EGFR/PI3K/Akt Signaling Pathway

DPP9 has been shown to modulate the epidermal growth factor receptor (EGFR) signaling cascade. Specifically, DPP9 can associate with H-Ras, a key upstream regulator of the Phosphatidylinositol 3-kinase (PI3K)/Akt pathway.[4] Overexpression of DPP9 has been observed to inhibit EGF-mediated Akt activation, leading to decreased cell survival and proliferation.[4] This effect is dependent on the enzymatic activity of DPP9.[4]

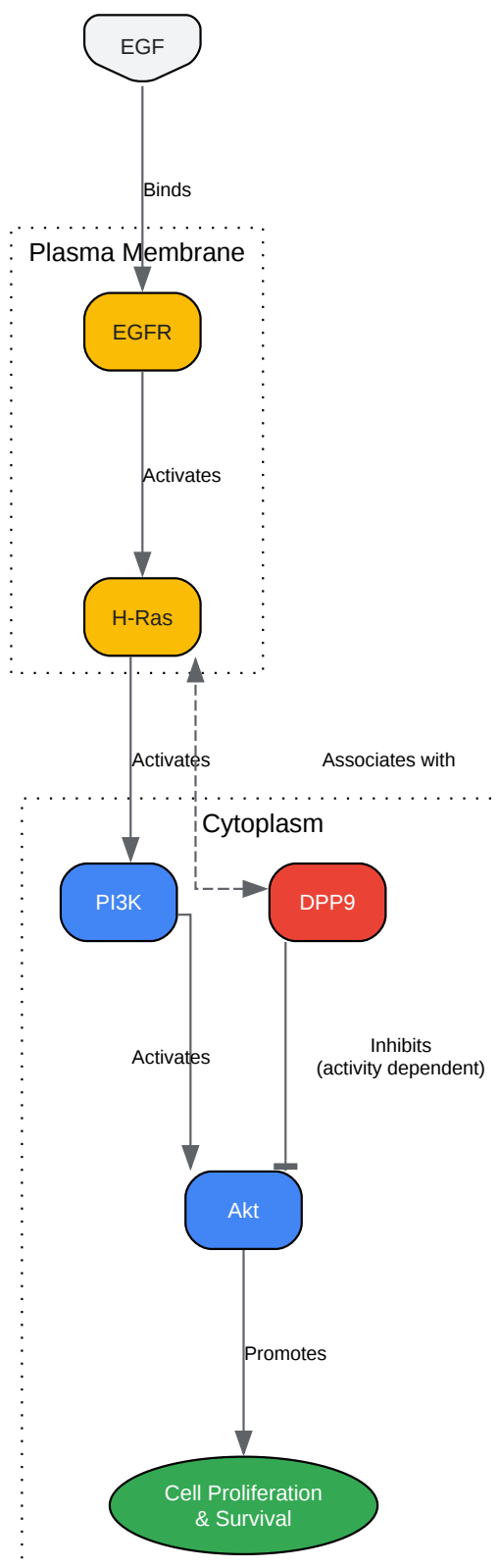

[Click to download full resolution via product page](#)

**Figure 1:** DPP9 modulation of the EGFR/PI3K/Akt pathway.

### 1.2.2. Regulation of Syk Signaling and the N-end Rule Pathway

DPP9 is a negative regulator of Spleen Tyrosine Kinase (Syk), a central kinase in B-cell receptor (BCR) signaling.[5] DPP9, recruited to Syk by Filamin A (FLNA), cleaves the N-terminus of Syk.[5][6] This processing is a prerequisite for Syk ubiquitination by the E3 ligase Cbl, leading to its degradation via the N-end rule pathway.[5] Inhibition of DPP9 stabilizes Syk, thereby prolonging its signaling output.[5]

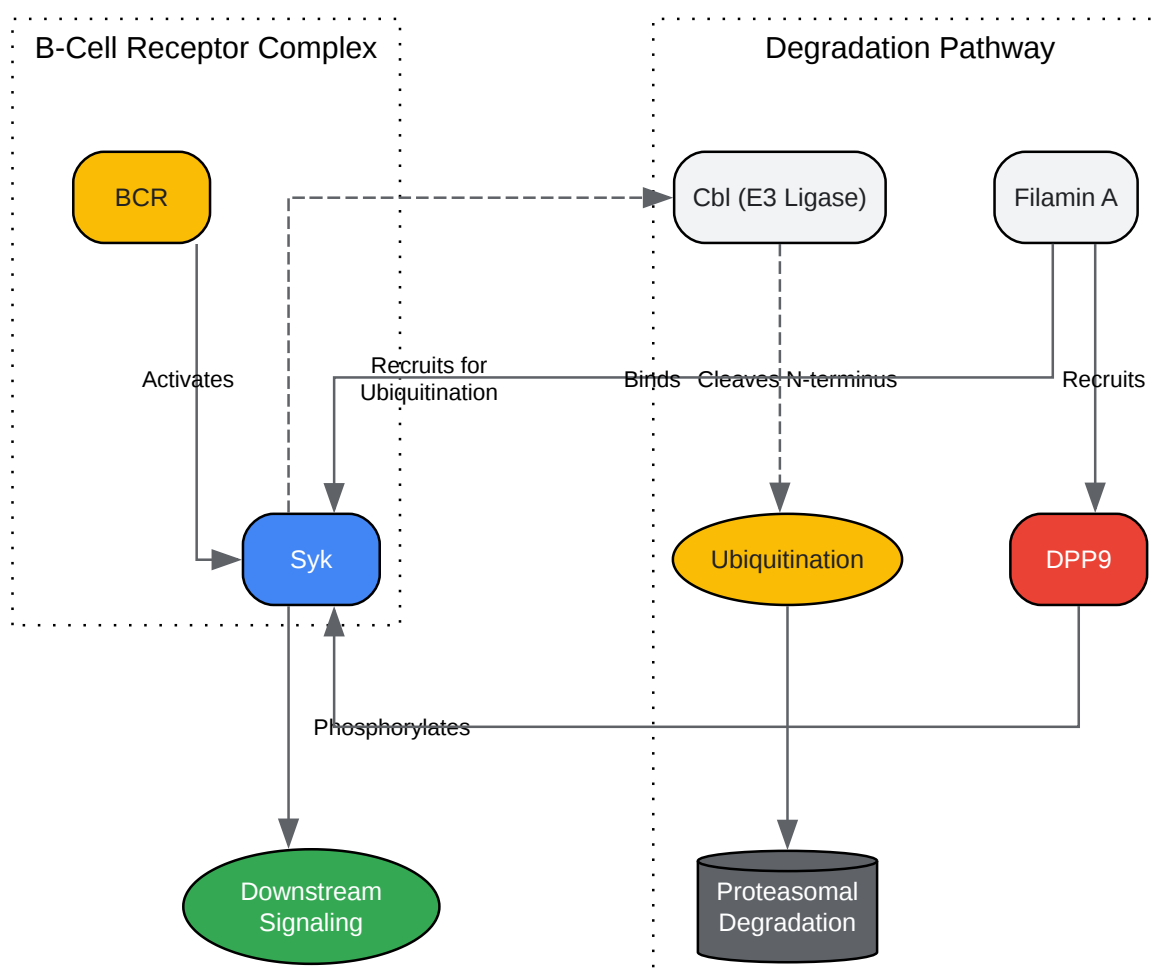

[Click to download full resolution via product page](#)

**Figure 2:** DPP9-mediated regulation of Syk degradation.

### 1.2.3. Regulation of the NLRP1 and CARD8 Inflammasomes

DPP9 acts as a key inhibitor of pyroptosis, a form of inflammatory cell death, by regulating the NLRP1 and CARD8 inflammasomes.[1][7][8] In resting cells, DPP9 sequesters the C-terminal fragments of NLRP1 and CARD8, preventing their oligomerization and the subsequent activation of caspase-1.[7][8] Inhibition of DPP9's enzymatic activity leads to the release of these fragments, triggering inflammasome assembly and pyroptosis.[2][8]

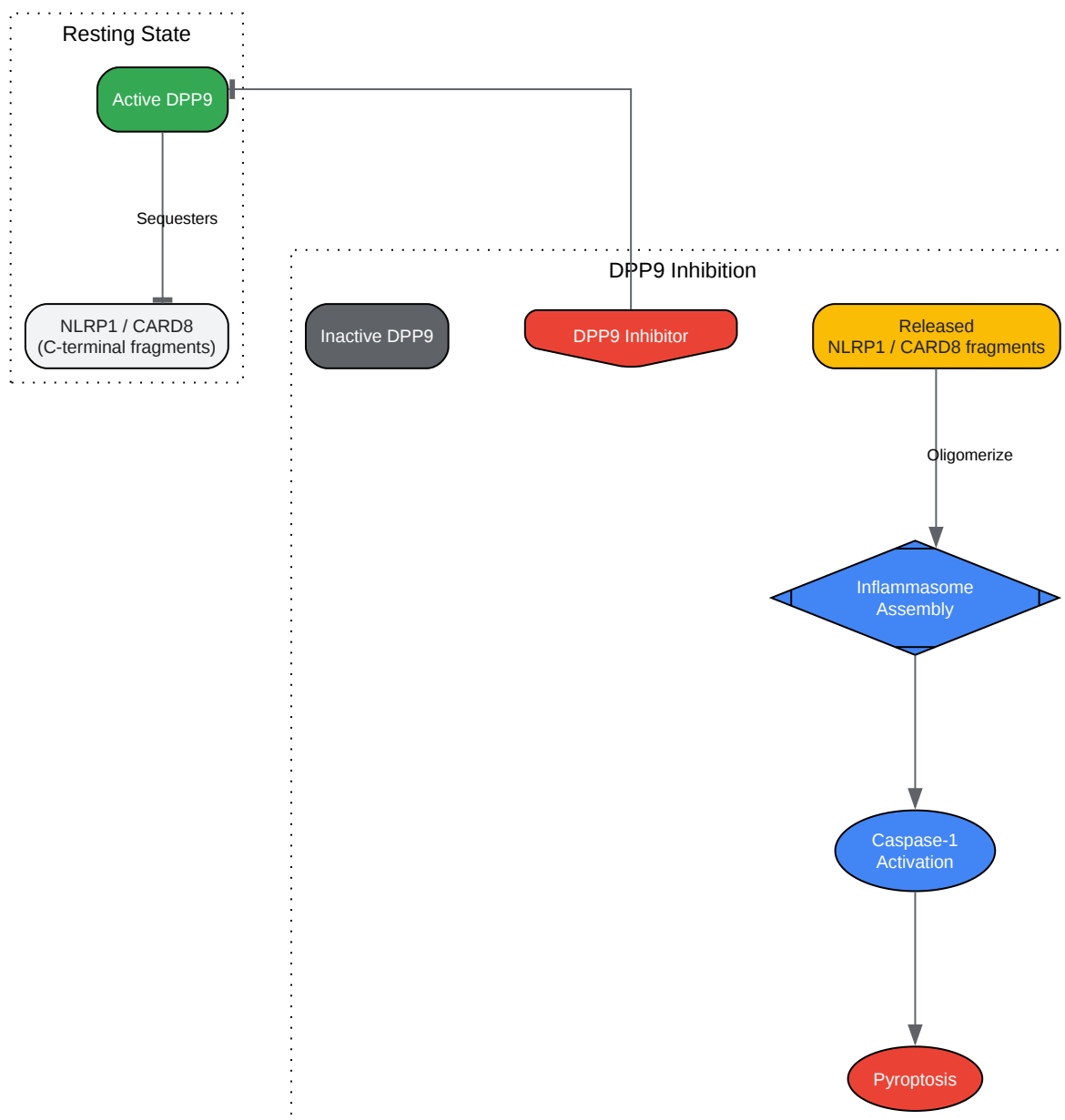

[Click to download full resolution via product page](#)

**Figure 3:** DPP9 as a negative regulator of inflammasome activation.

## Role of DPP9 in Disease

The diverse signaling roles of DPP9 implicate it in several pathologies:

- **Cancer:** DPP9 expression is altered in various cancers, including non-small cell lung cancer, colorectal cancer, and hepatocellular carcinoma.[2][9] Its role appears to be context-dependent, sometimes promoting and sometimes suppressing tumor growth.[2][3] For instance, by regulating BRCA2, a tumor suppressor involved in DNA repair, DPP9 can influence tumor development.[10] Inhibition of DPP9 is being explored to enhance the efficacy of DNA-damaging cancer therapies.[10]
- **Inflammatory Diseases:** Through its regulation of the NLRP1 and CARD8 inflammasomes, DPP9 is a critical player in inflammatory responses.[8] Dysregulation of DPP9 activity could contribute to chronic inflammatory conditions.[8]

## DPP9 Target Identification and Validation

### 1.4.1. Quantitative Data Summary

Parameter	Value	Cell/System	Reference
Enzyme Kinetics			
DPP9 S729A Mutant	Reduced enzymatic activity	MEFs and neonatal livers	[11]
Inhibitor Affinity			
Compound 42 (IC50)	3.4 nM	In vitro assay	[12]
Compound 42 Selectivity	176-fold over DPP8	In vitro assay	[12]
4-oxo- $\beta$ -lactams	Nanomolar inhibitors	In vitro assay	[13]

### 1.4.2. Experimental Protocols for Target Validation

Protocol 1: Co-Immunoprecipitation to Validate Protein-Protein Interactions (e.g., DPP9 and Syk)

- Cell Lysis: Lyse B-cells (e.g., Ramos cells) with a non-denaturing lysis buffer containing protease and phosphatase inhibitors.
- Pre-clearing: Incubate the cell lysate with Protein A/G agarose beads to reduce non-specific binding.
- Immunoprecipitation: Incubate the pre-cleared lysate with an anti-DPP9 antibody or an isotype control IgG overnight at 4°C.
- Immune Complex Capture: Add Protein A/G agarose beads to capture the antibody-protein complexes.
- Washing: Wash the beads extensively to remove non-specifically bound proteins.
- Elution: Elute the bound proteins from the beads using a low-pH elution buffer or by boiling in SDS-PAGE sample buffer.
- Western Blotting: Separate the eluted proteins by SDS-PAGE, transfer to a PVDF membrane, and probe with an anti-Syk antibody to detect the co-immunoprecipitated protein.

#### Protocol 2: In Vitro Enzymatic Assay for DPP9 Activity

- Reagents: Recombinant human DPP9, fluorogenic substrate (e.g., H-Gly-Pro-AMC), assay buffer (e.g., Tris-HCl, pH 7.5), and test inhibitors.
- Assay Setup: In a 96-well plate, add recombinant DPP9 to the assay buffer.
- Inhibitor Addition: Add varying concentrations of the test compound or vehicle control (DMSO) and incubate for a pre-determined time.
- Substrate Addition: Initiate the reaction by adding the fluorogenic substrate.
- Signal Detection: Measure the fluorescence intensity over time using a plate reader (Excitation/Emission ~360/460 nm for AMC).
- Data Analysis: Calculate the initial reaction velocity ( $V_0$ ) for each inhibitor concentration. Plot  $V_0$  against inhibitor concentration and fit the data to a suitable model to determine the IC50 value.

## Protocol 3: Cellular Thermal Shift Assay (CETSA) for Target Engagement

- Cell Treatment: Treat intact cells with the test compound or vehicle control.
- Heating: Heat the cell suspensions at a range of temperatures.
- Cell Lysis: Lyse the cells by freeze-thaw cycles.
- Fractionation: Separate the soluble fraction (containing unbound, stable protein) from the precipitated fraction by centrifugation.
- Protein Detection: Analyze the amount of soluble DPP9 in each sample by Western blotting.
- Data Analysis: A stabilizing compound will result in more soluble DPP9 at higher temperatures compared to the vehicle control, indicating target engagement.

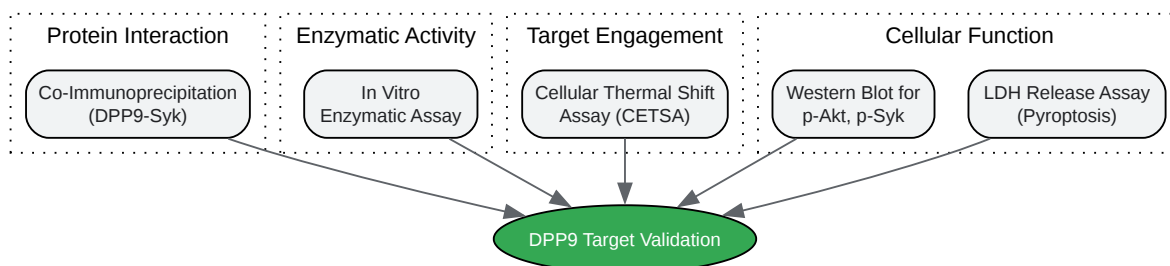

[Click to download full resolution via product page](#)

**Figure 4:** Experimental workflow for DPP9 target validation.

## Part 2: Proprotein Convertase Subtilisin/Kexin Type 9 (PCSK9)

### Overview of PCSK9

PCSK9 is a serine protease that plays a critical role in regulating low-density lipoprotein cholesterol (LDL-C) levels.<sup>[14][15]</sup> It is primarily synthesized and secreted by the liver.<sup>[16]</sup> PCSK9 binds to the LDL receptor (LDLR) on the surface of hepatocytes, and this complex is then internalized and targeted for lysosomal degradation.<sup>[14][17]</sup> This prevents the LDLR from

recycling back to the cell surface, leading to a reduced capacity of the liver to clear LDL-C from the circulation.[14]

## PCSK9 Signaling Pathway

The "signaling" of PCSK9 is more accurately described as a trafficking pathway that leads to receptor degradation.

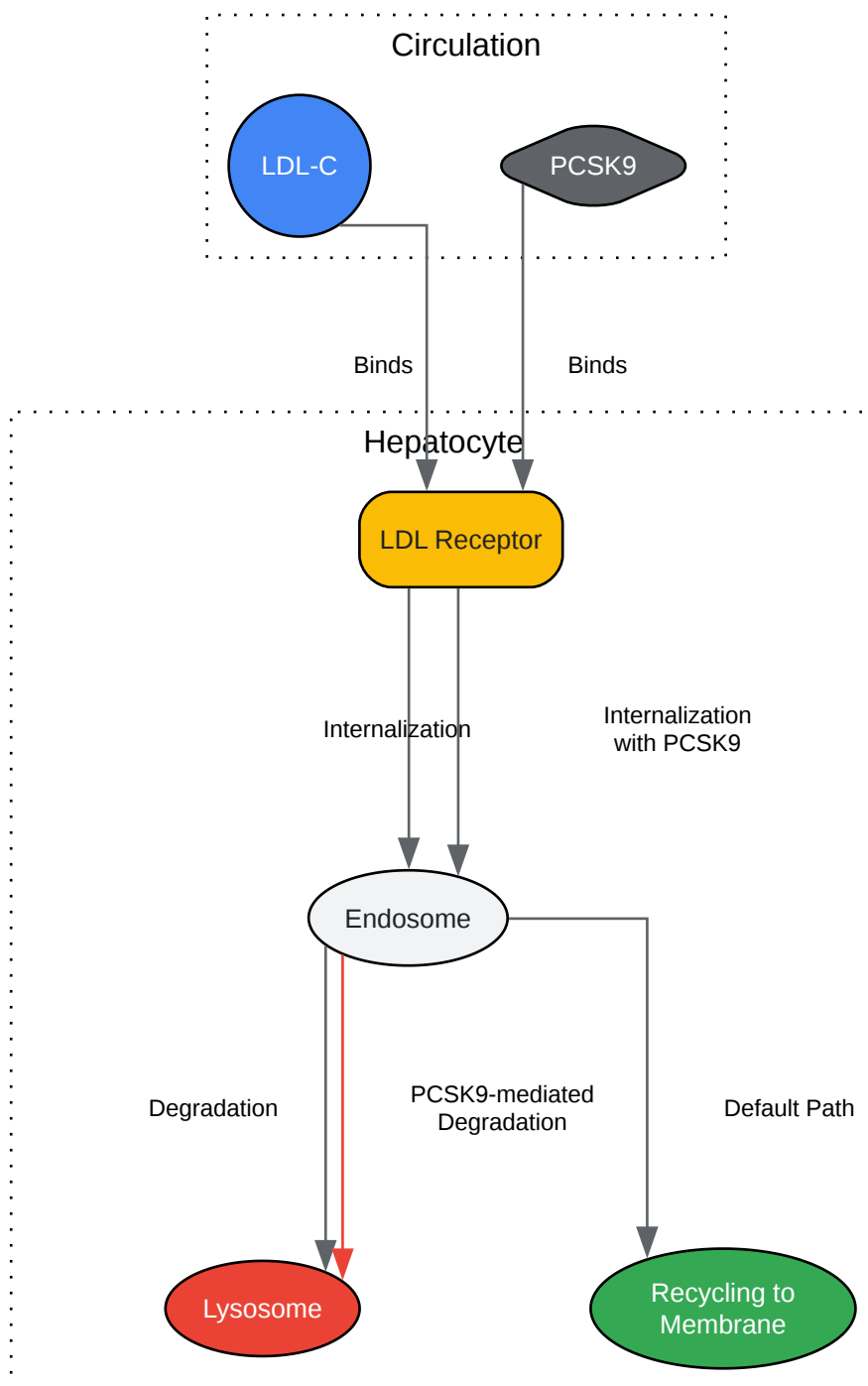

[Click to download full resolution via product page](#)

**Figure 5:** PCSK9-mediated degradation of the LDL receptor.

## PCSK9 Target Validation

PCSK9 is a clinically validated drug target. Loss-of-function mutations in the PCSK9 gene are associated with low LDL-C levels and a reduced risk of cardiovascular disease.[18]

### 2.3.1. Quantitative Data Summary

Parameter	Value	Context	Reference
LDL-C Reduction	50-70%	With monoclonal antibody inhibitors	[18][19]
Cardiovascular Risk	88% relative risk reduction	With loss-of-function mutations	[18]

### 2.3.2. Key Validation Experiments

- Genetic Studies: Association studies in human populations linking PCSK9 mutations to LDL-C levels and cardiovascular outcomes.
- Animal Models: PCSK9 knockout mice show increased hepatic LDLR expression and lower plasma cholesterol.[19]
- Clinical Trials: Large-scale clinical trials with monoclonal antibodies (e.g., evolocumab, alirocumab) demonstrating significant LDL-C lowering and reduction in cardiovascular events.[18][19]

## Part 3: Interleukin-9 (IL-9)

### Overview of IL-9

Interleukin-9 (IL-9) is a pleiotropic cytokine produced by various immune cells, including a distinct subset of T helper cells known as Th9 cells.[20][21] It plays a significant role in the pathogenesis of allergic inflammation, particularly in asthma.[22][23]

### IL-9 Signaling Pathway

IL-9 signals through a receptor complex composed of the IL-9 receptor alpha (IL-9R $\alpha$ ) and the common gamma chain ( $\gamma$ c).[20][24] This initiates downstream signaling through three major pathways: JAK/STAT, PI3K/Akt, and MAPK.[20][22]

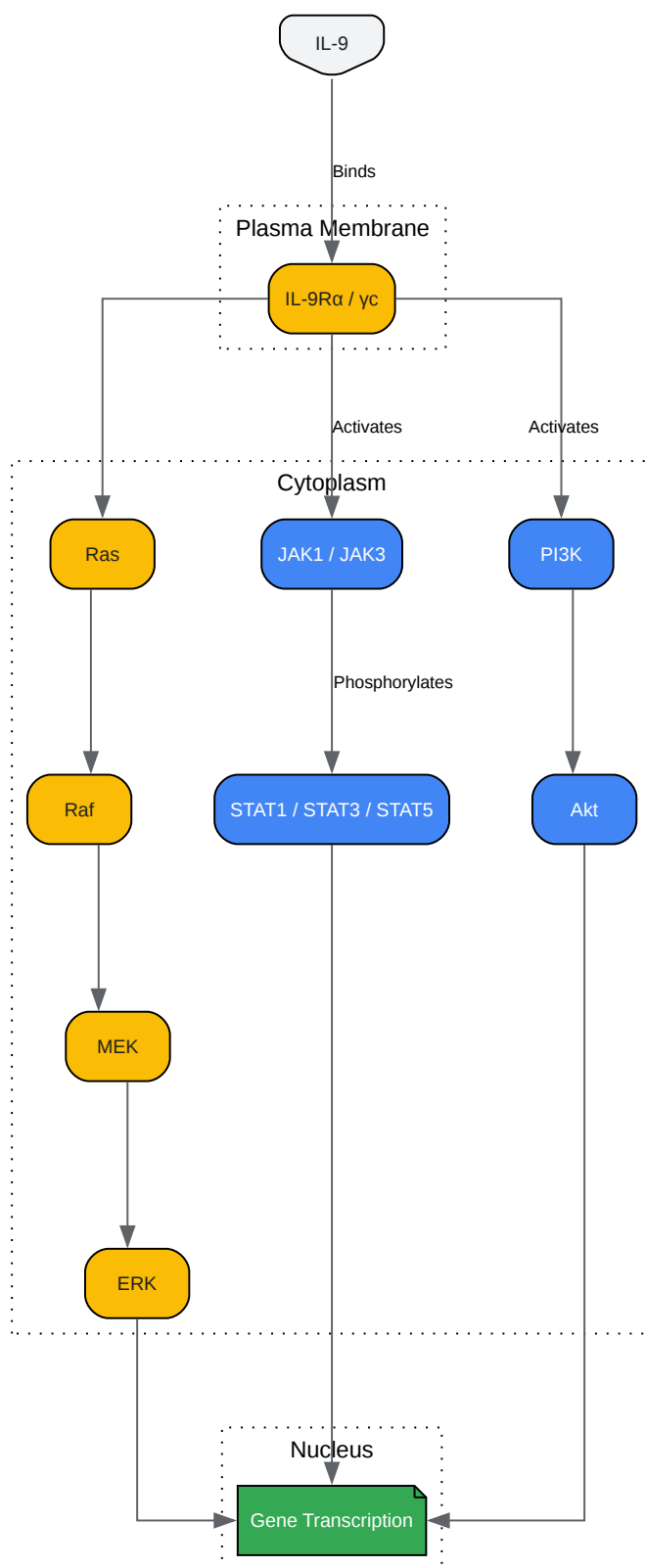

[Click to download full resolution via product page](#)

**Figure 6:** Major signaling pathways activated by IL-9.

## IL-9 as a Therapeutic Target

Elevated levels of IL-9 are found in the airways of asthmatic patients, and animal models have shown that blocking IL-9 can alleviate asthma symptoms.[22][23] This makes IL-9 a potential therapeutic target for allergic and inflammatory diseases.

### 3.3.1. Quantitative Data Summary

Parameter	Value	Context	Reference
IL-9 Receptor Affinity (Kd)	~100 pM	For IL-9	[20][24]
IL-9 mRNA Expression	Significantly higher in CLL patients	Compared to healthy controls	[25]
Serum IL-9 Levels	Significantly higher in CLL patients	Compared to healthy controls	[25]

### 3.3.2. Key Validation Experiments

- Expression Analysis: Measuring IL-9 levels (mRNA and protein) in patient samples from relevant diseases (e.g., bronchoalveolar lavage fluid in asthma).[22]
- Animal Models: Using IL-9 transgenic or knockout mice, or administering neutralizing anti-IL-9 antibodies in disease models (e.g., ovalbumin-induced asthma).[22]
- Cell-based Assays: Stimulating immune cells (e.g., mast cells, T cells) with IL-9 and measuring downstream effects like proliferation, cytokine release, and signaling pathway activation (e.g., STAT phosphorylation).

#### *Need Custom Synthesis?*

BenchChem offers custom synthesis for rare earth carbides and specific isotopic labeling.

Email: [info@benchchem.com](mailto:info@benchchem.com) or [Request Quote Online](#).

## References

- [1. DPP9 - Wikipedia \[en.wikipedia.org\]](#)
- [2. New insights into the role of dipeptidyl peptidase 8 and dipeptidyl peptidase 9 and their inhibitors - PMC \[pmc.ncbi.nlm.nih.gov\]](#)
- [3. Frontiers | New insights into the role of dipeptidyl peptidase 8 and dipeptidyl peptidase 9 and their inhibitors \[frontiersin.org\]](#)
- [4. A novel role of dipeptidyl peptidase 9 in epidermal growth factor signaling - PubMed \[pubmed.ncbi.nlm.nih.gov\]](#)
- [5. DPP9 is a novel component of the N-end rule pathway targeting the tyrosine kinase Syk | eLife \[elifesciences.org\]](#)
- [6. DPP9 is a novel component of the N-end rule pathway targeting the tyrosine kinase Syk - PMC \[pmc.ncbi.nlm.nih.gov\]](#)
- [7. uniprot.org \[uniprot.org\]](#)
- [8. The multifunctional regulatory post-proline protease dipeptidyl peptidase 9 and its inhibitors: new opportunities for therapeutics - PMC \[pmc.ncbi.nlm.nih.gov\]](#)
- [9. mdpi.com \[mdpi.com\]](#)
- [10. centenary.org.au \[centenary.org.au\]](#)
- [11. Targeted Inactivation of Dipeptidyl Peptidase 9 Enzymatic Activity Causes Mouse Neonate Lethality - PMC \[pmc.ncbi.nlm.nih.gov\]](#)
- [12. researchgate.net \[researchgate.net\]](#)
- [13. Chemoproteomics-Enabled Identification of 4-Oxo- \$\beta\$ -Lactams as Inhibitors of Dipeptidyl Peptidases 8 and 9 - PMC \[pmc.ncbi.nlm.nih.gov\]](#)
- [14. PCSK9: A Key Target for the Treatment of Cardiovascular Disease \(CVD\) - PMC \[pmc.ncbi.nlm.nih.gov\]](#)
- [15. longdom.org \[longdom.org\]](#)
- [16. Proprotein Convertase Subtilisin/Kexin Type 9 \(PCSK9\): The Multifaceted Biology, Diseases, and Pharmaceutical Interventions - PMC \[pmc.ncbi.nlm.nih.gov\]](#)
- [17. ahajournals.org \[ahajournals.org\]](#)
- [18. The PCSK9 Inhibitors: A Novel Therapeutic Target Enters Clinical Practice - PMC \[pmc.ncbi.nlm.nih.gov\]](#)
- [19. PCSK9: From Discovery and Validation to Therapy - American College of Cardiology \[acc.org\]](#)
- [20. mdpi.com \[mdpi.com\]](#)

- [21. IL-9 Signaling and its Effects in Immune Cell Types: R&D Systems \[rndsystems.com\]](#)
- [22. From bench to bedside: Therapeutic potential of interleukin-9 in the treatment of asthma - PMC \[pmc.ncbi.nlm.nih.gov\]](#)
- [23. Th2 cytokines and asthma — Interleukin-9 as a therapeutic target for asthma - PMC \[pmc.ncbi.nlm.nih.gov\]](#)
- [24. Reactome | Interleukin-9 signaling \[reactome.org\]](#)
- [25. Evaluation of Interleukin-9 Expression as a Potential Therapeutic Target in Chronic Lymphocytic Leukemia in a Cohort of Egyptian Patients - PMC \[pmc.ncbi.nlm.nih.gov\]](#)
- [To cite this document: BenchChem. \[An In-depth Technical Guide to PID-9 Target Identification and Validation\]. BenchChem, \[2026\]. \[Online PDF\]. Available at: \[https://www.benchchem.com/product/b12362773/docs#an-in-depth-technical-guide-to-pid-9-target-identification-and-validation\]](#)

---

#### Disclaimer & Data Validity:

The information provided in this document is for Research Use Only (RUO) and is strictly not intended for diagnostic or therapeutic procedures. While BenchChem strives to provide accurate protocols, we make no warranties, express or implied, regarding the fitness of this product for every specific experimental setup.

**Technical Support:** The protocols provided are for reference purposes. Unsure if this reagent suits your experiment?

**Need Industrial/Bulk Grade?** [Request Custom Synthesis Quote](#)

## BenchChem

Our mission is to be the trusted global source of essential and advanced chemicals, empowering scientists and researchers to drive progress in science and industry.

#### Contact

Address: 3281 E Guasti Rd  
Ontario, CA 91761, United States  
Phone: (601) 213-4426  
Email: [info@benchchem.com](mailto:info@benchchem.com)

Contact our Ph.D. Support Team for a compatibility check