

A Comparative Guide to Novel Kv7.2 Modulators for Preclinical Research

Author: BenchChem Technical Support Team. **Date:** April 2026

Compound of Interest

Compound Name: *Kv7.2 modulator 2*

Cat. No.: *B12362331*

[Get Quote](#)

For Researchers, Scientists, and Drug Development Professionals

This guide provides an objective comparison of a novel Kv7.2/7.3 potassium channel activator, BHV-7000, with the recently developed modulator CB03 and the first-generation Kv7 activator, Retigabine (Ezogabine). The activation of Kv7.2/7.3 channels, which generate the neuronal M-current, is a clinically validated mechanism for controlling neuronal hyperexcitability.[1][2] This makes modulators of these channels promising therapeutic candidates for epilepsy and other neurological disorders.[1][2] This document summarizes key preclinical data to aid in the evaluation and selection of these compounds for further investigation.

Mechanism of Action: Stabilizing Neuronal Brakes

Kv7.2 and Kv7.3 subunits co-assemble to form heterotetrameric potassium channels that are crucial for regulating neuronal excitability.[3][4] These channels are voltage-gated and their opening leads to an efflux of potassium ions, which hyperpolarizes the neuronal membrane. This hyperpolarization raises the threshold for action potential firing, thereby acting as a brake on excessive neuronal activity.[2] Small molecule modulators like BHV-7000, CB03, and Retigabine are positive allosteric modulators that bind to the channel and stabilize its open

conformation.[5] This action enhances the M-current, leading to a reduction in neuronal firing frequency.[6]

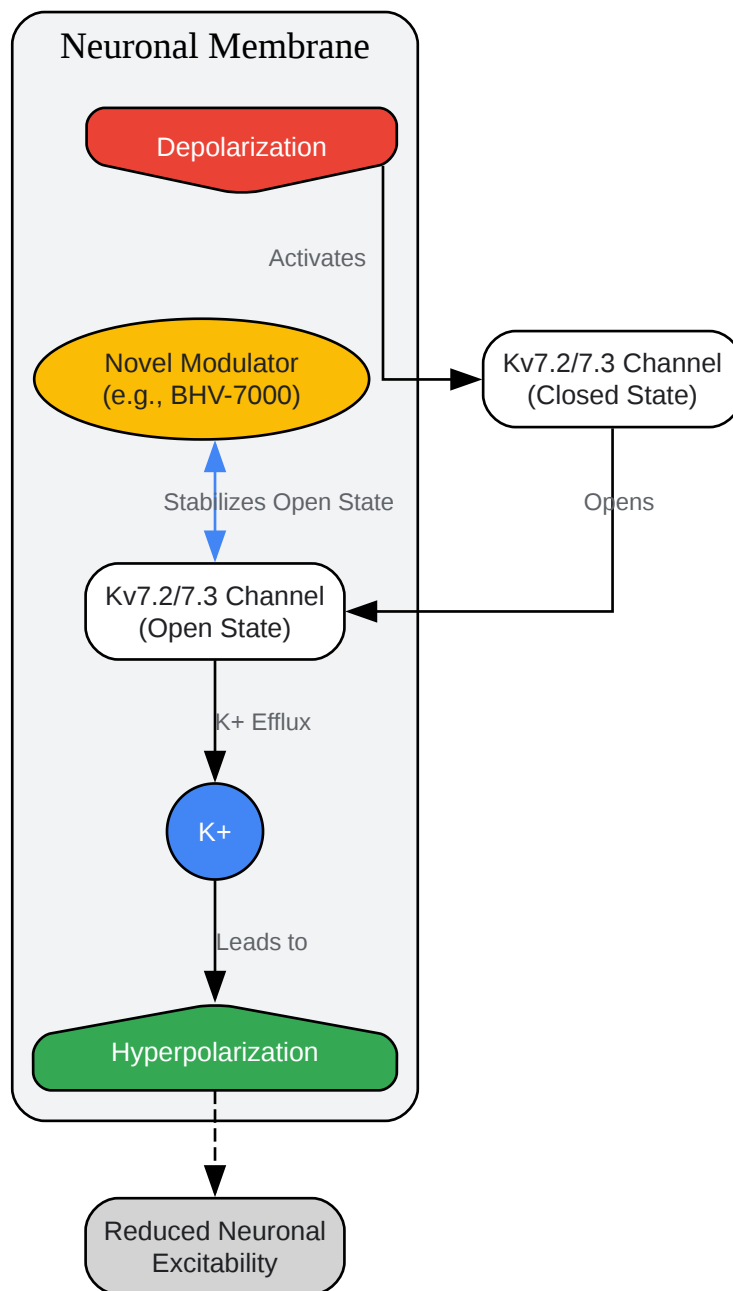

[Click to download full resolution via product page](#)

Mechanism of Kv7.2/7.3 Channel Activation

Comparative Preclinical Data

The following tables summarize the available preclinical data for BHV-7000, CB03, and Retigabine, focusing on their in vitro potency, in vivo efficacy in a key seizure model, and selectivity profile.

Table 1: In Vitro Potency on Kv7.2/7.3 Channels

Compound	Target	Assay System	EC50	Reference
BHV-7000	Human Kv7.2/7.3	Whole-cell patch clamp in CHO/HEK cells	0.6 μ M	[2]
CB03	Human KCNQ2/3	Not specified	High potency	[6][7]
Retigabine	Human Kv7.2/7.3	Not specified	~1-6 μ M	[8]

Table 2: In Vivo Efficacy in the Maximal Electroshock Seizure (MES) Model

Compound	Animal Model	Administration Route	ED50	Therapeutic Index (TD50/ED50)	Reference
BHV-7000	Rat	Not specified	0.5 mg/kg	>40	[2]
CB03	Mouse (ICR)	Not specified	Not specified	4.23 (male), 3.77 (female)	[6][7]
Retigabine	Rat	Not specified	20 mg/kg	<3	[2]

Table 3: Selectivity Profile and Off-Target Effects

Compound	Selectivity for Kv7.2/7.3	GABAA Receptor Activity	Reference
BHV-7000	Highly selective for Kv7.2/7.3.[1]	Minimal to no activation.[1][9][10][11]	[1][9][10][11]
CB03	Highly selective for KCNQ2/3 over KCNQ1 and other ion channels.[6][7]	Weak inhibitory effect.[6][7]	[6][7]
Retigabine	Broad spectrum activator of Kv7.2-7.5.[12][13]	Enhances currents through δ -subunit containing GABAA receptors.[5][8][14]	[5][8][12][13][14]

Experimental Protocols

Detailed methodologies for the key experiments cited are provided below to facilitate study replication and comparison.

Whole-Cell Patch Clamp Electrophysiology

This protocol is for recording Kv7.2/7.3 currents from transiently transfected mammalian cells (e.g., CHO or HEK293 cells).

1. Cell Preparation and Transfection:

- Culture CHO or HEK293 cells in appropriate growth medium.
- Co-transfect cells with plasmids encoding human Kv7.2 and Kv7.3 subunits, often with a fluorescent marker like GFP to identify transfected cells.
- Allow 24-48 hours post-transfection for channel expression before recording.

2. Solutions:

- Internal Pipette Solution (in mM): 140 K-gluconate, 9 NaCl, 1.8 MgCl₂, 0.09 EGTA, 9 HEPES, 14 Creatine Phosphate (Tris salt), 4 Mg-ATP, and 0.3 Tris-GTP. Adjust pH to 7.2 with KOH.
- External Bath Solution (in mM): 135 NaCl, 5 KCl, 2.8 Na acetate, 1 CaCl₂, 1 MgCl₂, and 10 HEPES. Adjust pH to 7.4 with NaOH.

3. Recording Procedure:

- Pull borosilicate glass pipettes to a resistance of 2-5 MΩ when filled with the internal solution.
- Establish a gigaohm seal (>1 GΩ) with a transfected cell.
- Rupture the cell membrane to achieve the whole-cell configuration.
- Use a patch-clamp amplifier and data acquisition system to record currents. Compensate for pipette and whole-cell capacitance.

4. Voltage-Clamp Protocol:

- Set the holding potential to -90 mV.
- To generate activation curves, apply depolarizing voltage steps from -100 mV to +40 mV in 10 mV increments for 500 ms.
- Measure the tail current amplitude upon repolarization to a fixed potential (e.g., -60 mV) to determine the extent of channel opening at each voltage step.

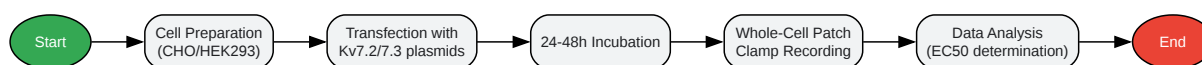

[Click to download full resolution via product page](#)

Experimental Workflow for In Vitro Potency

Maximal Electroschock Seizure (MES) Model in Rodents

The MES test is a well-validated preclinical model for generalized tonic-clonic seizures and is used to assess the anticonvulsant activity of test compounds.

1. Animals:

- Male CF-1 mice or Sprague-Dawley rats are commonly used.

2. Drug Administration:

- Administer the test compound (e.g., BHV-7000, CB03, Retigabine) or vehicle control via the desired route (e.g., oral, intraperitoneal).
- Test at various doses to determine the median effective dose (ED50).

3. Test Procedure:

- At the time of peak drug effect, apply a drop of local anesthetic (e.g., 0.5% tetracaine hydrochloride) to the corneas of the animal.
- Deliver a suprathreshold electrical stimulus through corneal electrodes. Typical parameters are:
 - Mice: 50 mA, 60 Hz for 0.2 seconds.
 - Rats: 150 mA, 60 Hz for 0.2 seconds.
- Observe the animal for the presence or absence of a tonic hindlimb extension seizure.

4. Endpoint and Data Analysis:

- The primary endpoint is the abolition of the tonic hindlimb extension component of the seizure. An animal is considered protected if this is absent.
- Calculate the percentage of animals protected at each dose and determine the ED50 using probit analysis.
- The therapeutic index can be calculated as the ratio of the median toxic dose (TD50, often assessed using a rotarod test for motor impairment) to the ED50.

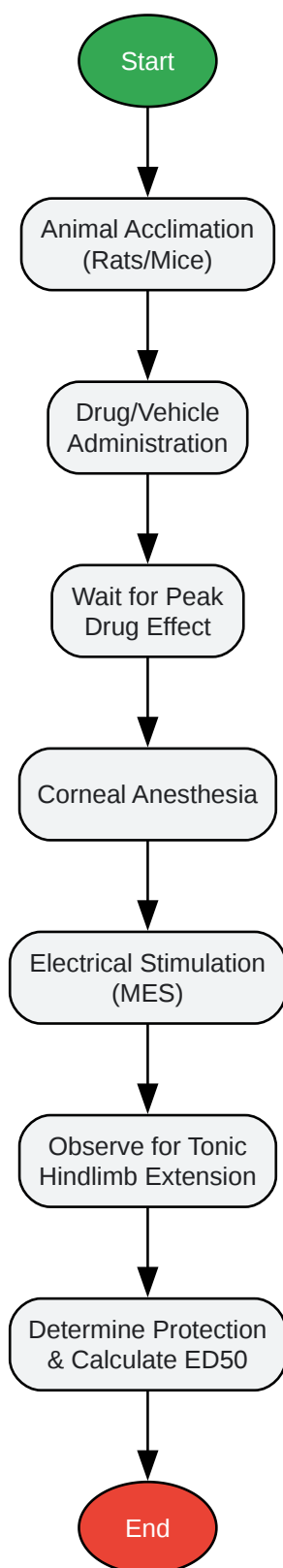

[Click to download full resolution via product page](#)

Experimental Workflow for In Vivo Efficacy (MES Model)

Need Custom Synthesis?

BenchChem offers custom synthesis for rare earth carbides and specific isotopic labeling.

Email: info@benchchem.com or [Request Quote Online](#).

References

- 1. Kv7 ION Channel Modulation Platform | Biohaven [biohaven.com]
- 2. biohaven.b-cdn.net [biohaven.b-cdn.net]
- 3. KCNQ2 and KCNQ5 form heteromeric channels independent of KCNQ3 - PMC [[pubmed.ncbi.nlm.nih.gov](https://pubmed.ncbi.nlm.nih.gov/12345678/)]
- 4. KCNQ2 and KCNQ5 form heteromeric channels independent of KCNQ3 - PubMed [[pubmed.ncbi.nlm.nih.gov](https://pubmed.ncbi.nlm.nih.gov/12345678/)]
- 5. Retigabine: the newer potential antiepileptic drug - PubMed [[pubmed.ncbi.nlm.nih.gov](https://pubmed.ncbi.nlm.nih.gov/12345678/)]
- 6. preclinical overview of cb03 kcnq2/3 channel opener for epilepsy [aesnet.org]
- 7. CB-03 selectively activates KCNQ2/3 channels and prevents seizures in models of epilepsy | BioWorld [bioworld.com]
- 8. The anticonvulsant retigabine is a subtype selective modulator of GABA A receptors - PMC [[pubmed.ncbi.nlm.nih.gov](https://pubmed.ncbi.nlm.nih.gov/12345678/)]
- 9. Biohaven Presents New Data with BHV-7000 Once-Daily Extended-Release Formulation Demonstrating Excellent Safety Profile and Nonclinical Data Updates at American Epilepsy Society 2024 Annual Meeting [prnewswire.com]
- 10. neurology.org [neurology.org]
- 11. phase 1 multiple ascending dose studies demonstrate safety and tolerability of bhv-7000, a novel kv7 potassium channel activator [aesnet.org]
- 12. Potent KCNQ2/3-Specific Channel Activator Suppresses In Vivo Epileptic Activity and Prevents the Development of Tinnitus - PMC [[pubmed.ncbi.nlm.nih.gov](https://pubmed.ncbi.nlm.nih.gov/12345678/)]
- 13. rupress.org [rupress.org]
- 14. The anticonvulsant retigabine is a subtype selective modulator of GABAA receptors - PubMed [[pubmed.ncbi.nlm.nih.gov](https://pubmed.ncbi.nlm.nih.gov/12345678/)]
- To cite this document: BenchChem. [A Comparative Guide to Novel Kv7.2 Modulators for Preclinical Research]. BenchChem, [2026]. [Online PDF]. Available at:

[<https://www.benchchem.com/product/b12362331/docs#a-comparative-guide-to-novel-kv7-2-modulators-for-preclinical-research>]

Disclaimer & Data Validity:

The information provided in this document is for Research Use Only (RUO) and is strictly not intended for diagnostic or therapeutic procedures. While BenchChem strives to provide accurate protocols, we make no warranties, express or implied, regarding the fitness of this product for every specific experimental setup.

Technical Support: The protocols provided are for reference purposes. Unsure if this reagent suits your experiment?

Need Industrial/Bulk Grade? [Request Custom Synthesis Quote](#)

BenchChem

Our mission is to be the trusted global source of essential and advanced chemicals, empowering scientists and researchers to drive progress in science and industry.

Contact

Address: 3281 E Guasti Rd
Ontario, CA 91761, United States
Phone: (601) 213-4426
Email: info@benchchem.com

[Contact our Ph.D. Support Team for a compatibility check](#)