

optimizing treatment duration with IRE1a-IN-2 for maximal effect

Author: BenchChem Technical Support Team. **Date:** April 2026

Compound of Interest

Compound Name: IRE1a-IN-2

Cat. No.: B12361880

[Get Quote](#)

Technical Support Center: Optimizing Treatment with IRE1 α -IN-2

Welcome to the technical support center for optimizing treatment duration with IRE1 α -IN-2. This resource is designed for researchers, scientists, and drug development professionals to help you achieve maximal effect in your experiments by providing detailed troubleshooting guides and frequently asked questions.

Frequently Asked Questions (FAQs)

Q1: What is the primary mechanism of action for IRE1 α -IN-2?

A1: IRE1 α -IN-2 is a potent inhibitor of the inositol-requiring enzyme 1 α (IRE1 α) kinase.^[1] By inhibiting the kinase activity of IRE1 α , it prevents its autophosphorylation, which is a critical step for the activation of its endoribonuclease (RNase) domain.^[1] This, in turn, blocks the unconventional splicing of X-box binding protein 1 (XBP1) mRNA, a key event in the unfolded protein response (UPR).^{[1][2]}

Q2: What are the key downstream effects of IRE1 α inhibition that I should measure to assess the efficacy of IRE1 α -IN-2?

A2: The primary downstream effects to monitor are the inhibition of XBP1 mRNA splicing and the modulation of IRE1 α -dependent decay (RIDD) of other mRNAs. Additionally, you can assess the phosphorylation status of downstream targets in the JNK signaling pathway, as IRE1 α can activate JNK signaling under prolonged ER stress.[3][4][5]

Q3: How do I determine the optimal starting concentration and treatment duration for IRE1 α -IN-2 in my specific cell line?

A3: If no prior data exists for your cell line, a good starting point is to perform a dose-response experiment with a wide range of concentrations (e.g., 10 nM to 10 μ M) at a standard time point (e.g., 24, 48, or 72 hours).[6] The optimal duration should be determined through a time-course experiment where you measure key readouts at multiple time points (e.g., 2, 6, 12, 24, 48 hours).[6]

Q4: What is the difference between the pro-survival and pro-apoptotic effects of IRE1 α , and how does treatment duration with an inhibitor like IRE1 α -IN-2 influence this?

A4: Under moderate ER stress, IRE1 α activation leads to XBP1 splicing, which upregulates genes that promote cell survival and adaptation.[7] However, under severe or prolonged ER stress, IRE1 α can switch to promoting apoptosis through RIDD and activation of the JNK pathway.[7] The duration of treatment with an IRE1 α inhibitor is critical. Short-term inhibition might primarily block the adaptive XBP1 splicing, while long-term inhibition could prevent the switch to a pro-apoptotic response. The "maximal effect" will depend on your experimental goal: promoting cell death or protecting cells from ER stress-induced apoptosis.

Troubleshooting Guides

Problem 1: I am not observing any inhibition of XBP1 splicing after treatment with IRE1 α -IN-2.

Possible Cause	Suggested Solution
Inhibitor Instability	Prepare fresh stock solutions of IRE1α-IN-2 for each experiment. Verify the stability of the compound in your specific cell culture medium over the time course of your experiment.
Incorrect Concentration	Perform a dose-response experiment to determine the optimal concentration for your cell line. The published EC50 of 0.82 μM is a starting point, but this can vary between cell types. ^[1]
Insufficient Treatment Duration	Conduct a time-course experiment. The kinetics of inhibition may be slower in your specific model. Measure XBP1 splicing at multiple time points (e.g., 2, 4, 8, 12, 24 hours).
Low IRE1α Activity	Ensure that your experimental conditions induce ER stress sufficiently to activate the IRE1α pathway. Use a positive control for ER stress induction, such as tunicamycin or thapsigargin.
Cell Permeability Issues	While less common for small molecules, consider using a different solvent or formulation if you suspect poor cell penetration.

Problem 2: I am observing significant cytotoxicity at concentrations where I expect to see specific IRE1α inhibition.

Possible Cause	Suggested Solution
Off-Target Effects	High concentrations of kinase inhibitors can lead to off-target effects.[8] Try to use the lowest effective concentration determined from your dose-response experiments. If possible, use a second, structurally different IRE1α inhibitor to confirm that the observed phenotype is on-target.
Prolonged Inhibition of Pro-Survival Pathway	Continuous blockade of the adaptive XBP1 splicing pathway can be detrimental to cells, especially under chronic ER stress. Consider shorter treatment durations or intermittent dosing schedules.
Cell Line Sensitivity	Some cell lines may be particularly dependent on the IRE1α pathway for survival, even under basal conditions. Assess the baseline activity of the IRE1α pathway in your cells.

Quantitative Data Summary

The following tables summarize data for other well-characterized IRE1α inhibitors. This data can be used as a reference for designing your experiments with IRE1α-IN-2.

Table 1: Time-Dependent Inhibition of XBP1 Splicing by an IRE1α Inhibitor (Example)

Treatment Duration	Concentration	% Inhibition of XBP1 Splicing	Cell Line	Reference
2 hours	10 μM	50%	HEK293T	[9]
4 hours	10 μM	85%	HEK293T	[9]
8 hours	10 μM	>95%	HEK293T	[9]
24 hours	5 μM	>90%	OVCAR8	[10]

Table 2: Effect of Treatment Duration on Cell Viability with an IRE1 α Inhibitor (Example)

Treatment Duration	Concentration	% Cell Viability	Cell Line	Reference
24 hours	25 μ M	80%	ND1 Mutant	[11]
48 hours	25 μ M	60%	ND1 Mutant	[11]
72 hours	25 μ M	45%	ND1 Mutant	[11]

Experimental Protocols

Protocol 1: Time-Course Analysis of XBP1 mRNA Splicing

- **Cell Seeding:** Plate your cells at a density that will ensure they are in the logarithmic growth phase throughout the experiment.
- **ER Stress Induction:** Treat cells with an ER stress-inducing agent (e.g., 1 μ g/mL tunicamycin or 1 μ M thapsigargin) for a predetermined time to activate the IRE1 α pathway.
- **Inhibitor Treatment:** Add IRE1 α -IN-2 at the desired concentration. Include a vehicle control (e.g., DMSO).
- **Time Points:** Harvest cells at various time points after inhibitor addition (e.g., 0, 2, 4, 8, 12, 24 hours).
- **RNA Extraction:** Isolate total RNA from the cell pellets using a standard protocol (e.g., TRIzol).
- **RT-PCR:** Perform reverse transcription followed by PCR using primers that flank the 26-nucleotide intron in the XBP1 mRNA.
- **Gel Electrophoresis:** Separate the PCR products on an agarose gel. The unspliced XBP1 will appear as a larger band, and the spliced XBP1 as a smaller band.
- **Quantification:** Quantify the band intensities using densitometry to determine the ratio of spliced to unspliced XBP1 at each time point.

Protocol 2: Western Blot Analysis of JNK Phosphorylation

- Cell Treatment: Follow steps 1-4 from Protocol 1.
- Protein Lysate Preparation: Lyse the cells in RIPA buffer supplemented with protease and phosphatase inhibitors.
- Protein Quantification: Determine the protein concentration of each lysate.
- SDS-PAGE and Western Blotting: Separate equal amounts of protein by SDS-PAGE and transfer to a PVDF membrane.
- Antibody Incubation: Probe the membrane with primary antibodies against phospho-JNK (Thr183/Tyr185) and total JNK. Use a loading control antibody (e.g., GAPDH or β -actin).
- Detection: Use an appropriate HRP-conjugated secondary antibody and a chemiluminescent substrate to visualize the bands.
- Densitometry: Quantify the band intensities and normalize the phospho-JNK signal to the total JNK signal.

Visualizations

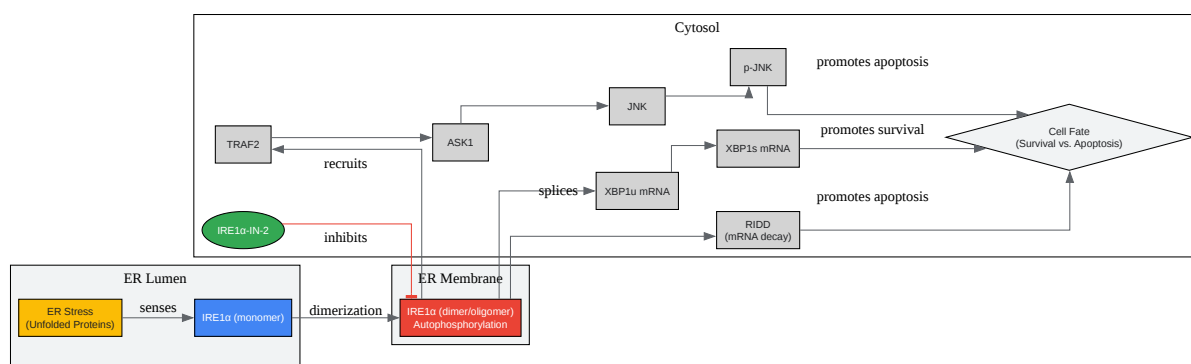

[Click to download full resolution via product page](#)

Caption: IRE1 α signaling pathway and the inhibitory action of IRE1 α -IN-2.

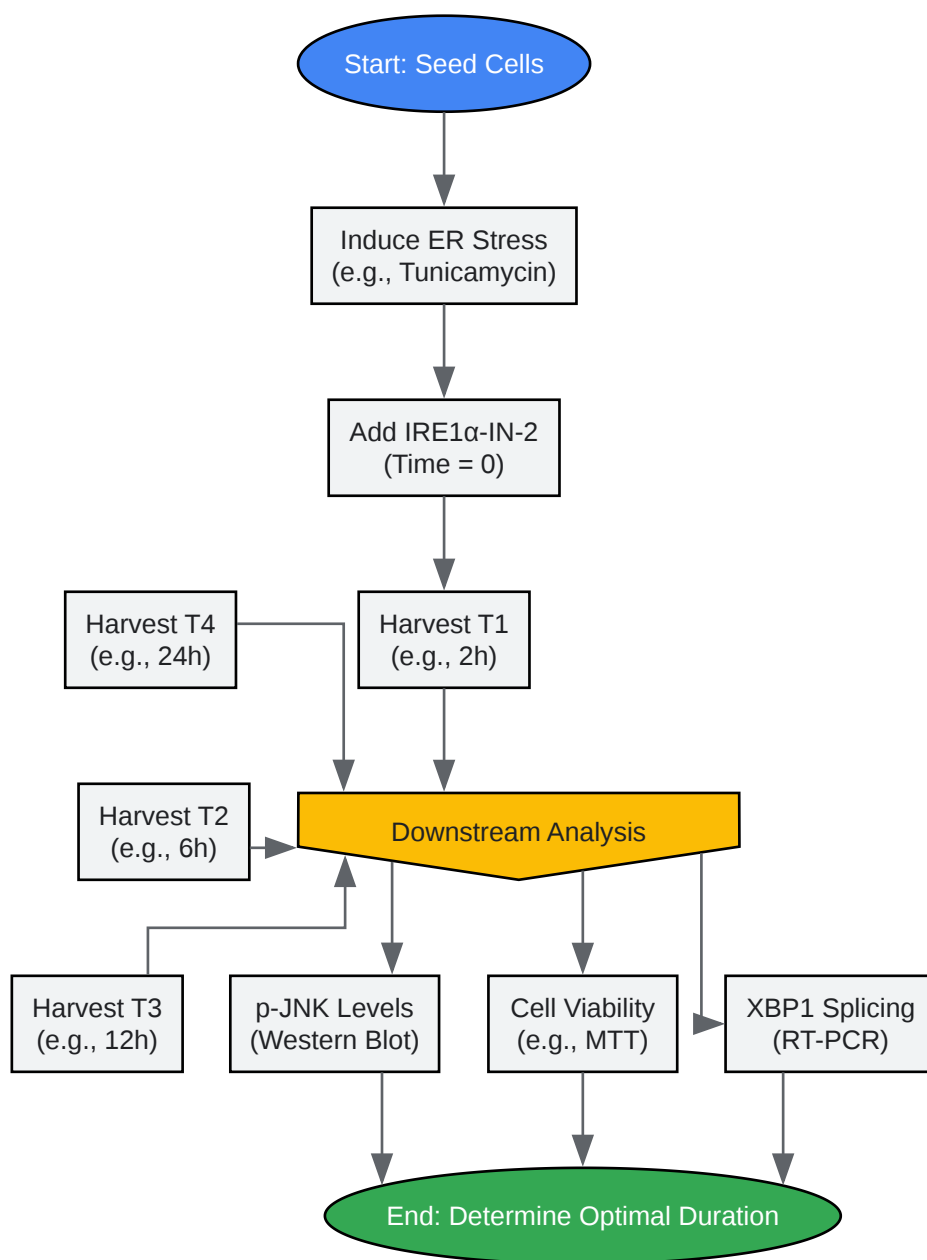

[Click to download full resolution via product page](#)

Caption: Experimental workflow for optimizing IRE1α-IN-2 treatment duration.

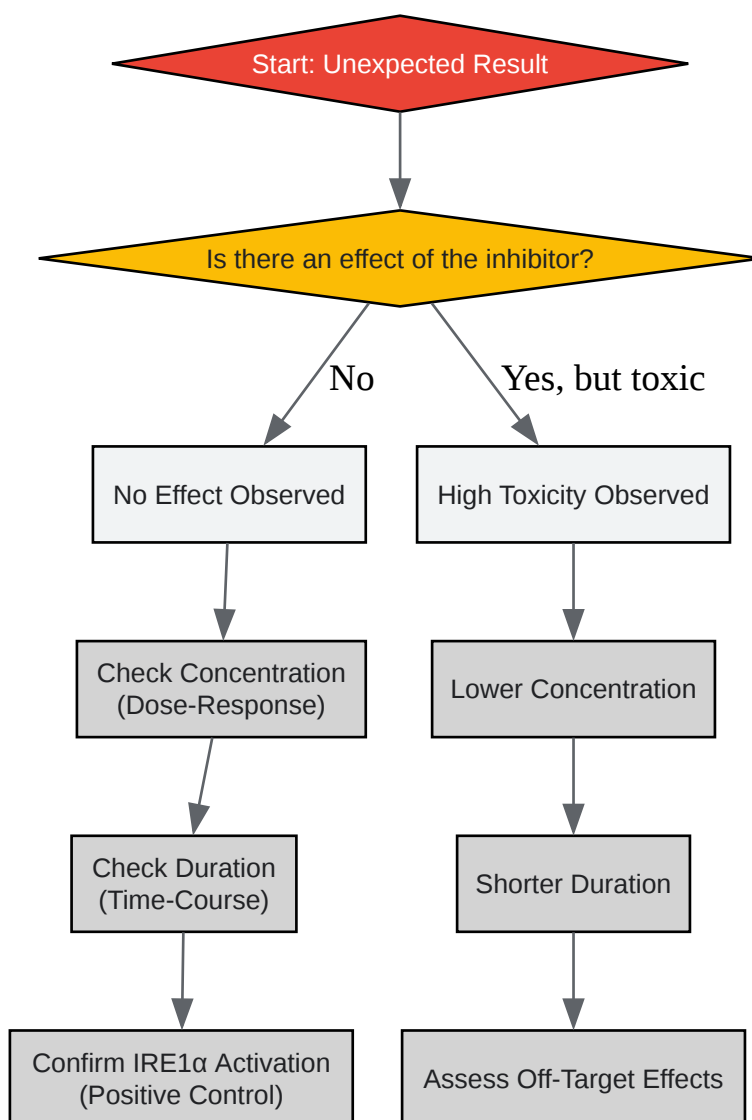

[Click to download full resolution via product page](#)

Caption: Troubleshooting decision tree for IRE1 α -IN-2 experiments.

Need Custom Synthesis?

BenchChem offers custom synthesis for rare earth carbides and specific isotopic labeling.

Email: info@benchchem.com or [Request Quote Online](#).

References

- 1. medchemexpress.com [medchemexpress.com]

- [2. benchchem.com \[benchchem.com\]](#)
- [3. An initial phase of JNK activation inhibits cell death early in the endoplasmic reticulum stress response - PMC \[pmc.ncbi.nlm.nih.gov\]](#)
- [4. researchgate.net \[researchgate.net\]](#)
- [5. Coupling of stress in the ER to activation of JNK protein kinases by transmembrane protein kinase IRE1 - PubMed \[pubmed.ncbi.nlm.nih.gov\]](#)
- [6. benchchem.com \[benchchem.com\]](#)
- [7. The Structure, Activation and Signaling of IRE1 and Its Role in Determining Cell Fate - PMC \[pmc.ncbi.nlm.nih.gov\]](#)
- [8. benchchem.com \[benchchem.com\]](#)
- [9. Endoplasmic reticulum stress-independent activation of unfolded protein response kinases by a small molecule ATP-mimic - PMC \[pmc.ncbi.nlm.nih.gov\]](#)
- [10. Inhibiting the IRE1 \$\alpha\$ Axis of the Unfolded Protein Response Enhances the Antitumor Effect of AZD1775 in TP53 Mutant Ovarian Cancer - PMC \[pmc.ncbi.nlm.nih.gov\]](#)
- [11. Inhibition of the ER stress IRE1 \$\alpha\$ inflammatory pathway protects against cell death in mitochondrial complex I mutant cells - PMC \[pmc.ncbi.nlm.nih.gov\]](#)
- To cite this document: BenchChem. [optimizing treatment duration with IRE1a-IN-2 for maximal effect]. BenchChem, [2026]. [Online PDF]. Available at: [\[https://www.benchchem.com/product/b12361880/docs#optimizing-treatment-duration-with-ire1a-in-2-for-maximal-effect\]](https://www.benchchem.com/product/b12361880/docs#optimizing-treatment-duration-with-ire1a-in-2-for-maximal-effect)

Disclaimer & Data Validity:

The information provided in this document is for Research Use Only (RUO) and is strictly not intended for diagnostic or therapeutic procedures. While BenchChem strives to provide accurate protocols, we make no warranties, express or implied, regarding the fitness of this product for every specific experimental setup.

Technical Support: The protocols provided are for reference purposes. Unsure if this reagent suits your experiment?

Need Industrial/Bulk Grade? [Request Custom Synthesis Quote](#)

BenchChem

Our mission is to be the trusted global source of essential and advanced chemicals, empowering scientists and researchers to drive progress in science and industry.

Contact

Address: 3281 E Guasti Rd

Ontario, CA 91761, United States

Phone: (601) 213-4426

Email: info@benchchem.com

[Contact our Ph.D. Support Team for a compatibility check](#)