

Enhancing the potency of TEAD ligand 1 through chemical modification

Author: BenchChem Technical Support Team. **Date:** April 2026

Compound of Interest

Compound Name: TEAD ligand 1

Cat. No.: B12361790

[Get Quote](#)

Technical Support Center: Enhancing TEAD Ligand 1 Potency

Welcome to the technical support center for the chemical modification of **TEAD Ligand 1**. This resource is designed for researchers, scientists, and drug development professionals to provide guidance and troubleshooting for experiments aimed at enhancing the potency of TEAD inhibitors.

Frequently Asked Questions (FAQs)

Q1: What are the common strategies for chemically modifying **TEAD Ligand 1** to improve its potency?

A1: Several strategies are employed to enhance the potency of **TEAD Ligand 1**. These include:

- Structure-Based Design: Utilizing the crystal structure of TEAD, particularly the palmitate-binding pocket, to design modifications that improve binding affinity.^{[1][2]}

- Covalent Inhibition: Introducing reactive groups ("warheads") that form a covalent bond with a specific residue in the TEAD binding pocket, often a conserved cysteine, leading to irreversible inhibition.[3][4]
- Fragment-Based Approaches: Identifying small fragments that bind to the TEAD protein and then growing or linking them to create more potent molecules.[5]
- Allosteric Modulation: Designing molecules that bind to a site other than the active site to modulate the protein's conformation and activity.[6][7]
- Inducing a Cofactor Switch: Certain modifications, such as the inclusion of a sulfonamide group, can promote the interaction of TEAD with the transcriptional repressor VGLL4, switching from a YAP/TAZ-activated state to a repressed state.[8][9][10][11]
- PROTACs (Proteolysis Targeting Chimeras): Designing bifunctional molecules that link a TEAD ligand to an E3 ubiquitin ligase ligand, leading to the targeted degradation of the TEAD protein.[12]

Q2: I have synthesized a new analog of **TEAD Ligand 1**, but it has poor aqueous solubility. What can I do?

A2: Poor aqueous solubility is a common challenge. Here are several approaches to address this issue:

- Chemical Modifications:
 - Salt Formation: For compounds with acidic or basic functional groups, forming a salt can significantly increase solubility.[6][13]
 - Introduction of Polar Functional Groups: Adding polar groups like hydroxyl (-OH), amino (-NH₂), or carboxyl (-COOH) can improve aqueous solubility.
 - Co-crystallization: Forming a co-crystal with a highly soluble, non-toxic co-former.[14]
- Formulation Strategies:

- Use of Co-solvents: Dissolving the compound in a mixture of a water-miscible organic solvent (e.g., DMSO, ethanol, PEG) and water.[14]
- Surfactants and Micellar Solubilization: Using surfactants to form micelles that can encapsulate the hydrophobic compound.[6][13]
- Nanosuspensions: Reducing the particle size of the compound to the nanometer range to increase the surface area for dissolution.[13]
- Inclusion Complexes: Using cyclodextrins to form inclusion complexes where the hydrophobic drug is encapsulated within the cyclodextrin cavity.[5][13]

Q3: My chemical synthesis of a **TEAD Ligand 1** analog resulted in a very low yield. How can I improve it?

A3: Low reaction yields can be addressed by optimizing several aspects of the synthesis:

- Reaction Conditions:
 - Temperature and Reaction Time: Systematically vary the temperature and reaction time to find the optimal conditions.[2]
 - Solvent: The choice of solvent can significantly impact reaction rates and yields.
 - Catalyst: If applicable, screen different catalysts and optimize the catalyst loading.
- Reagents and Stoichiometry:
 - Purity of Starting Materials: Ensure the purity of your starting materials, as impurities can interfere with the reaction.
 - Stoichiometry: Adjust the ratio of reactants to drive the reaction to completion.
- Work-up and Purification:
 - Minimize Transfer Losses: Be meticulous during the work-up and purification steps to avoid physical loss of the product.

- **Optimize Purification Method:** For column chromatography, ensure the correct stationary and mobile phases are used to achieve good separation and recovery. Adding a small amount of acid or base to the eluent can sometimes improve the resolution and yield for acidic or basic compounds, respectively.[14]
- **Protecting Groups:** If your molecule has multiple reactive sites, using protecting groups can prevent side reactions and improve the yield of the desired product.

Q4: My modified TEAD ligand is a covalent inhibitor, and I am concerned about off-target effects. How can I mitigate this risk?

A4: Off-target effects are a significant concern for covalent inhibitors. Here are some strategies to minimize them:

- **Warhead Reactivity:** The electrophilic "warhead" should be reactive enough to bind to the target but not so reactive that it binds indiscriminately to other proteins. This is often referred to as the "Goldilocks principle".[12]
- **Targeting Non-Catalytic Residues:** If possible, design the inhibitor to target a poorly conserved, non-catalytic residue within the binding pocket to improve selectivity over other proteins in the same family.[15]
- **Structure-Based Design:** Use the crystal structure of the target protein to design inhibitors that have high-affinity non-covalent interactions with the binding pocket, in addition to the covalent bond. This increases the inhibitor's specificity for the intended target.
- **Reversible Covalent Inhibition:** Consider designing reversible covalent inhibitors. These form a covalent bond that can be broken, potentially reducing the risk of long-term off-target toxicity.[15]
- **Thorough Off-Target Profiling:** Experimentally assess the off-target effects of your compound using techniques like activity-based protein profiling (ABPP).[16][17]

Troubleshooting Guides

Issue 1: Inconsistent results in TEAD luciferase reporter assay.

Possible Cause	Troubleshooting Step
Cell Viability Issues	Perform a cell viability assay (e.g., MTT, CellTiter-Glo) in parallel to ensure that the observed decrease in luciferase signal is not due to cytotoxicity of the compound.
Variable Transfection Efficiency	Use a co-transfected reporter (e.g., Renilla luciferase) to normalize the firefly luciferase signal for transfection efficiency.
Inconsistent Cell Seeding	Ensure a uniform cell density across all wells of the microplate. Variations in cell number will lead to variability in the luciferase signal.
Compound Precipitation	Visually inspect the wells for any signs of compound precipitation. If observed, consider the solubility enhancement techniques mentioned in the FAQs.
Signal Quenching	Some compounds can directly inhibit the luciferase enzyme or quench the luminescent signal. Test your compound in a cell-free luciferase assay to rule this out.

Issue 2: Low potency or loss of activity of a modified TEAD ligand.

Possible Cause	Troubleshooting Step
Steric Hindrance	The modification may be too bulky and clash with the binding pocket. Molecular docking studies can help visualize potential steric clashes. For example, replacing a phenyl group with a bulky carborane group has been shown to decrease binding affinity.[6]
Disruption of Key Interactions	The modification may have removed or altered a functional group that is critical for binding. Analyze the structure-activity relationship (SAR) of known TEAD inhibitors to identify key pharmacophores.
Poor Cell Permeability	The modified compound may not be able to efficiently cross the cell membrane to reach its intracellular target. Assess cell permeability using assays like the parallel artificial membrane permeability assay (PAMPA).
Metabolic Instability	The compound may be rapidly metabolized by the cells. Perform metabolic stability assays using liver microsomes or hepatocytes.
Incorrect Stereochemistry	If the molecule has chiral centers, ensure that the desired stereoisomer has been synthesized and isolated, as different stereoisomers can have vastly different biological activities.

Data Presentation

Table 1: Comparative Potency of Y-Shaped Covalent TEAD Inhibitors

Compound	TEAD1 IC50 (nM)	TEAD2 IC50 (nM)	TEAD3 IC50 (nM)	TEAD4 IC50 (nM)	Reporter Assay IC50 (nM)	NCI-H226 Proliferati on IC50 (nM)
14	20 ± 1	35 ± 12	19 ± 1	24 ± 4	24 ± 10	16
15	16 ± 4	33 ± 14	20 ± 4	24 ± 1	22 ± 10	25
16	148 ± 39	>10000	>10000	>10000	171 ± 88	150
17	430 ± 100	>10000	>10000	>10000	522 ± 263	290
22	20 ± 1	42 ± 13	17 ± 2	27 ± 2	17 ± 5	24

Data synthesized from[18].

Table 2: Antiproliferative Activity of TEAD PROTACs in NCI-H226 Cells

Compound	Linker Type	IC50 (µM)
16-22	Alkyl	~1
23	Ether	0.34
24	Ether	0.29
25	Ether	0.26
27	Ether (different tethering)	0.21
VT107 (inhibitor)	-	< 1

Data synthesized from[12].

Experimental Protocols

Protocol 1: General Synthesis of Y-Shaped Covalent TEAD Inhibitors

This protocol is a generalized procedure based on the synthesis of compound 22 (MYF-03-176) and its analogs.[18]

- Synthesis of the Core Scaffold: Start with the appropriate substituted pyridine or pyrimidine derivative.
- Introduction of the "Left" Arm: Perform a Suzuki or Sonogashira coupling to introduce the aryl or heteroaryl group that will occupy the lipid-binding pocket.
- Introduction of the "Right" Arm: Couple the core scaffold with a suitable boronic acid or other organometallic reagent to introduce the group that will interact with the hydrophilic pocket.
- Addition of the Covalent Warhead: In the final step, introduce the acrylamide or other electrophilic warhead through an amidation reaction.
- Purification: Purify the final compound using column chromatography followed by preparative HPLC to ensure high purity.
- Characterization: Confirm the structure and purity of the final compound using ¹H NMR, ¹³C NMR, and high-resolution mass spectrometry.

Protocol 2: TEAD Luciferase Reporter Assay

This protocol is a standard method for assessing the inhibition of TEAD transcriptional activity in cells.[19][20]

- Cell Seeding: Seed HEK293T or other suitable cells in a 96-well white, clear-bottom plate at a density that will result in 70-80% confluency at the time of transfection.
- Transfection: Co-transfect the cells with a TEAD-responsive firefly luciferase reporter plasmid and a constitutively expressed Renilla luciferase plasmid (for normalization) using a suitable transfection reagent.
- Compound Treatment: After 24 hours, replace the medium with fresh medium containing the test compounds at various concentrations. Include a vehicle control (e.g., DMSO).
- Incubation: Incubate the cells with the compounds for 24-48 hours.

- **Lysis and Luminescence Measurement:** Lyse the cells and measure the firefly and Renilla luciferase activities using a dual-luciferase reporter assay system and a luminometer.
- **Data Analysis:** Normalize the firefly luciferase signal to the Renilla luciferase signal for each well. Plot the normalized luciferase activity against the compound concentration and fit the data to a dose-response curve to determine the IC50 value.

Protocol 3: Time-Resolved Fluorescence Resonance Energy Transfer (TR-FRET) Assay for TEAD Binding

This biochemical assay measures the direct binding of an inhibitor to the TEAD protein.[\[18\]](#)[\[21\]](#)

- **Reagents:**
 - His-tagged TEAD-YBD (YAP-binding domain) recombinant protein.
 - A fluorescently labeled tracer molecule that binds to the TEAD palmitate-binding pocket (e.g., a FAM-labeled derivative of a known TEAD inhibitor).
 - A terbium- or europium-labeled anti-His antibody (donor fluorophore).
- **Assay Procedure:**
 - In a 384-well low-volume black plate, pre-incubate the His-TEAD-YBD protein with various concentrations of the test inhibitor for a defined period (e.g., 1-5 hours) to allow for binding.
 - Add the fluorescent tracer to the wells.
 - Add the TR-FRET donor (anti-His-Tb/Eu) to the wells.
 - Incubate the plate at room temperature to allow the binding to reach equilibrium.
- **Detection:** Measure the TR-FRET signal using a plate reader capable of time-resolved fluorescence detection, with excitation around 340 nm and emission at two wavelengths (e.g., 620 nm for the donor and 665 nm for the acceptor).

- Data Analysis: Calculate the TR-FRET ratio (acceptor emission / donor emission). The displacement of the fluorescent tracer by the inhibitor will result in a decrease in the TR-FRET signal. Plot the TR-FRET ratio against the inhibitor concentration and fit the data to a competition binding curve to determine the IC50 or Ki value.

Mandatory Visualizations

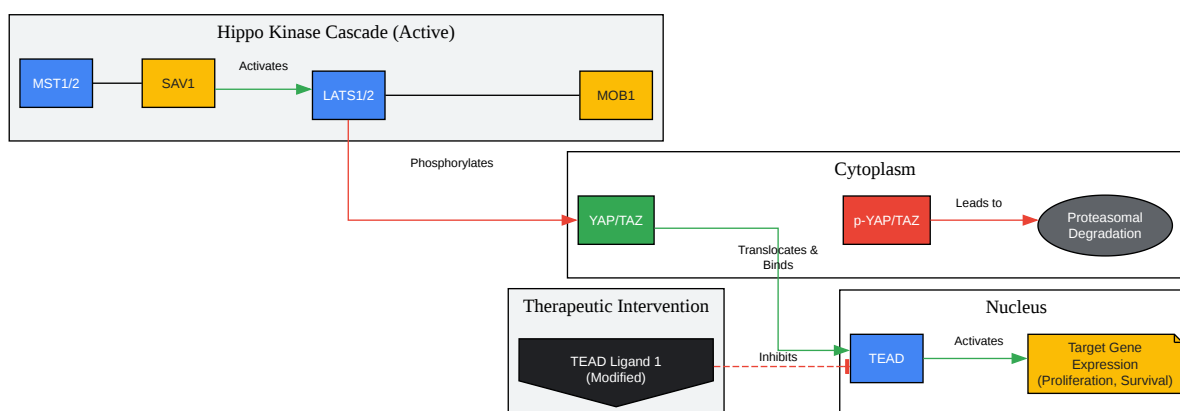

[Click to download full resolution via product page](#)

Caption: The Hippo-YAP/TAZ-TEAD signaling pathway and the point of intervention for TEAD inhibitors.

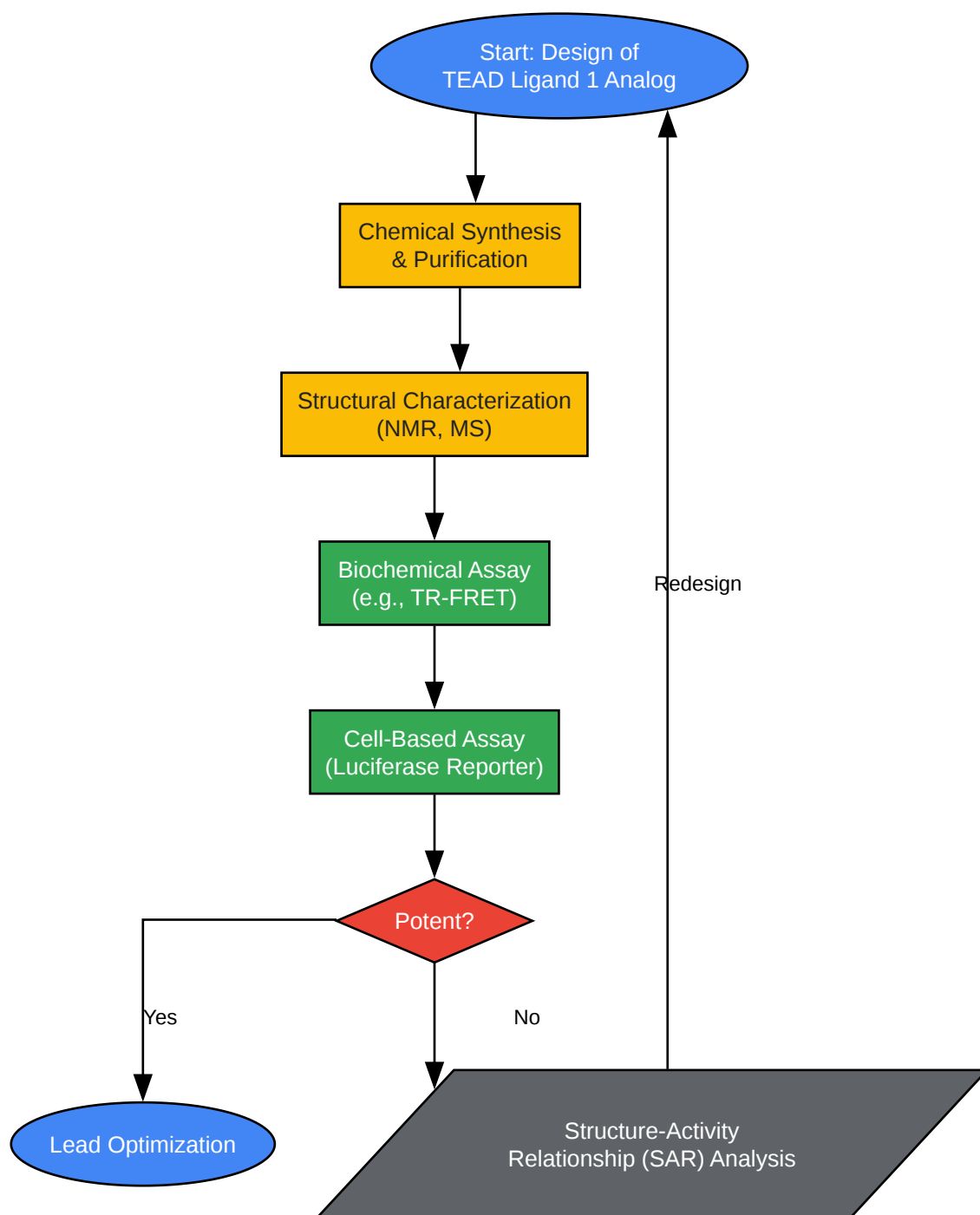

[Click to download full resolution via product page](#)

Caption: A general experimental workflow for the development and evaluation of modified **TEAD Ligand 1**.

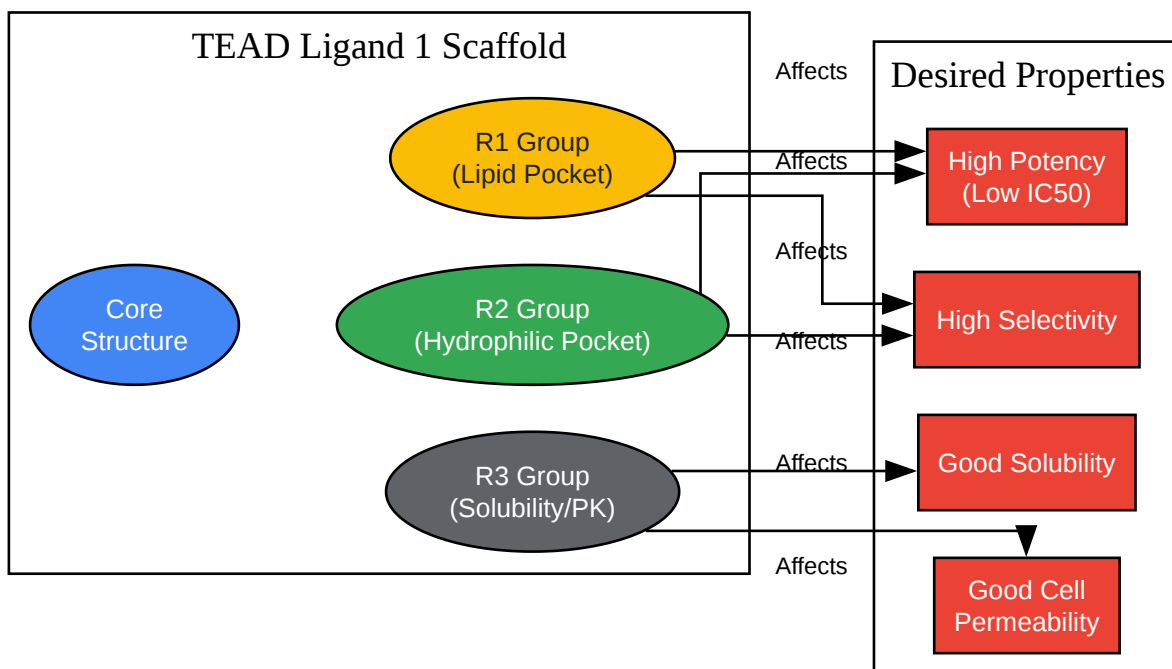

[Click to download full resolution via product page](#)

Caption: Logical relationship between chemical modifications and desired properties of **TEAD Ligand 1**.

Need Custom Synthesis?

BenchChem offers custom synthesis for rare earth carbides and specific isotopic labeling.

Email: info@benchchem.com or [Request Quote Online](#).

References

- 1. [researchgate.net](https://www.researchgate.net) [researchgate.net]
- 2. [quora.com](https://www.quora.com) [quora.com]
- 3. On Exploring Structure Activity Relationships - PMC [pmc.ncbi.nlm.nih.gov]
- 4. [researchgate.net](https://www.researchgate.net) [researchgate.net]
- 5. Drug Solubility: Importance and Enhancement Techniques - PMC [pmc.ncbi.nlm.nih.gov]
- 6. Solubility Enhancement Techniques | Pharmaguideline [pharmaguideline.com]

- [7. researchgate.net \[researchgate.net\]](https://www.researchgate.net)
- [8. solubilityofthings.com \[solubilityofthings.com\]](https://www.solubilityofthings.com)
- [9. Tips & Tricks \[chem.rochester.edu\]](https://chem.rochester.edu)
- [10. Structure-Based Design and Synthesis of Potent Cyclic Peptides Inhibiting the YAP–TEAD Protein–Protein Interaction - PMC \[pmc.ncbi.nlm.nih.gov\]](https://pubmed.ncbi.nlm.nih.gov/31111111/)
- [11. biorxiv.org \[biorxiv.org\]](https://www.biorxiv.org)
- [12. Covalent inhibitors in strategic therapeutic design | CAS \[cas.org\]](https://pubs.acs.org/doi/10.1021/acs.chemrev.3c00001)
- [13. brieflands.com \[brieflands.com\]](https://www.brieflands.com)
- [14. Reddit - The heart of the internet \[reddit.com\]](https://www.reddit.com)
- [15. Recent advances in the development of covalent inhibitors - PMC \[pmc.ncbi.nlm.nih.gov\]](https://pubmed.ncbi.nlm.nih.gov/31111111/)
- [16. Discovery of a subtype-selective, covalent inhibitor against palmitoylation pocket of TEAD3 - PMC \[pmc.ncbi.nlm.nih.gov\]](https://pubmed.ncbi.nlm.nih.gov/31111111/)
- [17. pubs.acs.org \[pubs.acs.org\]](https://pubs.acs.org)
- [18. Structure-Based Design of Y-Shaped Covalent TEAD Inhibitors - PMC \[pmc.ncbi.nlm.nih.gov\]](https://pubmed.ncbi.nlm.nih.gov/31111111/)
- [19. bpsbioscience.com \[bpsbioscience.com\]](https://www.bpsbioscience.com)
- [20. Luciferase Reporter Assays to Determine YAP/TAZ Activity in Mammalian Cells - PubMed \[pubmed.ncbi.nlm.nih.gov\]](https://pubmed.ncbi.nlm.nih.gov/31111111/)
- [21. dcreport.org \[dcreport.org\]](https://www.dcreport.org)
- To cite this document: BenchChem. [Enhancing the potency of TEAD ligand 1 through chemical modification]. BenchChem, [2026]. [Online PDF]. Available at: [\[https://www.benchchem.com/product/b12361790/docs#enhancing-the-potency-of-tead-ligand-1-through-chemical-modification\]](https://www.benchchem.com/product/b12361790/docs#enhancing-the-potency-of-tead-ligand-1-through-chemical-modification)

Disclaimer & Data Validity:

The information provided in this document is for Research Use Only (RUO) and is strictly not intended for diagnostic or therapeutic procedures. While BenchChem strives to provide accurate protocols, we make no warranties, express or implied, regarding the fitness of this product for every specific experimental setup.

Technical Support: The protocols provided are for reference purposes. Unsure if this reagent suits your experiment?

Need Industrial/Bulk Grade? [Request Custom Synthesis Quote](#)

BenchChem

Our mission is to be the trusted global source of essential and advanced chemicals, empowering scientists and researchers to drive progress in science and industry.

Contact

Address: 3281 E Guasti Rd
Ontario, CA 91761, United States
Phone: (601) 213-4426
Email: info@benchchem.com

[Contact our Ph.D. Support Team for a compatibility check](#)