

Application Notes and Protocols for PSMA Binder-2 Competition Assays

Author: BenchChem Technical Support Team. **Date:** April 2026

Compound of Interest

Compound Name: PSMA binder-2

Cat. No.: B12361945

[Get Quote](#)

For Researchers, Scientists, and Drug Development Professionals

Introduction

Prostate-Specific Membrane Antigen (PSMA) is a well-validated target for the diagnosis and treatment of prostate cancer. Competition binding assays are a cornerstone in the development of new PSMA-targeting agents, enabling the determination of binding affinity and specificity of novel ligands. This document provides detailed protocols and application notes for conducting competition assays with "**PSMA binder-2**," a precursor for the synthesis of advanced therapeutic agents like Ac-PSMA-trillium.[1][2]

The protocols outlined below describe both radioligand and fluorescence-based competition assays, which are fundamental techniques to quantify the interaction of a test compound (the unlabeled "competitor," such as **PSMA binder-2**) with PSMA by measuring its ability to displace a labeled ligand. The resulting data are crucial for calculating the half-maximal inhibitory concentration (IC₅₀) and the inhibition constant (K_i), which are key parameters in the characterization of a new binder.

Signaling Pathways and Experimental Logic

PSMA Signaling Pathway

PSMA expression influences key cellular signaling pathways involved in prostate cancer progression. In cells with high PSMA expression, there is a redirection of signaling from the MAPK/ERK pathway towards the PI3K-AKT pathway, which promotes tumor cell survival and growth.[3] Understanding this signaling switch is critical when evaluating the potential downstream effects of novel PSMA binders.

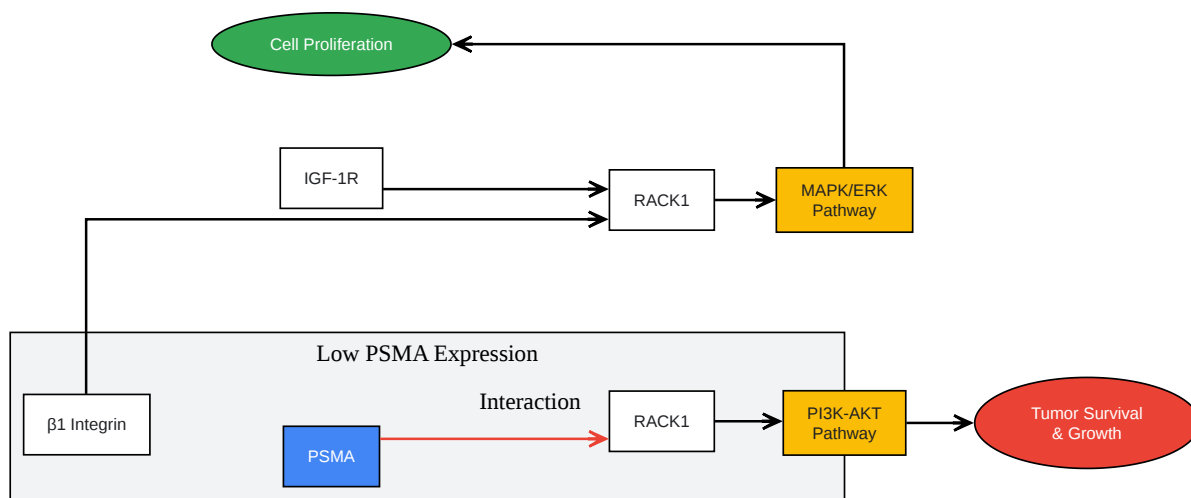

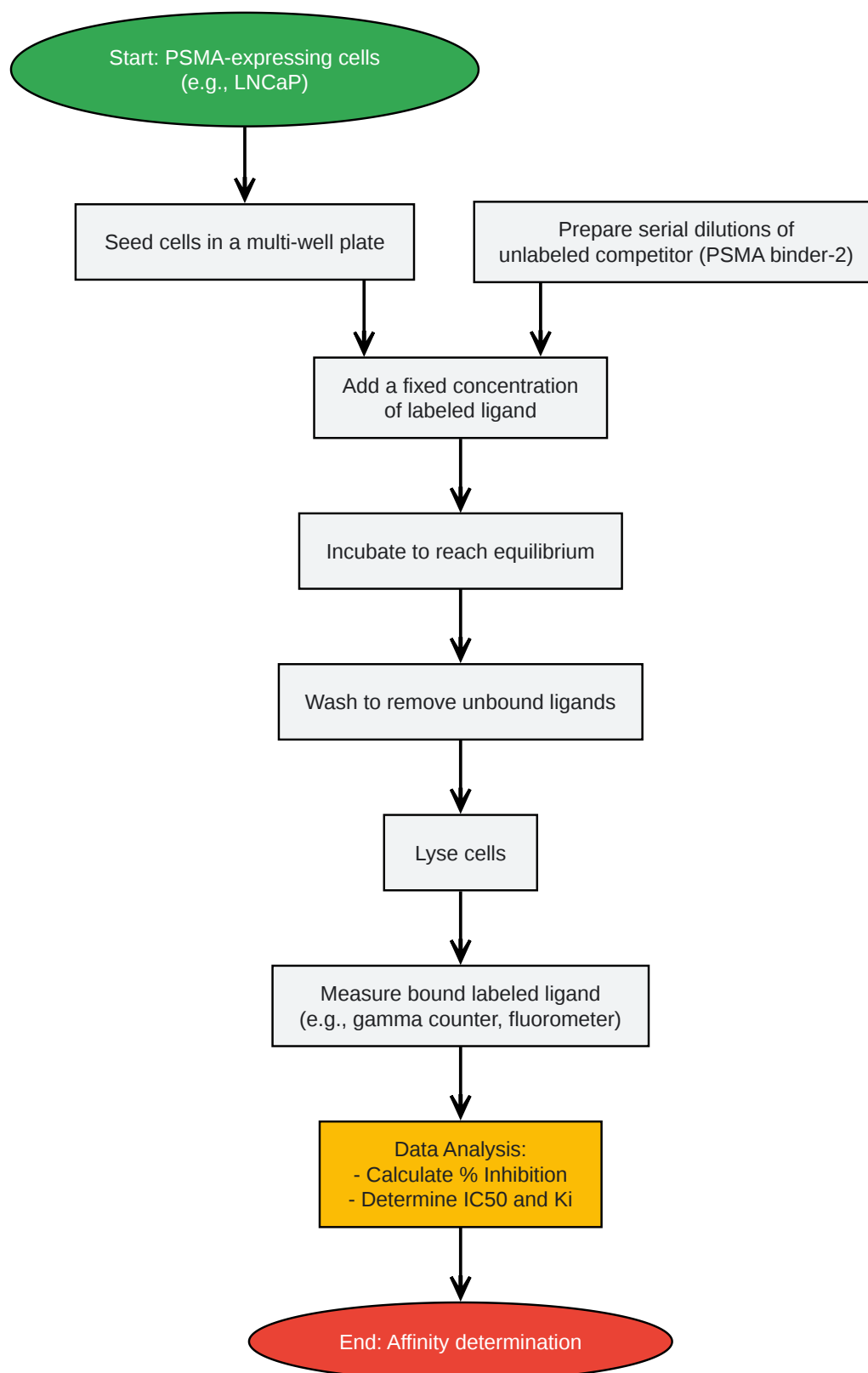

[Click to download full resolution via product page](#)

Need Custom Synthesis?

BenchChem offers custom synthesis for rare earth carbides and specific isotopic labeling.

Email: info@benchchem.com or [Request Quote Online](#).

References

- [1. medchemexpress.com \[medchemexpress.com\]](https://www.medchemexpress.com)
- [2. medchemexpress.com \[medchemexpress.com\]](https://www.medchemexpress.com)
- [3. benchchem.com \[benchchem.com\]](https://www.benchchem.com)
- To cite this document: BenchChem. [Application Notes and Protocols for PSMA Binder-2 Competition Assays]. BenchChem, [2026]. [Online PDF]. Available at: [\[https://www.benchchem.com/product/b12361945/docs#application-notes-and-protocols-for-psma-binder-2-competition-assays\]](https://www.benchchem.com/product/b12361945/docs#application-notes-and-protocols-for-psma-binder-2-competition-assays)

Disclaimer & Data Validity:

The information provided in this document is for Research Use Only (RUO) and is strictly not intended for diagnostic or therapeutic procedures. While BenchChem strives to provide accurate protocols, we make no warranties, express or implied, regarding the fitness of this product for every specific experimental setup.

Technical Support: The protocols provided are for reference purposes. Unsure if this reagent suits your experiment?

Need Industrial/Bulk Grade? [Request Custom Synthesis Quote](#)

BenchChem

Our mission is to be the trusted global source of essential and advanced chemicals, empowering scientists and researchers to drive progress in science and industry.

Contact

Address: 3281 E Guasti Rd
Ontario, CA 91761, United States
Phone: (601) 213-4426
Email: info@benchchem.com

Contact our Ph.D. Support Team for a compatibility check