

# Technical Support Center: Cefdinir MIC Determination Assays

**Author:** BenchChem Technical Support Team. **Date:** April 2026

## Compound of Interest

Compound Name: Cefdinir (Omnicef)

Cat. No.: B1236009

[Get Quote](#)

This technical support center provides troubleshooting guidance and frequently asked questions (FAQs) to help researchers, scientists, and drug development professionals minimize variability in Cefdinir Minimum Inhibitory Concentration (MIC) determination assays.

## Frequently Asked Questions (FAQs)

Q1: What are the primary sources of variability in Cefdinir MIC assays?

A1: Variability in Cefdinir MIC assays can arise from several factors. Key sources include the preparation and density of the bacterial inoculum, the stability and storage of Cefdinir stock solutions, the composition and pH of the culture medium (e.g., Mueller-Hinton Broth/Agar), and the incubation time and conditions.[1][2] Subjectivity in endpoint reading can also contribute to variability.[3]

Q2: Which standardized protocols should be followed for Cefdinir MIC determination?

A2: To ensure consistency and comparability of results, it is crucial to adhere to established standardized protocols. The Clinical and Laboratory Standards Institute (CLSI) documents M07 (broth dilution) and M02 (agar dilution) provide detailed methodologies for antimicrobial

susceptibility testing.[4][5] The European Committee on Antimicrobial Susceptibility Testing (EUCAST) also offers harmonized protocols.[6]

Q3: How should Cefdinir stock solutions be prepared and stored to maintain potency?

A3: Cefdinir stock solutions should be prepared using a suitable solvent, such as DMSO, and then diluted in the appropriate broth medium.[7] It is recommended to prepare fresh stock solutions for each assay. If storage is necessary, aliquot the stock solution and store it at -80°C for up to two years or at -20°C for up to one year to prevent degradation from repeated freeze-thaw cycles.[7]

Q4: What are the acceptable quality control (QC) ranges for Cefdinir MIC testing?

A4: Quality control is essential for ensuring the accuracy of MIC assays. Reference strains with known Cefdinir MIC values, such as *Staphylococcus aureus* ATCC 29213 and *Haemophilus influenzae* ATCC 49247, should be included in each run. The observed MIC for these QC strains must fall within the acceptable ranges specified by CLSI or EUCAST guidelines.

## Troubleshooting Guide

Problem 1: Inconsistent MIC Results for the Same Isolate Across Different Experiments

Possible Cause	Troubleshooting Step
Inoculum Density Variation	Ensure the bacterial suspension is standardized to a 0.5 McFarland turbidity standard before dilution. A heavier inoculum can lead to falsely elevated MICs, while a lighter inoculum can result in falsely low MICs.[1][8]
Cefdinir Stock Solution Degradation	Prepare a fresh stock solution of Cefdinir for each experiment. If using a frozen stock, ensure it has not undergone multiple freeze-thaw cycles.[7]
Media Composition Variability	Use cation-adjusted Mueller-Hinton Broth (CAMHB) from a reputable supplier. Variations in cation concentrations (Ca <sup>2+</sup> and Mg <sup>2+</sup> ) can affect the activity of some antimicrobials.[2] Ensure the pH of the media is within the recommended range (typically 7.2-7.4).[9]
Inconsistent Incubation Time	Strictly adhere to the recommended incubation time (usually 16-20 hours for non-fastidious bacteria). Shorter or longer incubation periods can alter the apparent MIC.[8]

## Problem 2: "Skipped Wells" Observed in Broth Microdilution Assays

Skipped wells are wells with no bacterial growth at a lower Cefdinir concentration, while growth is observed at a higher concentration.

Possible Cause	Troubleshooting Step
Contamination	Visually inspect the well for any signs of contamination. If suspected, repeat the assay with fresh materials. <a href="#">[1]</a>
Inadequate Inoculation or Mixing	Ensure the microtiter plate is inoculated correctly and that the inoculum is thoroughly mixed before dispensing into the wells. <a href="#">[1]</a>
Drug Precipitation	Cefdinir may precipitate at higher concentrations. Visually inspect the wells for any precipitate. If observed, preparing a fresh, properly solubilized stock solution may be necessary. <a href="#">[10]</a>

### Problem 3: "Trailing Endpoints" in Broth Microdilution

Trailing endpoints refer to reduced, but still visible, bacterial growth over a range of Cefdinir concentrations, making it difficult to determine the precise MIC.

Possible Cause	Troubleshooting Step
Reading Subjectivity	The endpoint should be read as the lowest concentration of Cefdinir that causes complete inhibition of visible growth. For some organism-drug combinations, reading after a shorter incubation period (e.g., 24 hours) may provide a clearer endpoint. <a href="#">[11]</a> <a href="#">[12]</a>
Media pH	The pH of the medium can influence the trailing phenomenon for some antimicrobials. Ensure the pH of the Mueller-Hinton broth is within the standardized range. <a href="#">[13]</a>

## Quantitative Data Summary

Table 1: Influence of Inoculum Size on MIC Values

Inoculum Density (CFU/mL)	Observed MIC Change	Reference
$3 \times 10^4$ to $3 \times 10^5$	69% of combinations showed no change, 30% showed a twofold increase, and 1% showed a fourfold increase.	[8]
$5 \times 10^5$ (Standard) vs. $5 \times 10^7$ (High)	A significant increase in MICs for cephalosporins against Bla-positive <i>S. aureus</i> was observed at the high inoculum.	[14]
Increase from $5 \times 10^6$ to $5 \times 10^7$	For <i>P. aeruginosa</i> , the MIC of piperacillin increased more than fourfold.	[15]

Table 2: Cefdinir MIC Breakpoints (CLSI)

Organism	Susceptible (S)	Intermediate (I)	Resistant (R)
Staphylococcus spp.	$\leq 1 \mu\text{g/mL}$	-	-
<i>S. pneumoniae</i>	$\leq 0.5 \mu\text{g/mL}$	-	-
Haemophilus spp.	$\leq 1 \mu\text{g/mL}$	-	-

Note: These breakpoints are for illustrative purposes and should be verified against the latest CLSI M100 document.

## Experimental Protocols

### Broth Microdilution MIC Assay for Cefdinir

This protocol is based on the CLSI M07 guidelines.[4]

- Preparation of Cefdinir Stock Solution:
  - Prepare a 1280  $\mu\text{g/mL}$  stock solution of Cefdinir in a suitable solvent (e.g., DMSO).

- Further dilutions are made in cation-adjusted Mueller-Hinton Broth (CAMHB).
- Preparation of Inoculum:
  - From a pure, overnight culture on an appropriate agar plate, select 3-4 colonies and suspend them in sterile saline.
  - Adjust the turbidity of the suspension to match a 0.5 McFarland standard (approximately  $1.5 \times 10^8$  CFU/mL).
  - Within 15 minutes, dilute the standardized suspension in CAMHB to achieve a final inoculum density of approximately  $5 \times 10^5$  CFU/mL in the microtiter plate wells.[16]
- Microtiter Plate Preparation and Inoculation:
  - Perform serial twofold dilutions of the Cefdinir stock solution in CAMHB in a 96-well microtiter plate to achieve the desired concentration range.
  - Inoculate each well with the prepared bacterial suspension.
  - Include a growth control well (no Cefdinir) and a sterility control well (no inoculum).
- Incubation:
  - Incubate the plate at  $35^\circ\text{C} \pm 2^\circ\text{C}$  for 16-20 hours in ambient air for non-fastidious organisms.
- Reading the MIC:
  - The MIC is the lowest concentration of Cefdinir that completely inhibits visible bacterial growth, as observed by the naked eye.

## Agar Dilution MIC Assay for Cefdinir

This protocol is based on the CLSI M02 and M07 guidelines.[17]

- Preparation of Cefdinir-Containing Agar Plates:
  - Prepare a series of Cefdinir stock solutions at 10 times the final desired concentrations.

- Add 1 part of each Cefdinir solution to 9 parts of molten Mueller-Hinton Agar (MHA) at 48-50°C.
- Pour the agar into sterile petri dishes and allow them to solidify.
- Include a drug-free control plate.
- Preparation of Inoculum:
  - Prepare a bacterial suspension equivalent to a 0.5 McFarland standard.
  - Dilute this suspension to achieve a final inoculum of approximately  $10^4$  CFU per spot.
- Inoculation:
  - Using an inoculum-replicating device, spot the bacterial suspension onto the surface of the Cefdinir-containing agar plates and the control plate.
- Incubation:
  - Incubate the plates at  $35^{\circ}\text{C} \pm 2^{\circ}\text{C}$  for 16-20 hours.
- Reading the MIC:
  - The MIC is the lowest concentration of Cefdinir that inhibits the visible growth of the bacteria on the agar surface.

## Visualizations

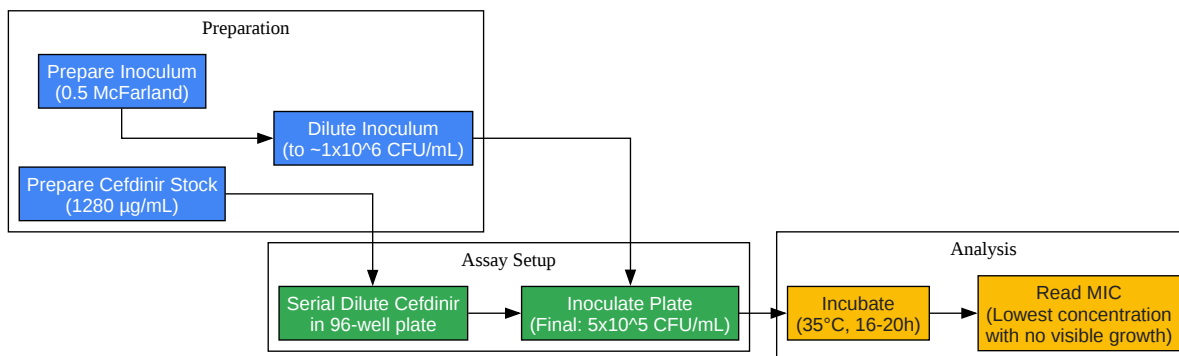

[Click to download full resolution via product page](#)

Caption: Workflow for Cefdinir Broth Microdilution MIC Assay.

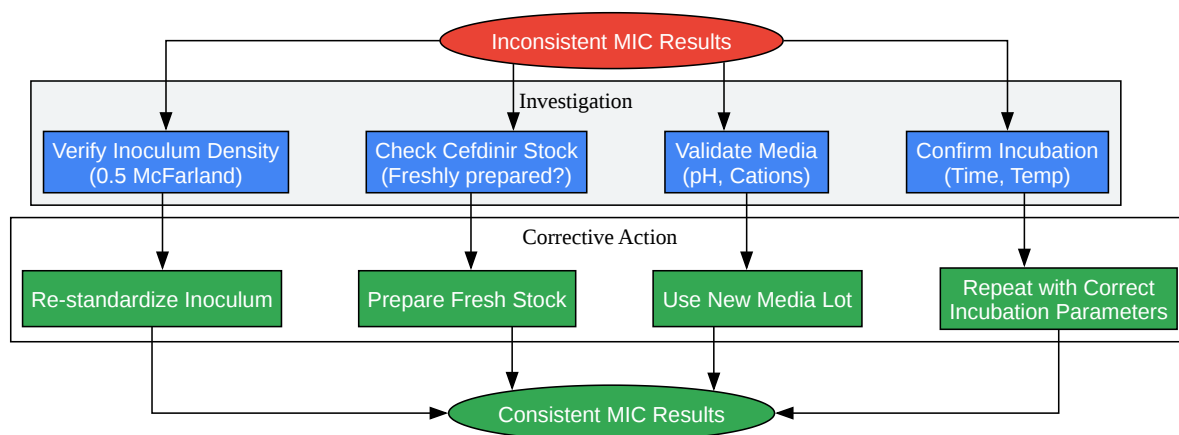

[Click to download full resolution via product page](#)

Caption: Troubleshooting Logic for Inconsistent Cefdinir MIC Results.

### **Need Custom Synthesis?**

*BenchChem offers custom synthesis for rare earth carbides and specific isotopic labeling.*

*Email: [info@benchchem.com](mailto:info@benchchem.com) or [Request Quote Online](#).*

## References

- [1. Broth Dilution Method for MIC Determination • Microbe Online \[microbeonline.com\]](#)
- [2. microbiologyinfo.com \[microbiologyinfo.com\]](#)
- [3. Broth Microdilution | MI \[microbiology.mlsascp.com\]](#)
- [4. M07 | Methods for Dilution Antimicrobial Susceptibility Tests for Bacteria That Grow Aerobically \[clsi.org\]](#)
- [5. M02 | Performance Standards for Antimicrobial Disk Susceptibility Tests \[clsi.org\]](#)
- [6. fwdamr-reflabcap.eu \[fwdamr-reflabcap.eu\]](#)
- [7. medchemexpress.com \[medchemexpress.com\]](#)
- [8. Effects of Inoculum Size and Incubation Time on Broth Microdilution Susceptibility Testing of Lactic Acid Bacteria - PMC \[pmc.ncbi.nlm.nih.gov\]](#)
- [9. contractlaboratory.com \[contractlaboratory.com\]](#)
- [10. benchchem.com \[benchchem.com\]](#)
- [11. Interpretation of trailing endpoints in antifungal susceptibility testing by the National Committee for Clinical Laboratory Standards method - PubMed \[pubmed.ncbi.nlm.nih.gov\]](#)
- [12. journals.asm.org \[journals.asm.org\]](#)
- [13. journals.asm.org \[journals.asm.org\]](#)
- [14. Determination of an Inoculum Effect with Various Cephalosporins among Clinical Isolates of Methicillin-Susceptible Staphylococcus aureus - PMC \[pmc.ncbi.nlm.nih.gov\]](#)
- [15. mdpi.com \[mdpi.com\]](#)
- [16. mdpi.com \[mdpi.com\]](#)
- [17. clsjournal.ascls.org \[clsjournal.ascls.org\]](#)

- To cite this document: BenchChem. [Technical Support Center: Cefdinir MIC Determination Assays]. BenchChem, [2026]. [Online PDF]. Available at: [<https://www.benchchem.com/product/b1236009/docs#technical-support-center-cefdinir-mic-determination-assays>]

---

### Disclaimer & Data Validity:

The information provided in this document is for Research Use Only (RUO) and is strictly not intended for diagnostic or therapeutic procedures. While BenchChem strives to provide accurate protocols, we make no warranties, express or implied, regarding the fitness of this product for every specific experimental setup.

**Technical Support:** The protocols provided are for reference purposes. Unsure if this reagent suits your experiment?

**Need Industrial/Bulk Grade?** [Request Custom Synthesis Quote](#)

## BenchChem

Our mission is to be the trusted global source of essential and advanced chemicals, empowering scientists and researchers to drive progress in science and industry.

### Contact

Address: 3281 E Guasti Rd  
Ontario, CA 91761, United States  
Phone: (601) 213-4426  
Email: [info@benchchem.com](mailto:info@benchchem.com)

[Contact our Ph.D. Support Team for a compatibility check](#)