

# Technical Support Center: Troubleshooting Caffeic Acid-pYEEIE Kinase Assay Variability

**Author:** BenchChem Technical Support Team. **Date:** April 2026

## Compound of Interest

Compound Name: Caffeic acid-pYEEIE

Cat. No.: B12353371

[Get Quote](#)

Welcome to the Technical Support Center for kinase assays involving Caffeic acid and the pYEEIE peptide substrate. This resource is designed for researchers, scientists, and drug development professionals to navigate and troubleshoot common sources of variability in their experiments.

## Frequently Asked Questions (FAQs)

Q1: What is the likely kinase target for the pYEEIE peptide substrate?

A1: The pYEEIE peptide sequence is a canonical recognition motif for Src family kinases (SFKs) and Abl kinase.<sup>[1][2][3]</sup> The presence of a central tyrosine (Y) residue as the phosphorylation site, preceded by acidic residues (E) and followed by a hydrophobic residue (I), is characteristic of substrates for these non-receptor tyrosine kinases. Therefore, when working with this peptide, it is crucial to consider the experimental context and the specific kinase being investigated.

Q2: Caffeic acid is my inhibitor of interest. What is its general mechanism of action against kinases?

A2: Caffeic acid, a phenolic phytochemical, has been shown to inhibit several kinases through various mechanisms. It can act as an ATP-competitive inhibitor, meaning it binds to the same site as ATP, or as a non-competitive inhibitor by binding to an allosteric site.[4] For instance, studies have demonstrated that Caffeic acid directly inhibits Fyn kinase, a member of the Src family, in a non-competitive manner with respect to ATP.[4] Understanding the mode of inhibition is critical for assay design, particularly concerning ATP concentration.

Q3: I am observing high variability between my replicate wells. What are the common culprits?

A3: High variability in kinase assays can stem from several factors:

- **Pipetting Inaccuracy:** Small volumes are often used in kinase assays, making them sensitive to pipetting errors. Ensure your pipettes are calibrated and use reverse pipetting for viscous solutions.
- **Inadequate Mixing:** Incomplete mixing of reagents, especially the enzyme or inhibitor, can lead to inconsistent reaction rates. Gently mix all components thoroughly.
- **Edge Effects:** The outer wells of a microplate are more prone to evaporation, which can concentrate reagents and alter reaction kinetics. It is advisable to either avoid using the outer wells or fill them with a buffer to maintain humidity.
- **Temperature Gradients:** Inconsistent temperature across the assay plate during incubation can lead to variability. Ensure the plate is incubated on a surface with uniform temperature.

Q4: My Caffeic acid inhibitor shows a much higher IC<sub>50</sub> value than expected. What could be the reason?

A4: An unexpectedly high IC<sub>50</sub> value for Caffeic acid could be due to:

- **High ATP Concentration:** If Caffeic acid is an ATP-competitive inhibitor, a high concentration of ATP in the assay will compete with the inhibitor, leading to a higher apparent IC<sub>50</sub>. It is recommended to use an ATP concentration at or near the K<sub>m</sub> for the specific kinase.[5]
- **Compound Solubility:** Phenolic compounds like Caffeic acid can have limited solubility in aqueous buffers. Precipitation of the compound will reduce its effective concentration. The

use of a co-solvent like DMSO is common, but its final concentration should be optimized and kept consistent across all wells.[6]

- **Incorrect Buffer Composition:** The pH, ionic strength, and presence of additives in the assay buffer can influence both enzyme activity and inhibitor binding. Ensure the buffer conditions are optimal for your target kinase.

## Troubleshooting Guides

This section provides a structured approach to resolving specific issues you may encounter during your **Caffeic acid-pYEEIE** kinase assay.

### Issue 1: Low Signal or Weak Kinase Activity

Potential Cause	Troubleshooting Step
Suboptimal Enzyme Concentration	Perform an enzyme titration to determine the optimal concentration that yields a robust signal within the linear range of the assay.
Inactive Enzyme	Ensure the kinase is properly stored and handled to maintain its activity. Avoid repeated freeze-thaw cycles.
Suboptimal Substrate Concentration	Titrate the pYEEIE peptide to determine its optimal concentration. Substrate inhibition can occur at very high concentrations.[7]
Incorrect Buffer Conditions	Verify that the pH, salt concentration, and necessary co-factors (e.g., $Mg^{2+}$ , $Mn^{2+}$ ) in your kinase assay buffer are optimal for the target kinase (e.g., Src or Abl).
Insufficient Incubation Time	Optimize the reaction time to ensure the reaction proceeds long enough to generate a detectable signal but remains within the linear phase.

### Issue 2: High Background Signal

Potential Cause	Troubleshooting Step
Contaminating Kinase Activity	If using cell lysates, there may be other kinases that can phosphorylate the pYEEIE peptide. Consider using a more purified enzyme preparation or specific inhibitors for contaminating kinases.
Non-enzymatic Phosphorylation	Run a control reaction without the kinase to check for non-enzymatic phosphorylation of the substrate.
Autophosphorylation of the Kinase	If the kinase autophosphorylates, this can contribute to the background. This is particularly relevant in radiometric assays where total phosphorylation is measured.
Assay Reagent Interference	Some assay components may interfere with the detection method (e.g., autofluorescence of Caffeic acid in fluorescence-based assays). Run appropriate controls with the compound alone.

## Issue 3: Inconsistent IC50 Values

Potential Cause	Troubleshooting Step
Variable DMSO Concentration	Ensure the final DMSO concentration is the same in all wells, including controls. High concentrations of DMSO can inhibit or sometimes stimulate kinase activity.[8]
Caffeic Acid Instability	Prepare fresh dilutions of Caffeic acid for each experiment, as phenolic compounds can be susceptible to oxidation.
Assay Not at Steady-State	Ensure your assay conditions are under initial velocity conditions, where the rate of product formation is linear with time. This is crucial for accurate IC50 determination.
Batch-to-Batch Reagent Variability	Use reagents from the same lot for a given set of experiments to minimize variability.

## Data Presentation

### Table 1: Recommended Concentration Ranges for Key Assay Components

Component	Typical Concentration Range	Notes
Src/Abl Kinase	2-20 U/reaction or 5-50 nM	Optimal concentration should be determined empirically by titration.[9][10]
pYEEIE Peptide Substrate	50-200 $\mu$ M	The concentration should ideally be around the $K_m$ of the kinase for the peptide.
ATP	10-100 $\mu$ M	Should be at or near the $K_m$ for the specific kinase to ensure sensitivity to ATP-competitive inhibitors.
Caffeic Acid	0.1 - 100 $\mu$ M	A wide range should be tested to determine the $IC_{50}$ . $IC_{50}$ values for Caffeic acid in cell-based assays are often in the 9-12 $\mu$ M range.[9]
DMSO	0.1 - 1% (v/v)	The final concentration should be kept constant and as low as possible to avoid off-target effects.[11]
MgCl <sub>2</sub>	5-20 mM	Essential co-factor for kinase activity.[12]
MnCl <sub>2</sub>	2-10 mM	Can sometimes enhance the activity of certain tyrosine kinases.[12]

## Table 2: Caffeic Acid $IC_{50}$ Values in Different Cancer Cell Lines

Cell Line	Cancer Type	IC50 ( $\mu\text{M}$ )	Citation
PC-3	Prostate Cancer	9.0	[9]
LNCaP	Prostate Cancer	11.5	[9]
K562 (Imatinib-sensitive)	Chronic Myeloid Leukemia	> 100 (low activity)	[6]
HT-1080	Fibrosarcoma	Potent anticancer effect observed	[13]
MCF-7	Breast Cancer	Varies with study	[14]

Note: These are IC50 values from cell viability assays and may not directly reflect the IC50 for direct kinase inhibition.

## Experimental Protocols

### Protocol 1: Radiometric Kinase Assay for Src/Abl Kinase

This protocol is adapted for a standard radiometric assay using  $[\gamma\text{-}^{32}\text{P}]\text{ATP}$ .

Materials:

- Purified active Src or Abl kinase
- pYEEIE peptide substrate
- Caffeic acid stock solution in DMSO
- Kinase Assay Buffer (e.g., 50 mM Tris-HCl pH 7.5, 10 mM  $\text{MgCl}_2$ , 1 mM EGTA, 2 mM DTT, 0.01% Brij-35)
- $[\gamma\text{-}^{32}\text{P}]\text{ATP}$
- Cold ATP stock solution
- Phosphocellulose paper (e.g., P81)

- Wash Buffer (e.g., 0.75% phosphoric acid)
- Scintillation counter and vials

Procedure:

- Prepare Reagents: Thaw all reagents on ice. Prepare a working solution of ATP by mixing cold ATP and [ $\gamma$ - $^{32}$ P]ATP in kinase assay buffer to the desired final concentration (e.g., 50  $\mu$ M).
- Set up Reactions: In a microcentrifuge tube, add the following in order:
  - Kinase Assay Buffer
  - Diluted Caffeic acid or DMSO (vehicle control)
  - pYEEIE peptide substrate (e.g., to a final concentration of 100  $\mu$ M)
  - Diluted Src/Abl kinase (e.g., to a final concentration of 10 nM)
- Pre-incubation: Gently mix and pre-incubate the reaction mixture for 10 minutes at 30°C.
- Initiate Reaction: Start the kinase reaction by adding the ATP working solution. The final reaction volume is typically 25-50  $\mu$ L.
- Incubation: Incubate the reaction at 30°C for a predetermined optimal time (e.g., 20-30 minutes), ensuring the reaction stays within the linear range.
- Stop Reaction: Terminate the reaction by spotting a portion of the reaction mixture (e.g., 20  $\mu$ L) onto a phosphocellulose paper square.
- Washing: Immediately place the phosphocellulose paper in a beaker with Wash Buffer. Wash three times for 5 minutes each with gentle stirring to remove unincorporated [ $\gamma$ - $^{32}$ P]ATP.[\[12\]](#)
- Quantification: After a final rinse with acetone to air dry, place the paper in a scintillation vial with scintillation fluid and measure the incorporated radioactivity using a scintillation counter.

## Protocol 2: Fluorescence Polarization (FP) Kinase Assay

This protocol provides a non-radioactive alternative for measuring kinase activity.

#### Materials:

- Purified active Src or Abl kinase
- pYEEIE peptide substrate
- Caffeic acid stock solution in DMSO
- Kinase Assay Buffer
- ATP
- A fluorescently labeled phosphopeptide tracer (with a sequence similar to phosphorylated pYEEIE)
- A phospho-tyrosine specific antibody
- A black, low-volume 384-well plate
- A plate reader capable of measuring fluorescence polarization

#### Procedure:

- Kinase Reaction:
  - In the wells of the 384-well plate, add the kinase, pYEEIE substrate, and Caffeic acid (or DMSO).
  - Initiate the reaction by adding ATP.
  - Incubate at room temperature for the optimized reaction time (e.g., 60 minutes).
- Stop and Detect:
  - Stop the kinase reaction by adding a stop solution containing EDTA.

- Add the mixture of the phospho-tyrosine antibody and the fluorescently labeled phosphopeptide tracer.
- Equilibration: Incubate the plate for at least 30 minutes at room temperature to allow the antibody-tracer binding to reach equilibrium.
- Measurement: Read the fluorescence polarization on a suitable plate reader. The signal will decrease as the unlabeled phosphorylated pYEEIE peptide produced by the kinase displaces the fluorescent tracer from the antibody.[15]

## Mandatory Visualizations

### Signaling Pathway

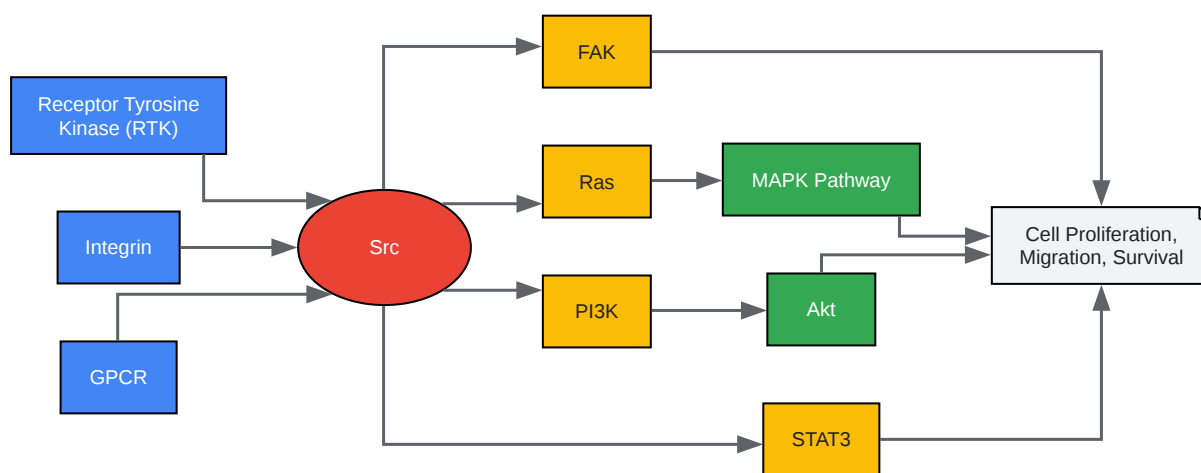

[Click to download full resolution via product page](#)

Caption: Simplified Src signaling pathway.[1][16]

## Experimental Workflow

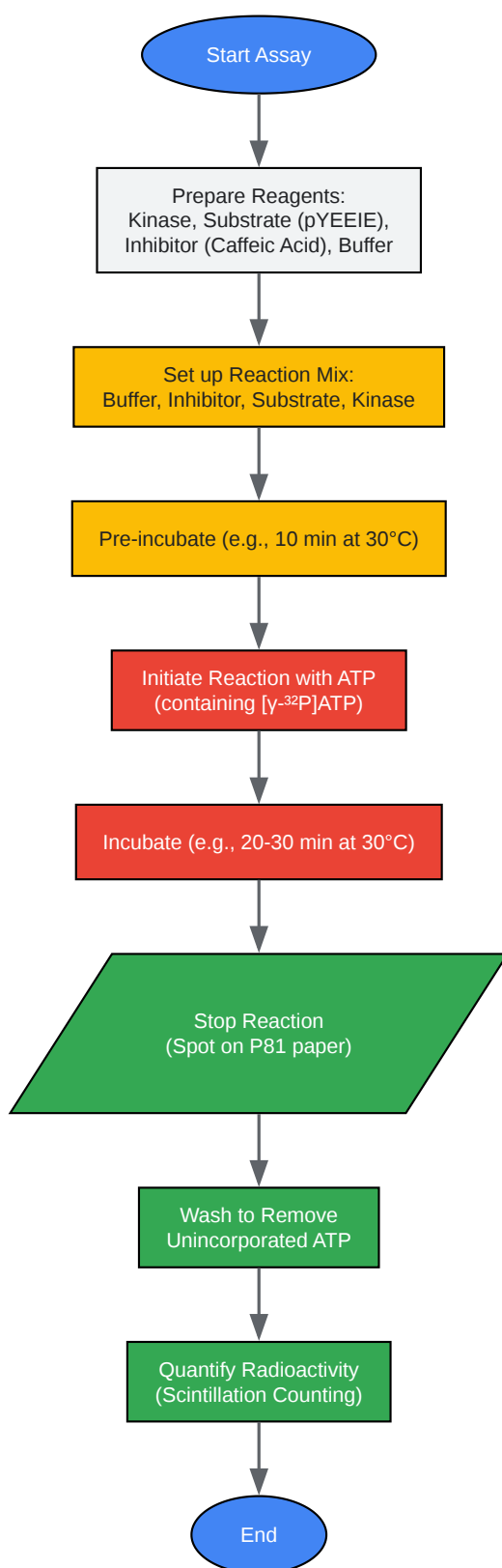

[Click to download full resolution via product page](#)

Caption: Workflow for a radiometric kinase assay.

## Troubleshooting Logic

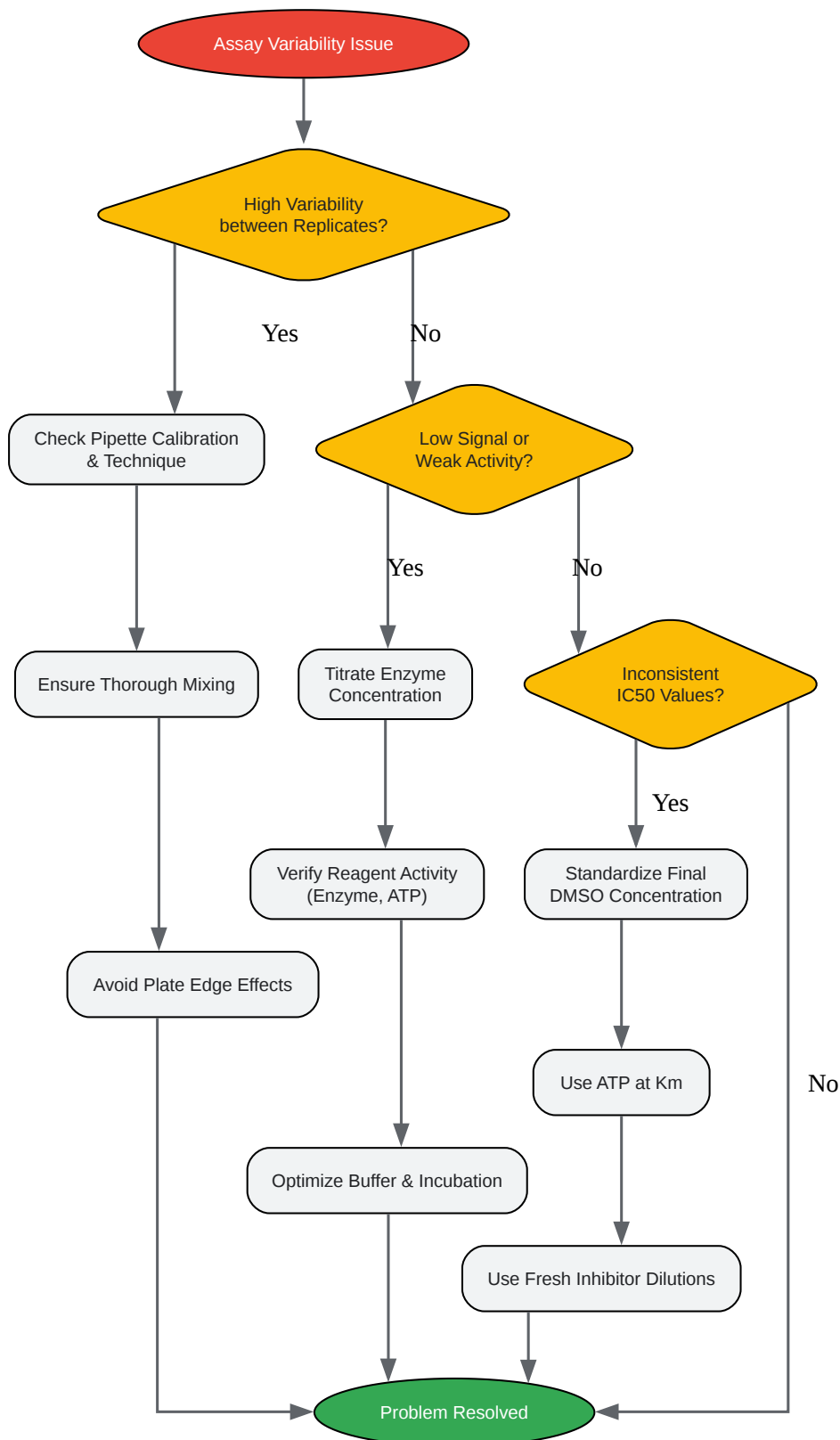

[Click to download full resolution via product page](#)

Caption: A logical flow for troubleshooting common kinase assay issues.

### Need Custom Synthesis?

BenchChem offers custom synthesis for rare earth carbides and specific isotopic labeling.

Email: [info@benchchem.com](mailto:info@benchchem.com) or [Request Quote Online](#).

## References

- [1. researchgate.net \[researchgate.net\]](#)
- [2. promega.com \[promega.com\]](#)
- [3. sinobiological.com \[sinobiological.com\]](#)
- [4. Caffeic acid, a phenolic phytochemical in coffee, directly inhibits Fyn kinase activity and UVB-induced COX-2 expression - PubMed \[pubmed.ncbi.nlm.nih.gov\]](#)
- [5. benchchem.com \[benchchem.com\]](#)
- [6. mdpi.com \[mdpi.com\]](#)
- [7. Modulation of Src Kinase Activity by Selective Substrate Recognition with Pseudopeptidic Cages - PMC \[pmc.ncbi.nlm.nih.gov\]](#)
- [8. tandfonline.com \[tandfonline.com\]](#)
- [9. merckmillipore.com \[merckmillipore.com\]](#)
- [10. media.cellsignal.com \[media.cellsignal.com\]](#)
- [11. researchgate.net \[researchgate.net\]](#)
- [12. biochem.wustl.edu \[biochem.wustl.edu\]](#)
- [13. Inhibitory effect of caffeic acid on cancer cell proliferation by oxidative mechanism in human HT-1080 fibrosarcoma cell line - PubMed \[pubmed.ncbi.nlm.nih.gov\]](#)
- [14. researchgate.net \[researchgate.net\]](#)
- [15. Fluorescence polarization assays in high-throughput screening and drug discovery: a review - PMC \[pmc.ncbi.nlm.nih.gov\]](#)
- [16. medschool.lsuhs.edu \[medschool.lsuhs.edu\]](#)
- To cite this document: BenchChem. [Technical Support Center: Troubleshooting Caffeic Acid-pYEEIE Kinase Assay Variability]. BenchChem, [2026]. [Online PDF]. Available at:

[<https://www.benchchem.com/product/b12353371/docs#technical-support-center-troubleshooting-caffeic-acid-pyeee-kinase-assay-variability>]

### Disclaimer & Data Validity:

The information provided in this document is for Research Use Only (RUO) and is strictly not intended for diagnostic or therapeutic procedures. While BenchChem strives to provide accurate protocols, we make no warranties, express or implied, regarding the fitness of this product for every specific experimental setup.

**Technical Support:** The protocols provided are for reference purposes. Unsure if this reagent suits your experiment?

**Need Industrial/Bulk Grade?** [Request Custom Synthesis Quote](#)

## BenchChem

Our mission is to be the trusted global source of essential and advanced chemicals, empowering scientists and researchers to drive progress in science and industry.

### Contact

Address: 3281 E Guasti Rd  
Ontario, CA 91761, United States  
Phone: (601) 213-4426  
Email: [info@benchchem.com](mailto:info@benchchem.com)

[Contact our Ph.D. Support Team for a compatibility check](#)