

Matrix Interference in the DTPA Soil Test: An In-depth Technical Guide

Author: BenchChem Technical Support Team. **Date:** December 2025

Compound of Interest

Compound Name: *Hdtpa*

Cat. No.: *B1235155*

[Get Quote](#)

For Researchers, Scientists, and Drug Development Professionals

Abstract

The Diethylenetriaminepentaacetic acid (DTPA) soil test, a cornerstone for assessing the bioavailability of micronutrients such as zinc (Zn), iron (Fe), manganese (Mn), and copper (Cu), is not without its analytical challenges. Matrix interference, stemming from the complex and variable composition of soil extracts, can significantly impact the accuracy and reliability of this vital diagnostic tool. This technical guide provides a comprehensive overview of the core principles of the DTPA soil test, delves into the mechanisms of matrix interference, presents quantitative data on the effects of common interfering ions, and outlines detailed experimental protocols for both the standard DTPA test and methods to mitigate interferences. Particular attention is given to the roles of bicarbonate, phosphate, calcium, magnesium, and dissolved organic matter in altering the extraction and measurement of target micronutrients. Furthermore, this guide offers practical strategies, including the use of internal standards and the method of standard additions, to ensure the integrity of analytical results. Visual representations of interference pathways and experimental workflows are provided to facilitate a deeper understanding of these complex interactions.

Introduction

The DTPA soil test, developed by Lindsay and Norvell in 1978, is a widely adopted method for estimating the plant-available fraction of essential micronutrients in near-neutral and calcareous soils.^{[1][2][3][4]} The test relies on a buffered solution containing DTPA, a chelating

agent that forms stable, soluble complexes with metal ions, thereby mimicking the process of nutrient uptake by plant roots.[3] The accuracy of the DTPA test is paramount for making informed decisions in agriculture, environmental monitoring, and phytoremediation research.

However, the soil matrix is a heterogeneous mixture of minerals, organic matter, and dissolved salts, which can introduce a variety of interfering substances into the DTPA extract. These interferences, collectively known as matrix effects, can artificially suppress or enhance the analytical signal of the target micronutrients, leading to erroneous conclusions. This guide aims to equip researchers and scientists with the knowledge to identify, understand, and mitigate matrix interference in the DTPA soil test.

The DTPA Soil Test: Core Principles and Protocol

The DTPA extraction solution is specifically formulated to assess the labile pool of micronutrients in the soil that is accessible to plants.

Composition of the DTPA Extracting Solution

The standard DTPA extracting solution consists of:

- 0.005 M Diethylenetriaminepentaacetic acid (DTPA): A chelating agent that forms stable, soluble complexes with micronutrient cations.[3]
- 0.01 M Calcium Chloride (CaCl_2): Added to maintain a constant level of soluble calcium, which helps to prevent the dissolution of calcium carbonate (CaCO_3) in calcareous soils and provides a background electrolyte level.[1][4]
- 0.1 M Triethanolamine (TEA): Acts as a buffer to maintain the pH of the solution at a constant 7.3. This pH is crucial as the availability of micronutrients is highly pH-dependent.[3][4]

Standard Experimental Protocol for the DTPA Soil Test

The following protocol is based on the original method developed by Lindsay and Norvell (1978).[1][3][4]

Materials:

- Air-dried soil sample, passed through a 2 mm sieve

- DTPA extracting solution (pH 7.3)
- Extraction flasks (e.g., 125 mL Erlenmeyer flasks)
- Reciprocating shaker
- Filter paper (e.g., Whatman No. 42)
- Collection vials
- Inductively Coupled Plasma-Optical Emission Spectrometer (ICP-OES) or Atomic Absorption Spectrometer (AAS)

Procedure:

- Weigh 10.0 g of the prepared soil sample into an extraction flask.
- Add 20.0 mL of the DTPA extracting solution to the flask. This creates a 1:2 soil-to-solution ratio.
- Secure the flasks on a reciprocating shaker and shake for exactly 2 hours at a constant speed (e.g., 180 cycles per minute).[3]
- Immediately after shaking, filter the suspension through a suitable filter paper.
- Collect the clear filtrate for analysis.
- Analyze the concentration of Zn, Fe, Mn, and Cu in the filtrate using ICP-OES or AAS.
- Prepare calibration standards in the DTPA extracting solution to matrix-match the standards with the samples.[5]

Mechanisms and Quantification of Matrix Interference

Matrix interference in the DTPA soil test can be broadly categorized into two types: extraction-phase interference and analytical-phase interference.

Extraction-Phase Interference

This type of interference occurs during the 2-hour shaking period when components of the soil matrix affect the efficiency of DTPA in extracting the target micronutrients.

In calcareous and alkaline soils, high concentrations of bicarbonate ions can significantly interfere with the DTPA test. The Ammonium Bicarbonate-DTPA (AB-DTPA) soil test, developed by Soltanpour and Schwab, intentionally includes bicarbonate to simultaneously extract macronutrients like phosphorus.^{[6][7][8][9]} However, this addition highlights the potential for interference.

Mechanism:

- **Competition for Metals:** Bicarbonate can form soluble complexes with micronutrients, competing with DTPA.
- **Precipitation:** In the higher pH environment of the AB-DTPA test (pH 7.6), and in soils with high calcium and magnesium, bicarbonate can lead to the precipitation of calcium and magnesium carbonates.^{[6][10]} This co-precipitation can remove micronutrients from the solution, leading to underestimation.

Table 1: Comparison of Micronutrient Extraction by Standard DTPA and AB-DTPA in Different Soil Types (mg/kg)

Soil Type	Extractant	Zn	Cu	Fe	Mn
Inceptisols	DTPA	1.7	-	28.3	31.0
	AB-DTPA	1.1	-	22.7	28.0
Alfisols	DTPA	1.8	-	-	-
	AB-DTPA	1.0	-	-	-
Entisols	DTPA	1.3	-	-	-
	AB-DTPA	0.7	-	-	-

Data compiled from a comparative study which showed that DTPA generally extracts higher amounts of Zn and Mn, while AB-DTPA can extract higher amounts of Cu and Fe in some soil types.[11] The differences highlight the interference potential of bicarbonate.

High levels of phosphate in the soil, often due to excessive fertilization, can also interfere with the extraction of micronutrients.

Mechanism:

- Precipitation: Phosphate can react with micronutrients, particularly zinc and iron, to form insoluble metal phosphates, reducing their availability for chelation by DTPA.

Quantitative data on the direct interference of phosphate on the DTPA extraction process is not readily available in existing literature. Research has focused more on the impact of high soil phosphorus on plant uptake of micronutrients rather than on the analytical test itself.

While CaCl_2 is a component of the DTPA solution, excessively high concentrations of soluble calcium and magnesium in the soil can pose a challenge.

Mechanism:

- Competition with DTPA: Although DTPA has a high affinity for the target micronutrients, very high concentrations of Ca^{2+} and Mg^{2+} can compete for the chelating agent.
- Precipitation in AB-DTPA: As mentioned, in the presence of bicarbonate (in the AB-DTPA test), high levels of Ca^{2+} and Mg^{2+} can lead to carbonate precipitation, which is a significant interference.[6][10]

Dissolved organic matter consists of a complex mixture of organic molecules that can interact with metal ions.

Mechanism:

- Competitive Chelation: DOM contains functional groups that can chelate micronutrients, competing with DTPA and potentially leading to either an underestimation or overestimation of the bioavailable fraction, depending on the solubility and stability of the DOM-metal complexes.[12][13][14]

- Analytical Interference: High levels of DOM can also cause physical interferences in the analytical instrumentation, such as nebulizer clogging in ICP-OES.

Analytical-Phase Interference

This type of interference occurs during the measurement of the micronutrient concentrations in the DTPA extract, typically using ICP-OES or AAS.

Mechanism:

- Spectral Interferences: This occurs when the emission line of a non-target element overlaps with the emission line of the target analyte. For example, iron (Fe) has a complex emission spectrum and can potentially interfere with the determination of other elements like manganese (Mn).[\[15\]](#)
- Non-Spectral (Matrix) Interferences: These are caused by the physical properties of the sample matrix, such as viscosity, surface tension, and total dissolved solids. High salt concentrations can affect the efficiency of nebulization and plasma characteristics in ICP-OES, leading to signal suppression or enhancement.[\[16\]](#)

Mitigation Strategies for Matrix Interference

Several strategies can be employed to minimize or correct for matrix interference in the DTPA soil test.

Method of Standard Additions

This is a powerful technique for correcting for matrix effects, particularly non-spectral interferences.

Experimental Protocol:

- Prepare the DTPA soil extract as described in section 2.2.
- Take several equal aliquots of the soil extract.
- Keep one aliquot as the "unspiked" sample.

- To the other aliquots, add known and increasing concentrations of a standard solution of the analyte(s) of interest.
- Dilute all aliquots to the same final volume with the DTPA extracting solution.
- Analyze all the spiked and unspiked samples using ICP-OES or AAS.
- Plot the measured absorbance or emission intensity against the concentration of the added standard.
- The absolute value of the x-intercept of the resulting calibration curve represents the concentration of the analyte in the original unspiked sample.

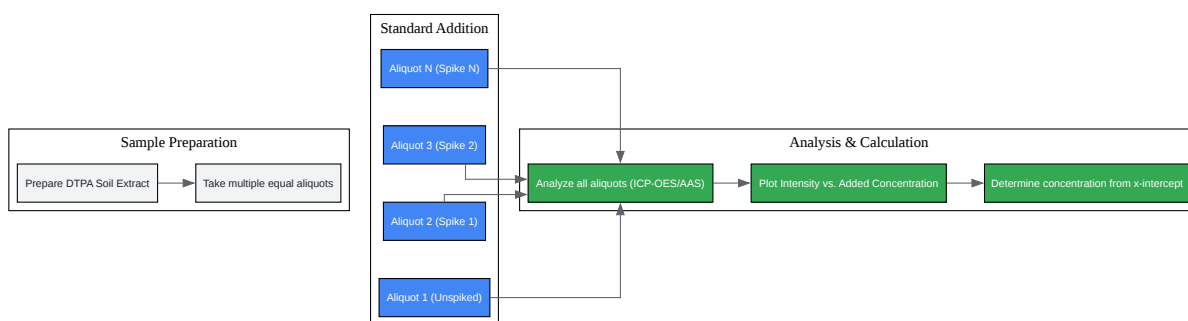

[Click to download full resolution via product page](#)

Caption: Workflow for the Method of Standard Additions.

Use of Internal Standards

An internal standard is an element that is not present in the original sample and is added in a known concentration to all samples, standards, and blanks. It can compensate for variations in sample uptake, nebulization efficiency, and plasma conditions.

Experimental Protocol:

- **Selection of Internal Standard:** Choose an element that is not expected to be present in the soil samples and does not have spectral interferences with the analytes of interest. Common internal standards for ICP-OES include yttrium (Y), scandium (Sc), and indium (In).^{[17][18]}^[19] The internal standard should also have an ionization potential similar to the analytes.
- **Preparation of Internal Standard Stock Solution:** Prepare a concentrated stock solution of the chosen internal standard.
- **Addition of Internal Standard:** Add a small, constant volume of the internal standard stock solution to all calibration standards, blanks, and DTPA soil extracts to achieve a final concentration that provides a stable and reproducible signal.^[17] This can be done manually or through online addition using a mixing tee and a separate channel on the peristaltic pump of the ICP-OES.
- **Analysis:** During the ICP-OES analysis, the instrument software will monitor the intensity of the internal standard and the analytes simultaneously.
- **Correction:** The software will calculate the ratio of the analyte signal to the internal standard signal. This ratio is then used for calibration and quantification, which corrects for fluctuations in the instrument's performance and matrix effects.

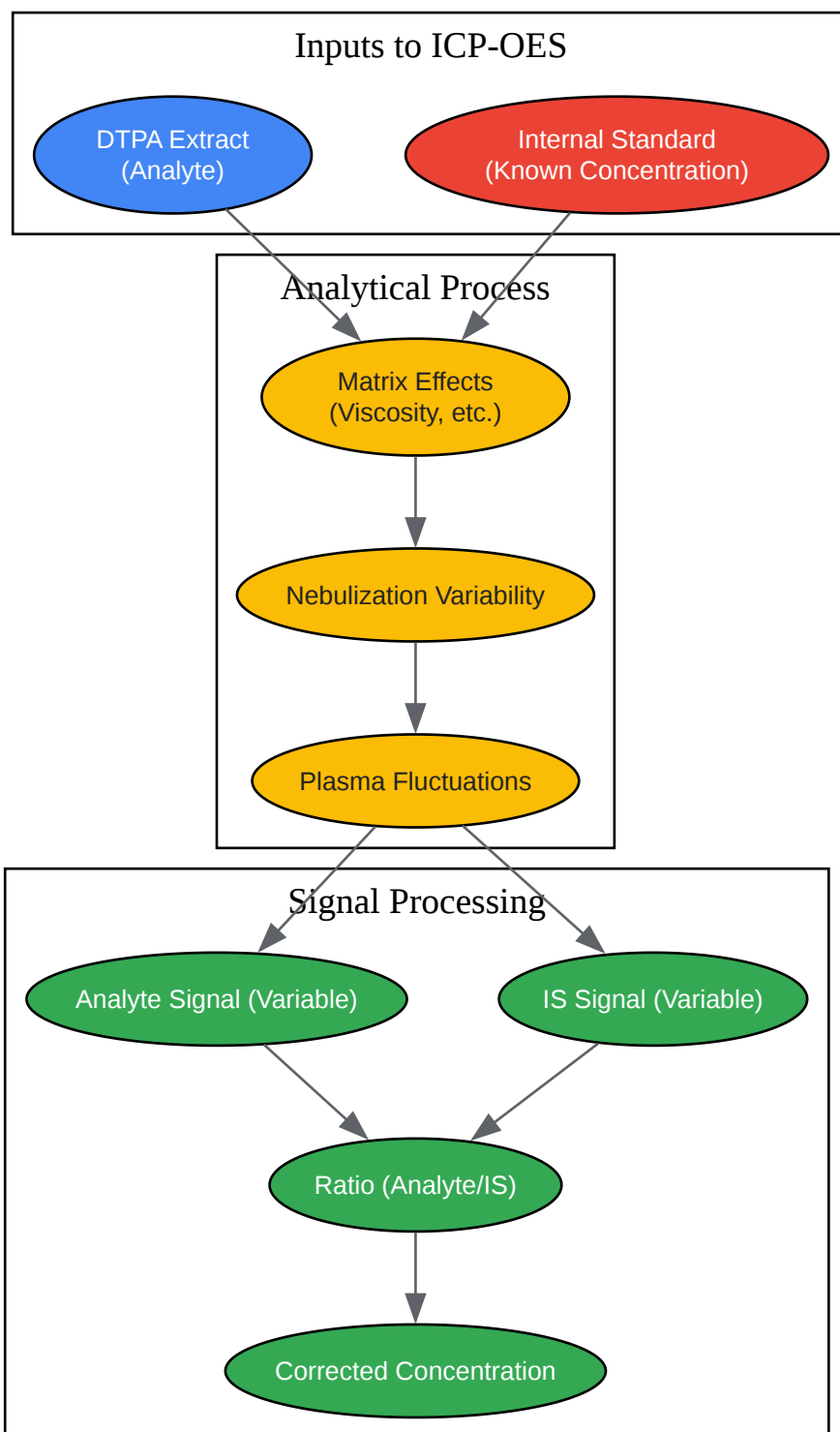

[Click to download full resolution via product page](#)

Caption: Logic of Internal Standard Correction.

Conclusion

While the DTPA soil test is a robust and valuable tool, a thorough understanding of potential matrix interferences is crucial for obtaining accurate and reliable data. For routine analysis of soils with relatively simple matrices, the standard DTPA protocol with matrix-matched standards may be sufficient, especially when using modern analytical instrumentation with effective background correction.[15] However, for research applications, analysis of complex or contaminated soils, or when the highest level of accuracy is required, the implementation of mitigation strategies such as the method of standard additions or the use of internal standards is highly recommended. By carefully considering the potential sources of interference and employing the appropriate analytical techniques, researchers can ensure the integrity of their results and make sound conclusions based on the DTPA soil test.

Need Custom Synthesis?

BenchChem offers custom synthesis for rare earth carbides and specific isotopic labeling.

Email: info@benchchem.com or [Request Quote Online](#).

References

- 1. scispace.com [scispace.com]
- 2. Lindsay, W.L. and Norvell, W.A. (1978) Development of a DTPA Soil Test for Zinc, Iron, Manganese and Copper. Soil Science Society of America Journal, 42, 421-428. - References - Scientific Research Publishing [scirp.org]
- 3. openknowledge.fao.org [openknowledge.fao.org]
- 4. scilit.com [scilit.com]
- 5. agilent.com [agilent.com]
- 6. Use of ammonium bicarbonate DTPA soil test to evaluate elemental availability and toxicity (Journal Article) | OSTI.GOV [osti.gov]
- 7. scribd.com [scribd.com]
- 8. scisoc.confex.com [scisoc.confex.com]
- 9. asrs.us [asrs.us]
- 10. tandfonline.com [tandfonline.com]

- 11. davidpublisher.com [davidpublisher.com]
- 12. researchgate.net [researchgate.net]
- 13. Effect of biochar on transformation of dissolved organic matter and DTPA-extractable Cu and Cd during sediment composting - PubMed [pubmed.ncbi.nlm.nih.gov]
- 14. ars.usda.gov [ars.usda.gov]
- 15. agilent.com [agilent.com]
- 16. m.youtube.com [m.youtube.com]
- 17. spectroscopyonline.com [spectroscopyonline.com]
- 18. ICP-OES Explained: Applications, Setup and Limits | Technology Networks [technologynetworks.com]
- 19. researchgate.net [researchgate.net]
- To cite this document: BenchChem. [Matrix Interference in the DTPA Soil Test: An In-depth Technical Guide]. BenchChem, [2025]. [Online PDF]. Available at: [https://www.benchchem.com/product/b1235155#matrix-interference-in-the-dtpa-soil-test]

Disclaimer & Data Validity:

The information provided in this document is for Research Use Only (RUO) and is strictly not intended for diagnostic or therapeutic procedures. While BenchChem strives to provide accurate protocols, we make no warranties, express or implied, regarding the fitness of this product for every specific experimental setup.

Technical Support: The protocols provided are for reference purposes. Unsure if this reagent suits your experiment? [[Contact our Ph.D. Support Team for a compatibility check](#)]

Need Industrial/Bulk Grade? [Request Custom Synthesis Quote](#)

BenchChem

Our mission is to be the trusted global source of essential and advanced chemicals, empowering scientists and researchers to drive progress in science and industry.

Contact

Address: 3281 E Guasti Rd

Ontario, CA 91761, United States

Phone: (601) 213-4426

Email: info@benchchem.com