

Decoding Cerevisterol: A Comparative Guide to its Mass Spectrometry Fragmentation Patterns

Author: BenchChem Technical Support Team. **Date:** April 2026

Compound of Interest

Compound Name: *Cerevisterol*

Cat. No.: *B1235876*

[Get Quote](#)

For researchers, scientists, and drug development professionals engaged in the analysis of fungal metabolites and other natural products, a comprehensive understanding of a molecule's behavior under mass spectrometry is paramount for its unambiguous identification and characterization. **Cerevisterol** (5 α -ergosta-7,22-diene-3 β ,5,6 β -triol), a tri-hydroxylated ergostane-type sterol first isolated from yeast, presents a unique analytical challenge due to its multiple hydroxyl groups, which significantly influence its fragmentation behavior.[1] This guide provides an in-depth comparison of the predicted mass spectrometry fragmentation patterns of **Cerevisterol** with those of its well-characterized biosynthetic precursor, ergosterol, and the ubiquitous mammalian sterol, cholesterol. By understanding these differences, researchers can develop more robust and specific analytical methods for the detection and quantification of **Cerevisterol** in complex biological matrices.

The Structural Basis of Fragmentation: Cerevisterol in Context

To appreciate the nuances of their fragmentation patterns, it is essential to first consider the structural similarities and differences between **Cerevisterol**, ergosterol, and cholesterol.

- **Cerevisterol** (C₂₈H₄₆O₃, Molar Mass: 430.67 g/mol): Possesses a Δ 7,22-diene system characteristic of many fungal sterols.[1][2] Its defining feature is the presence of three hydroxyl groups at the C-3, C-5, and C-6 positions.[1][2]
- Ergosterol (C₂₈H₄₄O, Molar Mass: 396.65 g/mol): The biosynthetic precursor to **Cerevisterol**, it shares the same carbon skeleton and Δ 7,22-diene system but has only a single hydroxyl group at the C-3 position and an additional double bond at C-5.
- Cholesterol (C₂₇H₄₆O, Molar Mass: 386.65 g/mol): A key sterol in mammalian systems, it has a single hydroxyl group at C-3 and a double bond at the C-5 position.

The presence and location of these functional groups, particularly the hydroxyl moieties and double bonds, are the primary drivers of the distinct fragmentation pathways observed in mass spectrometry.

Comparative Fragmentation Analysis: Ionization-Dependent Pathways

The choice of ionization technique is critical in determining the nature and extent of fragmentation. Here, we compare the expected fragmentation of **Cerevisterol** with ergosterol and cholesterol under two common ionization methods: Atmospheric Pressure Chemical Ionization (APCI) and Electrospray Ionization (ESI), which are frequently coupled with liquid chromatography (LC-MS).

Atmospheric Pressure Chemical Ionization (APCI-MS)

APCI is a moderately "soft" ionization technique that is well-suited for the analysis of less polar compounds like sterols.[3] It typically induces dehydration, providing a prominent pseudomolecular ion corresponding to the loss of water.

Cerevisterol (Predicted APCI Fragmentation):

Due to its three hydroxyl groups, **Cerevisterol** is expected to undergo sequential water losses. The most abundant precursor ion would likely be the result of a single dehydration, $[M+H-H_2O]^+$ at m/z 413.3. Subsequent losses of water molecules would yield ions at m/z 395.3 ($[M+H-2H_2O]^+$) and m/z 377.3 ($[M+H-3H_2O]^+$). The fully dehydrated ion at m/z 377.3 is

structurally analogous to the protonated and dehydrated ergosterol, suggesting that some of their subsequent fragmentation pathways will be similar.

Ergosterol and Cholesterol (Established APCI Fragmentation):

Both ergosterol and cholesterol, with their single hydroxyl group, readily lose water to form abundant $[M+H-H_2O]^+$ ions at m/z 379.3 and m/z 369.3, respectively.[4][5] These dehydrated ions are often the base peaks in their respective spectra and serve as the precursor ions for tandem MS (MS/MS) experiments.

Table 1: Comparison of Key Precursor Ions in APCI-MS

Compound	Molecular Formula	$[M+H]^+$ (Expected)	Primary Precursor Ion(s) (Dehydrated)
Cerevisterol	$C_{28}H_{46}O_3$	431.3	m/z 413.3, 395.3, 377.3
Ergosterol	$C_{28}H_{44}O$	397.3	m/z 379.3
Cholesterol	$C_{27}H_{46}O$	387.3	m/z 369.3

Tandem Mass Spectrometry (MS/MS) Fragmentation

Collision-induced dissociation (CID) of the dehydrated precursor ions reveals structurally informative product ions.

Predicted MS/MS Fragmentation of **Cerevisterol** ($[M+H-3H_2O]^+$ at m/z 377.3):

The fragmentation of the fully dehydrated **Cerevisterol** ion is predicted to mirror that of the dehydrated ergosterol ion due to their similar ergostatriene core. Key fragmentations would involve:

- Side-chain cleavage: Loss of the C_8H_{15} side chain, leading to a fragment around m/z 271.
- Ring cleavages: Characteristic cleavages of the sterol ring system, particularly around the C and D rings, would produce a series of smaller fragment ions. Common fragments observed in sterols include those at m/z 147 and 161.[6]

Established MS/MS Fragmentation of Ergosterol and Cholesterol:

The MS/MS spectra of dehydrated ergosterol (m/z 379.3) and cholesterol (m/z 369.3) are well-documented.[4][7][8]

- Ergosterol: Shows characteristic fragments arising from the cleavage of the unsaturated side chain and the di-unsaturated ring system. A notable fragment is often observed at m/z 69.[9]
- Cholesterol: Fragmentation of the dehydrated ion (m/z 369.3) produces diagnostic ions at m/z 161 and 147, resulting from cleavages within the C and D rings.[4][6]

Table 2: Comparative MS/MS Fragmentation of Dehydrated Precursor Ions

Precursor Ion (m/z)	Compound	Key Diagnostic Product Ions (m/z)	Inferred Fragmentation Pathway
377.3 (Predicted)	Cerevisterol	~271, 161, 147	Side-chain loss, C/D ring cleavage
379.3	Ergosterol	69, various ring fragments	Side-chain and ring system cleavages
369.3	Cholesterol	161, 147	C/D ring cleavage

Experimental Protocols

Sample Preparation and Extraction

A robust sample preparation protocol is crucial for accurate sterol analysis. The following is a general workflow adaptable for various fungal or biological matrices.

- Homogenization: Homogenize the sample in a suitable solvent, such as a chloroform/methanol mixture.
- Lipid Extraction: Perform a liquid-liquid extraction (e.g., modified Bligh-Dyer method) to isolate the lipid fraction.[10]

- Solid-Phase Extraction (SPE): Clean up the lipid extract using a silica-based SPE column to remove interfering compounds. Elute the sterol fraction with a solvent of appropriate polarity. [\[10\]](#)
- Solvent Evaporation and Reconstitution: Evaporate the solvent under a stream of nitrogen and reconstitute the sample in a mobile phase-compatible solvent for LC-MS analysis. [\[10\]](#)

Liquid Chromatography-Tandem Mass Spectrometry (LC-MS/MS)

The following parameters provide a starting point for the analysis of **Cerevisterol** and related sterols.

- LC Column: A C18 reversed-phase column is typically used for sterol separation. [\[11\]](#)
- Mobile Phase: A gradient of methanol or acetonitrile with a small amount of formic acid in water is commonly employed. [\[11\]](#)
- Ionization Source: APCI or ESI in positive ion mode. For hydroxylated steroids like **Cerevisterol**, ESI can also be effective, though it may produce more complex adduction patterns. [\[12\]](#)
- MS/MS Analysis: Use Multiple Reaction Monitoring (MRM) for targeted quantification, selecting the appropriate precursor-to-product ion transitions for each sterol. [\[9\]](#)

Visualizing the Fragmentation Pathways

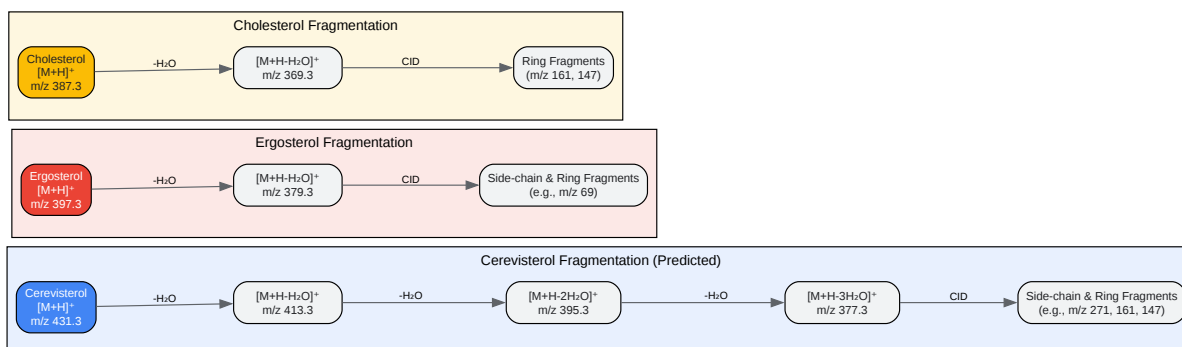

[Click to download full resolution via product page](#)

Caption: Comparative fragmentation pathways of sterols.

Conclusion

The mass spectrometric fragmentation of **Cerevisterol** is predicted to be dominated by the sequential loss of its three hydroxyl groups as water molecules, particularly under APCI conditions. The resulting fully dehydrated ion shares a common structural core with dehydrated ergosterol, leading to some overlap in their subsequent MS/MS fragmentation patterns. However, the initial multi-dehydration pathway of **Cerevisterol** provides a clear diagnostic feature to distinguish it from its mono-hydroxylated counterparts, ergosterol and cholesterol. By leveraging this understanding and employing optimized LC-MS/MS methods, researchers can confidently identify and characterize **Cerevisterol** in complex samples, advancing our knowledge of fungal biochemistry and its potential applications.

References

- Wyllie, S. G., & Djerassi, C. (1968). Mass spectrometry in structural and stereochemical problems. CXLVI. Mass spectrometric fragmentations typical of sterols with unsaturated side chains. *The Journal of Organic Chemistry*, 33(1), 305-313. [\[Link\]](#)
- Passarelli, M. K., Winograd, N., & Ewing, A. G. (2012). MS/MS methodology to improve sub-cellular mapping of cholesterol using ToF-SIMS. *Surface and Interface Analysis*, 44(8), 1145-1149. [\[Link\]](#)
- Zand, A., Lorenz, M., & Volmer, D. A. (2019). Major MS/MS fragments of lanosterol, T-MAS, zymosterol and ergosterol and proposed CID fragmentation pathways. *Rapid Communications in Mass Spectrometry*, 33(S2), 39-47. [\[Link\]](#)
- Jiang, X., et al. (2020). Diagnostic Fragmentations of Animal and Fungal Sterols/Stanols Obtained by APCI–Tandem Mass Spectrometry: A Route Towards Unknown Free Sterol Identification. *Metabolites*, 10(10), 405. [\[Link\]](#)
- Hubert, J., et al. (2020). Detection of ergosterol using liquid chromatography/electrospray ionization mass spectrometry: Investigation of unusual in-source reactions. *Rapid Communications in Mass Spectrometry*, 34(S3), e8753. [\[Link\]](#)
- Gaudin, M., et al. (2020). Detection of ergosterol using liquid chromatography/electrospray ionization mass spectrometry: Investigation of unusual in-source reactions. *PubMed*, 32608465. [\[Link\]](#)
- Sandhoff, R., et al. (1999). Determination of cholesterol at the low picomole level by nano-electrospray ionization tandem mass spectrometry. *Journal of Lipid Research*, 40(1), 126-132. [\[Link\]](#)
- Giera, M., et al. (2012). LC-MS/MS analysis of cholesterol. *ResearchGate*. [\[Link\]](#)
- Kusebauch, B., Bader, S., & Carl, S. (2020). Full scan mass spectrum of ergosterol. *ResearchGate*. [\[Link\]](#)
- Sidorov, I., et al. (2023). In-Source Fragmentation Annotation in Sterol Mass Spectrometry Imaging. *Analytical Chemistry*, 95(1), 359-366. [\[Link\]](#)

- PubChem. (n.d.). **Cerevisterol**. National Center for Biotechnology Information. Retrieved February 27, 2026, from [\[Link\]](#)
- Griffiths, W. J., & Wang, Y. (2019). A new derivative for oxosteroid analysis by mass spectrometry. *Journal of Steroid Biochemistry and Molecular Biology*, 190, 198-212. [\[Link\]](#)
- Higashi, T., & Shimada, K. (2018). ESI-MS spectra of the 3-OH steroids. ResearchGate. [\[Link\]](#)
- Headley, J. V., Peru, K. M., & McMartin, D. W. (2002). Analysis of ergosterol by LC/MS/MS and comparative study with other analytical techniques. *Journal of the American Society for Mass Spectrometry*, 13(11), 1336-1342. [\[Link\]](#)
- Münger, L. H., et al. (2018). UPLC-MS/MS Based Identification of Dietary Steryl Glucosides by Investigation of Corresponding Free Sterols. *Frontiers in Plant Science*, 9, 1215. [\[Link\]](#)
- Rozès, N., et al. (2019). Fungal Sterol Analyses by Gas Chromatography–Mass Spectrometry Using Different Derivatives. In *Fungal Metabolites* (pp. 203-220). Humana, New York, NY. [\[Link\]](#)
- Wikipedia. (2023, December 1). **Cerevisterol**. In Wikipedia. [\[Link\]](#)
- LIPID MAPS. (2007, October 11). Sterols Mass Spectra Protocol. [\[Link\]](#)
- LIPID MAPS. (2007, July 6). Sterols Mass Spectra Protocol. [\[Link\]](#)
- Headley, J. V., Peru, K. M., & McMartin, D. W. (2002). Analysis of Ergosterol by LC/MS/MS and Comparative Study with Other Analytical. ResearchGate. [\[Link\]](#)
- MassBank. (n.d.). Home. Retrieved February 27, 2026, from [\[Link\]](#)
- ResearchGate. (n.d.). Structure of ergosterol confirmed by ¹³C, ¹H RMN and GC-EI-MS. [\[Link\]](#)
- LabX. (n.d.). Mastering Atmospheric Pressure Chemical Ionization (APCI) in Mass Spectrometry. Retrieved February 27, 2026, from [\[Link\]](#)

- Taylor, R. L., et al. (2022). Multi-steroid profiling by uPLC-MS/MS with post-column infusion of ammonium fluoride. *Journal of Mass Spectrometry and Advances in the Clinical Lab*, 25, 25-33. [\[Link\]](#)
- Wang, J., et al. (2020). LC–MS/MS with ESI and APCI Sources for Meeting California Cannabis Pesticide and Mycotoxin Residue Regulatory Requirements. *Cannabis Science and Technology*, 3(8), 34-44. [\[Link\]](#)
- MassBank. (n.d.). Home. Retrieved February 27, 2026, from [\[Link\]](#)
- METLIN. (n.d.). A Technology Platform for Identifying Knowns and Unknowns. Retrieved February 27, 2026, from [\[Link\]](#)
- Database Commons. (2018, February 10). METLIN. [\[Link\]](#)
- Waters Corporation. (n.d.). Simultaneous Quantification of Chemically Diverse Compounds Using ESCi Multi-Mode Ionization with ACQUITY UPLC and Quattro Premier. [\[Link\]](#)
- Scripps Research. (n.d.). METLIN. Retrieved February 27, 2026, from [\[Link\]](#)
- Agilent Technologies. (2008). Molecular Formula and METLIN Personal Metabolite Database Matching Applied to the Identification of Compounds Generated by LC/TOF MS. [\[Link\]](#)
- LCGC International. (2020, August 13). Novel LC–MS/MS Method with a Dual ESI and APCI Ion Source for Analysis of California-Regulated Pesticides and Mycotoxins in Medium-Chain Triglyceride (MCT) Oil Cannabis Tinctures. [\[Link\]](#)
- Pozo, O. J., et al. (2018). Mass spectral fragmentation analyses of isotopically labelled hydroxy steroids using gas chromatography/electron ionization low-resolution mass spectrometry: A practical approach. *Journal of Mass Spectrometry*, 53(10), 995-1008. [\[Link\]](#)
- Guijas, C., et al. (2018). METLIN MS2 molecular standards database: a broad chemical and biological resource. *Nature Methods*, 15(9), 692-694. [\[Link\]](#)
- Agilent Technologies. (n.d.). Analysis of Multiclass Steroids in Serum Using Agilent Ultivo Triple Quadrupole LC/MS. [\[Link\]](#)

- NIST. (n.d.). γ -Sitosterol. In NIST Chemistry WebBook. [[Link](#)]
- MassBank. (2007, August 1). chemontid:0000147. [[Link](#)]
- NIST. (n.d.). Ergosterol. In NIST Chemistry WebBook. [[Link](#)]
- NIST. (n.d.). Cholesterol. In NIST Chemistry WebBook. [[Link](#)]
- NIST. (n.d.). Campesterol, TMS derivative. In NIST Chemistry WebBook. [[Link](#)]

Need Custom Synthesis?

BenchChem offers custom synthesis for rare earth carbides and specific isotopic labeling.

Email: info@benchchem.com or [Request Quote Online](#).

Sources

1. Cerevisterol - Wikipedia [en.wikipedia.org]
2. CEREVISTEROL | 516-37-0 [chemicalbook.com]
3. Mastering Atmospheric Pressure Chemical Ionization (APCI) in Mass Spectrometry [labx.com]
4. researchgate.net [researchgate.net]
5. researchgate.net [researchgate.net]
6. MS/MS Methodology to Improve Sub-Cellular Mapping of Cholesterol Using ToF-SIMS - PMC [pmc.ncbi.nlm.nih.gov]
7. researchgate.net [researchgate.net]
8. mdpi.com [mdpi.com]
9. researchgate.net [researchgate.net]
10. lipidmaps.org [lipidmaps.org]
11. Frontiers | UPLC-MS/MS Based Identification of Dietary Steryl Glucosides by Investigation of Corresponding Free Sterols [frontiersin.org]
12. Detection of ergosterol using liquid chromatography/electrospray ionization mass spectrometry: Investigation of unusual in-source reactions - PubMed [pubmed.ncbi.nlm.nih.gov]

- To cite this document: BenchChem. [Decoding Cerevisterol: A Comparative Guide to its Mass Spectrometry Fragmentation Patterns]. BenchChem, [2026]. [Online PDF]. Available at: [<https://www.benchchem.com/product/b1235876/docs#decoding-cerevisterol-a-comparative-guide-to-its-mass-spectrometry-fragmentation-patterns>]

Disclaimer & Data Validity:

The information provided in this document is for Research Use Only (RUO) and is strictly not intended for diagnostic or therapeutic procedures. While BenchChem strives to provide accurate protocols, we make no warranties, express or implied, regarding the fitness of this product for every specific experimental setup.

Technical Support: The protocols provided are for reference purposes. Unsure if this reagent suits your experiment?

Need Industrial/Bulk Grade? [Request Custom Synthesis Quote](#)

BenchChem

Our mission is to be the trusted global source of essential and advanced chemicals, empowering scientists and researchers to drive progress in science and industry.

Contact

Address: 3281 E Guasti Rd

Ontario, CA 91761, United States

Phone: (601) 213-4426

Email: info@benchchem.com

[Contact our Ph.D. Support Team for a compatibility check](#)