

Application Notes & Protocols for In Vitro Evaluation of Pyrazole-Based Compounds

Author: BenchChem Technical Support Team. **Date:** May 2026

Compound of Interest

Compound Name: 2-CHLORO-N-(1-METHYL-1H-PYRAZOL-3-YL)ACETAMIDE

CAS No.: 957510-87-1

Cat. No.: B1235561

[Get Quote](#)

Introduction: The Pyrazole Scaffold as a Privileged Core in Drug Discovery

The pyrazole nucleus, a five-membered aromatic heterocycle with two adjacent nitrogen atoms, has firmly established itself as a "privileged scaffold" in modern medicinal chemistry.^{[1][2]} Its remarkable versatility, synthetic accessibility, and metabolic stability have made it a cornerstone in the design of numerous therapeutic agents.^{[1][3]} This is evidenced by the significant number of FDA-approved drugs incorporating this moiety, which target a wide array of diseases.^{[1][4]} Pyrazole derivatives are particularly prominent in oncology, where they form the core of many targeted protein kinase inhibitors (PKIs), including treatments for various cancers and inflammatory conditions.^{[4][5]}

This technical guide provides researchers, scientists, and drug development professionals with a comprehensive overview of essential in vitro assays for the characterization of novel pyrazole-based compounds. Moving beyond simple procedural lists, this document delves into the causality behind experimental choices, outlines self-validating protocols, and offers insights to empower robust and reproducible data generation. We will explore a logical cascade of

assays, beginning with direct target engagement in biochemical assays, progressing to the elucidation of cellular effects, and concluding with critical early-stage profiling for drug-like properties.

Section 1: Biochemical Assays — Quantifying Direct Target Engagement

The initial step in characterizing a new compound is to confirm and quantify its interaction with the intended purified molecular target. Biochemical assays provide a clean, cell-free system to determine intrinsic potency (e.g., IC_{50} , K_i) and can be configured for high-throughput screening (HTS).

Protein Kinase Inhibition Assays

A primary application for pyrazole compounds is the inhibition of protein kinases, which play pivotal roles in cellular signaling pathways often dysregulated in cancer.^{[4][5]} Many pyrazole-based inhibitors are ATP-competitive, binding to the kinase's active site and preventing the phosphorylation of substrate proteins.

Causality & Experimental Insight: The choice of assay format is critical. Luminescence-based assays, such as the ADP-Glo™ Kinase Assay, are favored in drug discovery for their high sensitivity, broad dynamic range, and resistance to compound interference. This assay quantifies the amount of ADP produced during the kinase reaction; a potent inhibitor will result in less ADP production and a lower luminescent signal. This provides a direct measure of the compound's ability to inhibit the enzyme's catalytic activity.

Protocol: ADP-Glo™ Kinase Assay for IC_{50} Determination

This protocol describes a method to determine the half-maximal inhibitory concentration (IC_{50}) of a pyrazole-based compound against a target kinase.

- Compound Preparation:
 - Prepare a 10 mM stock solution of the pyrazole compound in 100% DMSO.
 - Perform serial dilutions in DMSO to create a concentration gradient (e.g., 10-point, 3-fold dilutions). Subsequently, dilute these into the appropriate kinase reaction buffer. The final

DMSO concentration in the assay should not exceed 1% to avoid solvent-induced enzyme inhibition.

- Kinase Reaction Setup (96- or 384-well plate):
 - To each well, add 5 μL of the kinase reaction mix containing the target kinase and its specific substrate in kinase buffer.
 - Add 2.5 μL of the serially diluted pyrazole compound or vehicle control (DMSO in buffer).
 - Initiate the kinase reaction by adding 2.5 μL of ATP solution. The final ATP concentration should ideally be at or near the Michaelis-Menten constant (K_m) for the specific kinase to ensure accurate IC_{50} determination for ATP-competitive inhibitors.
 - Incubate the plate at 30°C for 60 minutes. The incubation time should be optimized to ensure the reaction is within the linear range (typically <30% ATP consumption in vehicle control wells).
- ADP Detection:
 - Add 10 μL of ADP-Glo™ Reagent to each well to terminate the kinase reaction and deplete the remaining ATP. Incubate at room temperature for 40 minutes.
 - Add 20 μL of Kinase Detection Reagent to each well. This reagent converts the newly generated ADP into ATP, which then drives a luciferase/luciferin reaction.
 - Incubate at room temperature for 30-60 minutes to allow the luminescent signal to stabilize.
- Data Acquisition and Analysis:
 - Measure luminescence using a plate-reading luminometer.
 - Calculate the percentage of inhibition for each compound concentration relative to the vehicle (0% inhibition) and no-enzyme (100% inhibition) controls.
 - Plot the percent inhibition against the logarithm of the compound concentration and fit the data to a four-parameter logistic equation to determine the IC_{50} value.

Experimental Workflow: Kinase Inhibition Assay

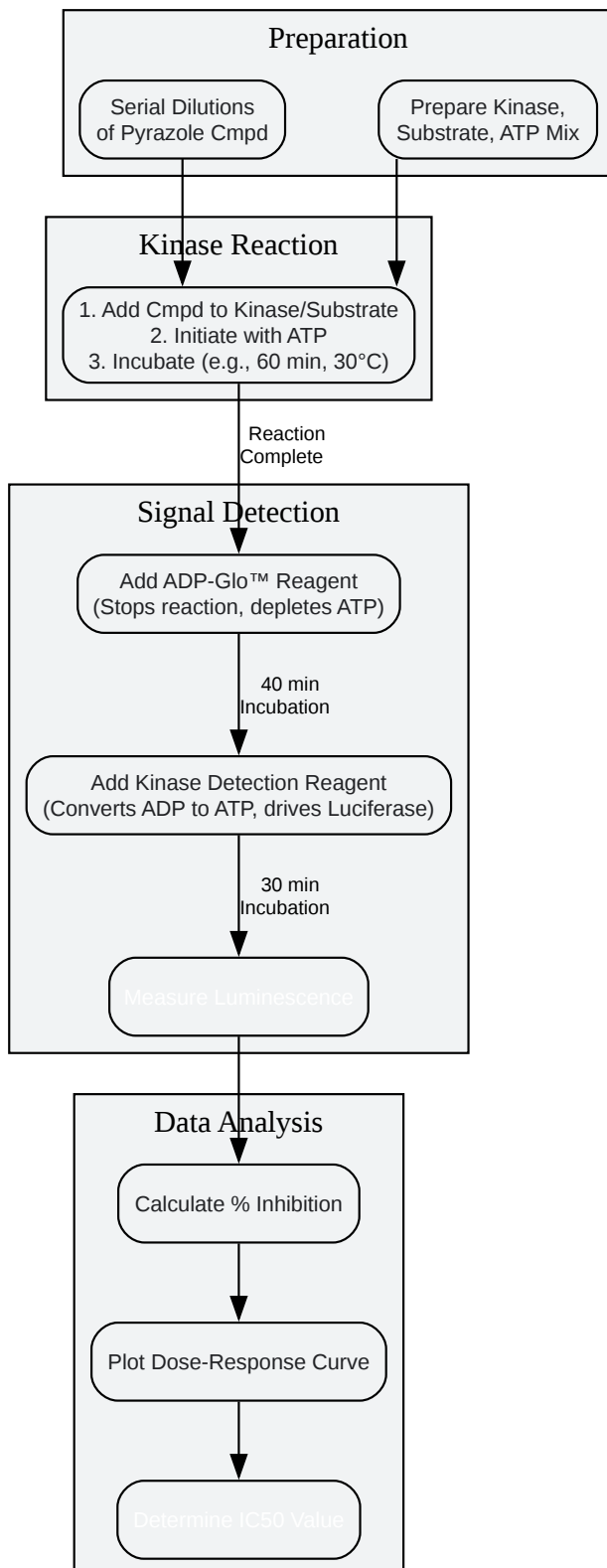

[Click to download full resolution via product page](#)

Caption: Workflow for a luminescence-based kinase inhibition assay.

Data Presentation: Potency of Pyrazole-Based Kinase Inhibitors

Inhibitor	Target Kinase(s)	IC ₅₀ / K _i	Reference
Compound 3f	JAK1, JAK2, JAK3	3.4 nM, 2.2 nM, 3.5 nM	[6]
TK4g	JAK2, JAK3	12.61 nM, 15.80 nM	[7][8]
Ruxolitinib	JAK1, JAK2	~3 nM, ~3 nM	[1][9]
Compound 9	CDK2/cyclin A2	0.96 μM	[10][11]
Compound 15	CDK2	K _i = 0.005 μM	[12]
Afuresertib	Akt1	K _i = 0.08 nM	[5]

Section 2: Cell-Based Assays — Assessing Cellular Phenotypes

While biochemical assays measure intrinsic potency, cell-based assays are essential for confirming that a compound can cross the cell membrane, engage its target in a complex cellular environment, and elicit the desired biological response.

Cell Viability and Cytotoxicity Assays

For anticancer drug discovery, the foundational cell-based assay is one that measures a compound's effect on cell proliferation and viability. The MTT assay is a widely used colorimetric method for this purpose.[1][13]

Causality & Experimental Insight: The MTT assay relies on the activity of mitochondrial NAD(P)H-dependent oxidoreductase enzymes in viable cells to reduce the yellow tetrazolium salt (MTT) into purple formazan crystals.[1] The amount of formazan produced is directly proportional to the number of living, metabolically active cells. This provides a robust readout of a compound's cytostatic (inhibiting growth) or cytotoxic (killing cells) effects. It is crucial to include a vehicle control (e.g., 0.1% DMSO) to account for any solvent effects and to ensure the chosen cell seeding density allows for logarithmic growth during the assay period.[14]

Protocol: MTT Cell Viability Assay

- Cell Seeding:
 - Harvest and count cancer cells from a logarithmic phase culture.
 - Seed the cells into a 96-well flat-bottom plate at a predetermined optimal density (e.g., 3,000-10,000 cells/well) in 100 μ L of complete culture medium.
 - Incubate the plate for 24 hours at 37°C in a 5% CO₂ incubator to allow cells to adhere.
- Compound Treatment:
 - Prepare serial dilutions of the pyrazole compound in culture medium from a DMSO stock.
 - Remove the old medium from the wells and add 100 μ L of medium containing the desired final concentrations of the compound or vehicle control.
 - Incubate for the desired exposure time (e.g., 48 or 72 hours).
- MTT Incubation:
 - Add 20 μ L of MTT solution (5 mg/mL in PBS) to each well.
 - Incubate the plate for 3-4 hours at 37°C, allowing the formazan crystals to form. Visually inspect for the formation of purple precipitates.
- Formazan Solubilization:
 - Carefully remove the medium from each well.
 - Add 150 μ L of a solubilization solution (e.g., DMSO or 10% SDS in 0.01 M HCl) to each well to dissolve the formazan crystals.[\[13\]](#)
 - Gently pipette to ensure complete dissolution and a homogenous colored solution.
- Data Acquisition and Analysis:

- Measure the absorbance of each well at a wavelength of 570-595 nm using a microplate spectrophotometer.
- Calculate the percentage of cell viability relative to the vehicle-treated control cells.
- Determine the IC₅₀ or GI₅₀ (concentration causing 50% inhibition of growth) value by plotting the data as described for the kinase assay.

Data Presentation: Cytotoxicity of Pyrazole Compounds in Cancer Cell Lines

Compound ID	Cancer Cell Line	Cancer Type	IC ₅₀ / GI ₅₀ (μM)	Reference
Compound 7a	HepG2	Liver Carcinoma	6.1 ± 1.9	[15][16]
Compound 7b	HepG2	Liver Carcinoma	7.9 ± 1.9	[15][16]
Compound 11b	HEL	Erythroleukemia	Submicromolar	[6]
Compound 4	NCI-60 Panel (Mean)	Various	GI ₅₀ = 3.81	[10]
Compound 6c	SK-MEL-28	Melanoma	3.46	[17]

Cell Cycle Analysis

For compounds that inhibit cell proliferation, it is critical to understand the mechanism. Many pyrazole-based kinase inhibitors, particularly those targeting Cyclin-Dependent Kinases (CDKs), cause cells to arrest at specific phases of the cell cycle.[10][18]

Causality & Experimental Insight: Cell cycle analysis by flow cytometry utilizes a fluorescent dye, such as Propidium Iodide (PI), that intercalates with DNA. The amount of fluorescence emitted by a cell is directly proportional to its DNA content. This allows for the quantification of cells in different phases: G0/G1 (2n DNA content), S (intermediate DNA content), and G2/M (4n DNA content).[14] A compound that blocks the G1/S transition, for example, will cause an accumulation of cells in the G1 peak and a reduction in the S and G2/M peaks compared to an untreated control population.

Signaling Pathway: CDK2 and G1/S Cell Cycle Transition

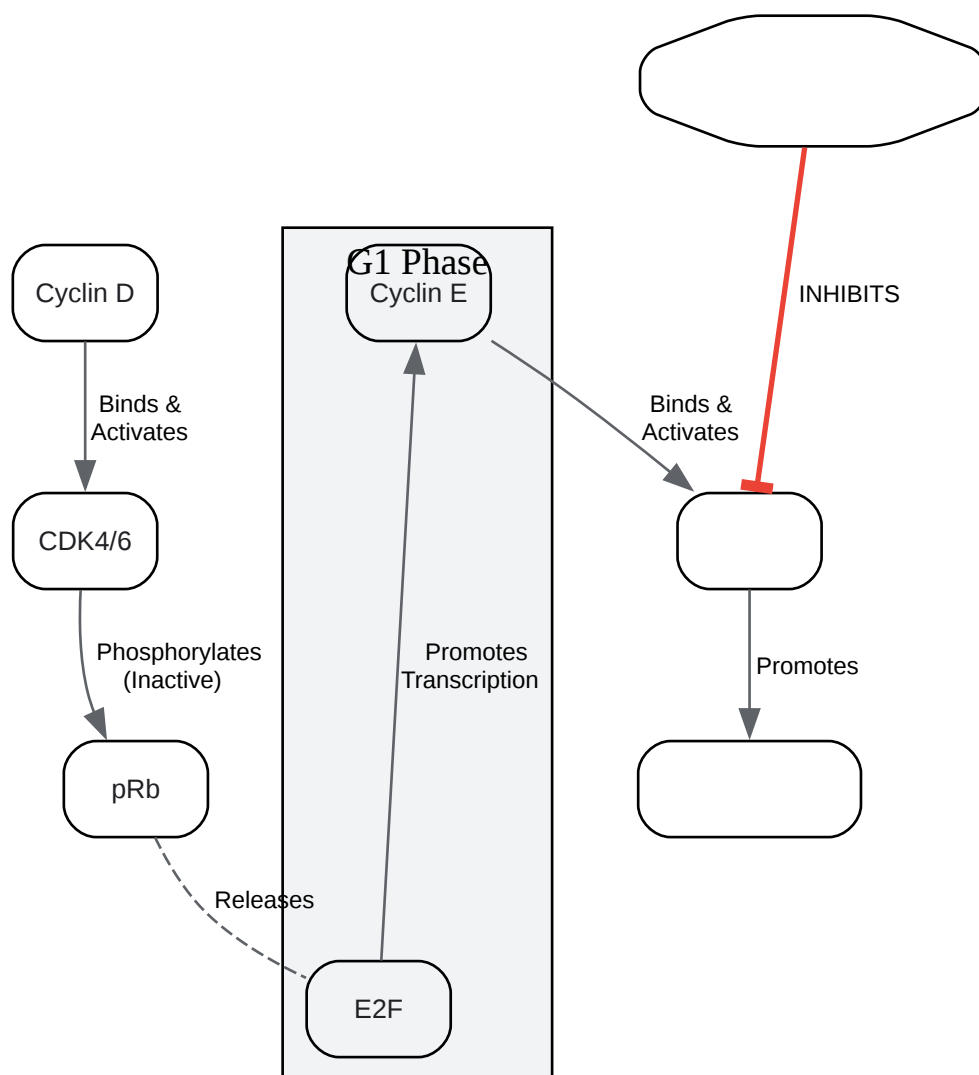

[Click to download full resolution via product page](#)

Caption: Pyrazole-based CDK2 inhibitors block the G1/S transition.

Protocol: Cell Cycle Analysis via Propidium Iodide Staining

- Cell Seeding and Treatment: Seed cells in 6-well plates and treat with the pyrazole compound at relevant concentrations (e.g., 1x and 5x IC₅₀) for a defined period (e.g., 24 hours). Include a vehicle control.
- Cell Harvesting: Collect both adherent and floating cells to ensure apoptotic cells are not lost. Wash with ice-cold PBS.

- **Fixation:** Resuspend the cell pellet in 500 μ L of ice-cold PBS. While vortexing gently, add 4.5 mL of ice-cold 70% ethanol dropwise to fix the cells. Store at -20°C for at least 2 hours (or up to several weeks).
- **Staining:** Centrifuge the fixed cells and wash with PBS. Resuspend the cell pellet in 500 μ L of PI staining solution (containing PI and RNase A). Incubate in the dark at room temperature for 30 minutes.
- **Flow Cytometry:** Analyze the samples on a flow cytometer, acquiring data for at least 10,000 events per sample. Use software (e.g., FlowJo, FCS Express) to gate on single cells and model the DNA content histogram to quantify the percentage of cells in G0/G1, S, and G2/M phases.

Section 3: Early ADME & Secondary Assays

Promising compounds must be profiled for their drug-like properties. In vitro Absorption, Distribution, Metabolism, and Excretion (ADME) assays are critical for identifying potential liabilities early in the discovery process.^[19]

Causality & Experimental Insight: A compound is useless if it cannot reach its target in the body. Microsomal stability assays predict metabolic clearance by the liver, a primary route of drug elimination. Compounds are incubated with liver microsomes (which contain key drug-metabolizing enzymes like Cytochrome P450s), and the disappearance of the parent compound is monitored over time.^[19] A compound with high clearance in this assay may have a short half-life in vivo. The Parallel Artificial Membrane Permeability Assay (PAMPA) predicts passive diffusion across the gut wall, a key step in oral absorption.^[19] A compound with low permeability may be poorly bioavailable.

Overview of Key In Vitro ADME Assays

Assay	Purpose	Principle
Metabolic Stability	Predicts metabolic clearance in the liver.	Incubate compound with liver microsomes and NADPH (a cofactor). Measure the percentage of compound remaining over time via LC-MS/MS.[19]
PAMPA	Predicts passive gut absorption.	A donor plate contains the compound in buffer. An acceptor plate is separated by an artificial membrane coated in lipid. Measure the amount of compound that crosses the membrane.[19]
Plasma Protein Binding	Determines the fraction of compound bound to plasma proteins.	Use equilibrium dialysis or ultrafiltration to separate bound from unbound compound. Only the unbound fraction is pharmacologically active.[19]
CYP450 Inhibition	Identifies potential for drug-drug interactions.	Incubate the compound with specific CYP450 isoforms and a probe substrate. Measure the inhibition of the probe's metabolism.[18]

Conclusion

The pyrazole scaffold is a rich source of novel drug candidates, particularly in the realm of kinase inhibition.[2][4] A systematic and mechanistically driven in vitro assay cascade is paramount for successfully identifying and optimizing these compounds. By progressing from high-throughput biochemical screens that confirm direct target potency to a suite of cell-based assays that elucidate the desired phenotype (e.g., cytotoxicity, cell cycle arrest), researchers can build a comprehensive profile of their compounds.[15][16] Integrating early ADME and toxicology profiling ensures that resources are focused on candidates with the highest

probability of success in downstream preclinical and clinical development. This integrated approach, grounded in scientific integrity, is essential for harnessing the full therapeutic potential of this remarkable heterocyclic system.[1]

References

- Fancelli, D., et al. (2023). The Importance of the Pyrazole Scaffold in the Design of Protein Kinases Inhibitors as Targeted Anticancer Therapies. MDPI. Available at: [\[Link\]](#)
- Zhang, X., et al. (2018). Design, Synthesis, and Antitumor Evaluation of 4-Amino-(1H)-pyrazole Derivatives as JAKs Inhibitors. National Institutes of Health (PMC). Available at: [\[Link\]](#)
- Brough, P. A., et al. (2006). Discovery and Development of Pyrazole-Scaffold Hsp90 Inhibitors. Current Topics in Medicinal Chemistry. Available at: [\[Link\]](#)
- Alam, M. J., et al. (2023). Pyrazole: an emerging privileged scaffold in drug discovery. PubMed Central. Available at: [\[Link\]](#)
- Alam, M. J., et al. (2023). Pyrazole: an Emerging Privileged Scaffold in Drug Discovery. Taylor & Francis Online. Available at: [\[Link\]](#)
- Abdel-Maksoud, M. S., et al. (2024). Discovery of pyrazole-based analogs as CDK2 inhibitors with apoptotic-inducing activity: design, synthesis and molecular dynamics study. RSC Publishing. Available at: [\[Link\]](#)
- Wikipedia. (n.d.). Celecoxib. Wikipedia. Available at: [\[Link\]](#)
- Sosič, I., et al. (2022). Pharmacophore-Based Virtual Screening and Experimental Validation of Pyrazolone-Derived Inhibitors toward Janus Kinases. National Institutes of Health. Available at: [\[Link\]](#)
- Sosič, I., et al. (2022). Pharmacophore-Based Virtual Screening and Experimental Validation of Pyrazolone-Derived Inhibitors toward Janus Kinases. ACS Omega. Available at: [\[Link\]](#)
- Mandal, A. (2018). Celebrex (Celecoxib) Pharmacology. News-Medical.Net. Available at: [\[Link\]](#)

- Abdel-Maksoud, M. S., et al. (2024). Discovery of pyrazole-based analogs as CDK2 inhibitors with apoptotic-inducing activity: design, synthesis and molecular dynamics study. RSC Publishing. Available at: [\[Link\]](#)
- Patsnap Synapse. (2024). What is the mechanism of Celecoxib?. Patsnap Synapse. Available at: [\[Link\]](#)
- El-Sayed, N. N. E., et al. (2021). Design, Synthesis, Anticancer Evaluation, Enzymatic Assays, and a Molecular Modeling Study of Novel Pyrazole–Indole Hybrids. ACS Publications. Available at: [\[Link\]](#)
- Mphahlele, M. J., et al. (2025). Derivatives of Pyrazole-Based Compounds as Prospective Cancer Agents. ACS Omega. Available at: [\[Link\]](#)
- El-Sayed, N. N. E., et al. (2021). Design, Synthesis, Anticancer Evaluation, Enzymatic Assays, and a Molecular Modeling Study of Novel Pyrazole–Indole Hybrids. National Institutes of Health. Available at: [\[Link\]](#)
- Mphahlele, M. J., et al. (2023). Synthesis, in silico modelling, and in vitro biological evaluation of substituted pyrazole derivatives as potential anti-skin cancer, anti-tyrosinase, and antioxidant agents. PubMed Central. Available at: [\[Link\]](#)
- ClinPGx. (n.d.). Celecoxib Pathway, Pharmacodynamics. PharmGKB. Available at: [\[Link\]](#)
- Lang, J.-J., et al. (2023). Discovery of C-5 Pyrazole-Substituted Pyrrolopyridine Derivatives as Potent and Selective Inhibitors for Janus Kinase 1. Journal of Medicinal Chemistry. Available at: [\[Link\]](#)
- Al-Obaid, A. M., et al. (2023). Discovery of N,4-Di(1H-pyrazol-4-yl)pyrimidin-2-amine-Derived CDK2 Inhibitors as Potential Anticancer Agents: Design, Synthesis, and Evaluation. MDPI. Available at: [\[Link\]](#)
- Ghorab, M. M., et al. (2022). Advances in Pyrazole Based Scaffold as Cyclin-dependent Kinase 2 Inhibitors for the Treatment of Cancer. Bentham Science Publishers. Available at: [\[Link\]](#)

- El-Gohary, N. S., et al. (2025). Eco-friendly synthesis of novel pyrazole derivatives and their anticancer and CDK2 inhibitory activities. RSC Publishing. Available at: [\[Link\]](#)
- Asati, V., et al. (2016). Current status of pyrazole and its biological activities. PubMed Central. Available at: [\[Link\]](#)
- Siddiqui, S., et al. (2017). Synthesis and Evaluation of Novel Pyrazole Ethandiamide Compounds as Inhibitors of Human THP-1 Monocytic Cell Neurotoxicity. PubMed Central. Available at: [\[Link\]](#)
- Tebbji, K., et al. (2011). Synthesis and enzyme inhibitory activities of some new pyrazole-based heterocyclic compounds. ResearchGate. Available at: [\[Link\]](#)
- Abdel-Maksoud, M. S., et al. (2024). Discovery of pyrazole-based analogs as CDK2 inhibitors with apoptotic-inducing activity: design, synthesis and molecular dynamics study. RSC Publishing. Available at: [\[Link\]](#)
- ResearchGate. (n.d.). Structures of pyrazole-based JAK inhibitors and their IC50/Ki values. ResearchGate. Available at: [\[Link\]](#)
- Chalkha, M., et al. (2023). Design, synthesis, characterization, in vitro screening, molecular docking, 3D-QSAR, and ADME-Tox investigations of novel pyrazole derivatives as antimicrobial agents. New Journal of Chemistry (RSC Publishing). Available at: [\[Link\]](#)
- Kamal, A., et al. (2022). Design, synthesis and in vitro cytotoxicity evaluation of indolo-pyrazoles grafted with thiazolidinone as tubulin polymerization inhibitors. PubMed Central. Available at: [\[Link\]](#)
- Al-Abdullah, E. S., et al. (2022). Kinase Inhibitory Activities and Molecular Docking of a Novel Series of Anticancer Pyrazole Derivatives. MDPI. Available at: [\[Link\]](#)
- National Center for Biotechnology Information. (2015). In Vitro and In Vivo Assessment of ADME and PK Properties During Lead Selection and Lead Optimization – Guidelines, Benchmarks and Rules of Thumb. Assay Guidance Manual. Available at: [\[Link\]](#)
- Li, Y., et al. (2023). Recent Advances in the Development of Pyrazole Derivatives as Anticancer Agents. MDPI. Available at: [\[Link\]](#)

- Galal, S. A., et al. (2021). Evaluation of Substituted Pyrazole-Based Kinase Inhibitors in One Decade (2011–2020): Current Status and Future Prospects. *Molecules*. Available at: [\[Link\]](#)
- El-kalyoubi, S. A., et al. (2024). Discovery of Pyrano[2,3-c]pyrazole Derivatives as Novel Potential Human Coronavirus Inhibitors: Design, Synthesis, In Silico, In Vitro, and ADME Studies. *MDPI*. Available at: [\[Link\]](#)
- Al-Issa, S. A. (2013). Biological Validation of Novel Polysubstituted Pyrazole Candidates with in Vitro Anticancer Activities. *MDPI*. Available at: [\[Link\]](#)
- Chalkha, M., et al. (2023). Design, synthesis, characterization, in vitro screening, molecular docking, 3D-QSAR, and ADME-Tox investigations of novel pyrazole derivatives as antimicrobial agents. *ResearchGate*. Available at: [\[Link\]](#)
- Al-Ghorbani, M., et al. (2022). Design, synthesis, molecular modelling and biological evaluation of novel 3-(2-naphthyl)-1-phenyl-1H-pyrazole derivatives as potent antioxidants and 15-Lipoxygenase inhibitors. *PubMed Central*. Available at: [\[Link\]](#)
- ResearchGate. (2025). Virtual screening, Molecular Docking, Molecular Dynamic and ADME of new pyrazole derivatives as anticancer. *ResearchGate*. Available at: [\[Link\]](#)
- Stoddart, L. A., et al. (2015). Evaluating functional ligand-GPCR interactions in cell-based assays. *PubMed Central*. Available at: [\[Link\]](#)
- Eurofins Discovery. (n.d.). GPCR Functional Assays, Understanding On/Off-target Activity. *Eurofins Discovery*. Available at: [\[Link\]](#)

Need Custom Synthesis?

BenchChem offers custom synthesis for rare earth carbides and specific isotopic labeling.

Email: info@benchchem.com or [Request Quote Online](#).

Sources

- [1. pdf.benchchem.com \[pdf.benchchem.com\]](https://pdf.benchchem.com)
- [2. Pyrazole: an emerging privileged scaffold in drug discovery - PMC \[pmc.ncbi.nlm.nih.gov\]](https://pubmed.ncbi.nlm.nih.gov/)

- [3. tandfonline.com](https://www.tandfonline.com) [[tandfonline.com](https://www.tandfonline.com)]
- [4. mdpi.com](https://www.mdpi.com) [[mdpi.com](https://www.mdpi.com)]
- [5. Evaluation of Substituted Pyrazole-Based Kinase Inhibitors in One Decade \(2011–2020\): Current Status and Future Prospects - PMC](#) [[pmc.ncbi.nlm.nih.gov](https://pubmed.ncbi.nlm.nih.gov)]
- [6. Design, Synthesis, and Antitumor Evaluation of 4-Amino-\(1H\)-pyrazole Derivatives as JAKs Inhibitors - PMC](#) [[pmc.ncbi.nlm.nih.gov](https://pubmed.ncbi.nlm.nih.gov)]
- [7. Pharmacophore-Based Virtual Screening and Experimental Validation of Pyrazolone-Derived Inhibitors toward Janus Kinases - PMC](#) [[pmc.ncbi.nlm.nih.gov](https://pubmed.ncbi.nlm.nih.gov)]
- [8. pubs.acs.org](https://pubs.acs.org) [pubs.acs.org]
- [9. pdf.benchchem.com](https://pdf.benchchem.com) [pdf.benchchem.com]
- [10. Discovery of pyrazole-based analogs as CDK2 inhibitors with apoptotic-inducing activity: design, synthesis and molecular dynamics study - RSC Advances \(RSC Publishing\)](#) [pubs.rsc.org]
- [11. Discovery of pyrazole-based analogs as CDK2 inhibitors with apoptotic-inducing activity: design, synthesis and molecular dynamics study - PMC](#) [[pmc.ncbi.nlm.nih.gov](https://pubmed.ncbi.nlm.nih.gov)]
- [12. mdpi.com](https://www.mdpi.com) [[mdpi.com](https://www.mdpi.com)]
- [13. pubs.acs.org](https://pubs.acs.org) [pubs.acs.org]
- [14. pdf.benchchem.com](https://pdf.benchchem.com) [pdf.benchchem.com]
- [15. pubs.acs.org](https://pubs.acs.org) [pubs.acs.org]
- [16. Design, Synthesis, Anticancer Evaluation, Enzymatic Assays, and a Molecular Modeling Study of Novel Pyrazole–Indole Hybrids - PMC](#) [[pmc.ncbi.nlm.nih.gov](https://pubmed.ncbi.nlm.nih.gov)]
- [17. Design, synthesis and in vitro cytotoxicity evaluation of indolo–pyrazoles grafted with thiazolidinone as tubulin polymerization inhibitors - PMC](#) [[pmc.ncbi.nlm.nih.gov](https://pubmed.ncbi.nlm.nih.gov)]
- [18. ClinPGx](https://www.clinpgx.org) [[clinpgx.org](https://www.clinpgx.org)]
- [19. In Vitro and In Vivo Assessment of ADME and PK Properties During Lead Selection and Lead Optimization – Guidelines, Benchmarks and Rules of Thumb - Assay Guidance Manual - NCBI Bookshelf](#) [[ncbi.nlm.nih.gov](https://pubmed.ncbi.nlm.nih.gov)]
- To cite this document: BenchChem. [Application Notes & Protocols for In Vitro Evaluation of Pyrazole-Based Compounds]. BenchChem, [2026]. [Online PDF]. Available at: [<https://www.benchchem.com/product/b1235561/docs#application-notes-protocols-for-in-vitro-evaluation-of-pyrazole-based-compounds>]

Disclaimer & Data Validity:

The information provided in this document is for Research Use Only (RUO) and is strictly not intended for diagnostic or therapeutic procedures. While BenchChem strives to provide accurate protocols, we make no warranties, express or implied, regarding the fitness of this product for every specific experimental setup.

Technical Support: The protocols provided are for reference purposes. Unsure if this reagent suits your experiment?

Need Industrial/Bulk Grade? [Request Custom Synthesis Quote](#)

BenchChem

Our mission is to be the trusted global source of essential and advanced chemicals, empowering scientists and researchers to drive progress in science and industry.

Contact

Address: 3281 E Guasti Rd
Ontario, CA 91761, United States
Phone: (601) 213-4426
Email: info@benchchem.com

[Contact our Ph.D. Support Team for a compatibility check](#)