

An In-depth Technical Guide to the Electron Capture Decay of Thallium-200

Author: BenchChem Technical Support Team. **Date:** April 2026

Compound of Interest

Compound Name: *Thallium-200*

CAS No.: *15720-55-5*

Cat. No.: *B1235120*

[Get Quote](#)

For Researchers, Scientists, and Drug Development Professionals

This technical guide provides a comprehensive overview of the nuclear decay properties of **Thallium-200** (^{200}Tl), focusing on its electron capture decay process. This document details the isotope's production, experimental protocols for its separation and measurement, and its decay characteristics, serving as a vital resource for researchers in nuclear medicine, radiochemistry, and drug development.

Core Decay Properties of Thallium-200

Thallium-200 is a radioactive isotope that decays with a half-life of 26.1 hours.^[1] It undergoes decay exclusively through electron capture (EC) and positron emission (β^+), transforming into the stable isotope Mercury-200 (^{200}Hg).^[1] The total decay energy (QEC) for this process is 2456 keV. The majority of the decay, approximately 98.5%, occurs via electron capture, with a smaller fraction, about 1.5%, proceeding through positron emission.

The decay does not proceed directly to the ground state of ^{200}Hg but rather populates several of its excited nuclear states. The subsequent de-excitation of these states results in the

emission of a spectrum of gamma rays with distinct energies and intensities.

Summary of Decay Data

The key quantitative data for the decay of **Thallium-200** are summarized in the table below for easy reference and comparison.

Property	Value
Half-life (T1/2)	26.1 (1) hours[1]
Decay Mode	Electron Capture (EC), Positron Emission (β^+)
Q-value (QEC)	2456 (6) keV[1]
Daughter Nuclide	200Hg (Stable)
Parent Nuclide	200Pb[1]
Spin and Parity	2-[1]
Branching Ratio (EC)	~98.5%
Branching Ratio (β^+)	~1.5%

Gamma Ray Emissions

The electron capture and positron emission of 200Tl populate various excited states of 200Hg. The subsequent de-excitation of these levels produces a characteristic gamma-ray spectrum. The most prominent gamma emissions are detailed in the following table.

Energy (keV)	Intensity (%)
367.9	88.0
579.3	13.0
828.4	5.0
1205.8	30.0
1477.5	3.0
1594.0	2.0

Experimental Protocols

The production and analysis of **Thallium-200** require specialized facilities and methodologies, from isotope generation in a particle accelerator to radiochemical separation and final measurement.

Production of Thallium-200

Thallium-200 can be produced through several nuclear reactions using a cyclotron. A common method involves the alpha particle bombardment of a gold target.

Reaction: $^{197}\text{Au}(\alpha, n)^{200}\text{Tl}$

Methodology:

- **Target Preparation:** A high-purity (99.99%+) gold foil of a specific thickness (e.g., 60-70 mg/cm²) is used as the target material.
- **Irradiation:** The gold target is irradiated with an alpha particle beam within a specific energy range, typically 22 to 28 MeV. The beam current and irradiation time are optimized to maximize the yield of ²⁰⁰Tl while minimizing the production of isotopic impurities like ¹⁹⁹Tl and ²⁰¹Tl.
- **Target Cooling:** Following irradiation, the target is allowed to cool for a sufficient period to permit the decay of short-lived, undesired radioisotopes.

An alternative production route is the irradiation of a massive mercury target with high-energy protons (e.g., 660 MeV).[2]

Radiochemical Separation of Thallium-200 from Gold Target

After irradiation, the ^{200}Tl must be chemically separated from the bulk gold target and any other contaminants. A robust method for this separation is ion exchange chromatography.

Methodology:

- **Target Dissolution:** The irradiated gold foil is dissolved in a minimal volume of aqua regia (a mixture of nitric acid and hydrochloric acid, typically in a 1:3 molar ratio). The solution is then gently heated to ensure complete dissolution.
- **Column Preparation:** An anion exchange resin (e.g., Dowex 1x8) is prepared in a chromatography column and pre-conditioned with concentrated hydrochloric acid (HCl).
- **Separation:**
 - The dissolved target solution is evaporated to near dryness and re-dissolved in concentrated HCl.
 - In the high chloride concentration of the HCl, gold forms a stable anionic complex ($[\text{AuCl}_4]^-$), which is strongly retained by the anion exchange resin.
 - Thallium, existing as a cation (Tl^+ or Tl^{3+}), does not form a strong anionic complex under these conditions and will pass through the column.
 - The column is washed with additional concentrated HCl to ensure the complete elution of thallium.
- **Product Purification:** The eluted thallium fraction can be further purified by evaporating the HCl and re-dissolving the residue in a suitable solvent or buffer for subsequent use.

Measurement and Quantification

The activity and purity of the separated ^{200}Tl are determined using gamma-ray spectrometry.

Methodology:

- **Sample Preparation:** An aliquot of the purified ^{200}Tl solution is placed in a standard geometry vial for counting.
- **Instrumentation:** A high-purity germanium (HPGe) detector, which offers excellent energy resolution, is used for the measurement. The detector is coupled to a multichannel analyzer (MCA) to acquire the energy spectrum.
- **Data Acquisition:** The sample is counted for a sufficient time to obtain statistically significant data in the photopeaks of interest (e.g., 367.9 keV, 1205.8 keV).
- **Analysis:** The resulting gamma-ray spectrum is analyzed to identify the characteristic photopeaks of ^{200}Tl . The area under these peaks is proportional to the activity of the radionuclide, which can be quantified by comparing it to the detector's efficiency calibration at those energies. The spectrum is also scrutinized for the presence of peaks from any radionuclidic impurities.

Visualized Processes and Workflows

To further clarify the concepts discussed, the following diagrams illustrate the decay scheme of **Thallium-200** and a typical experimental workflow for its production and analysis.

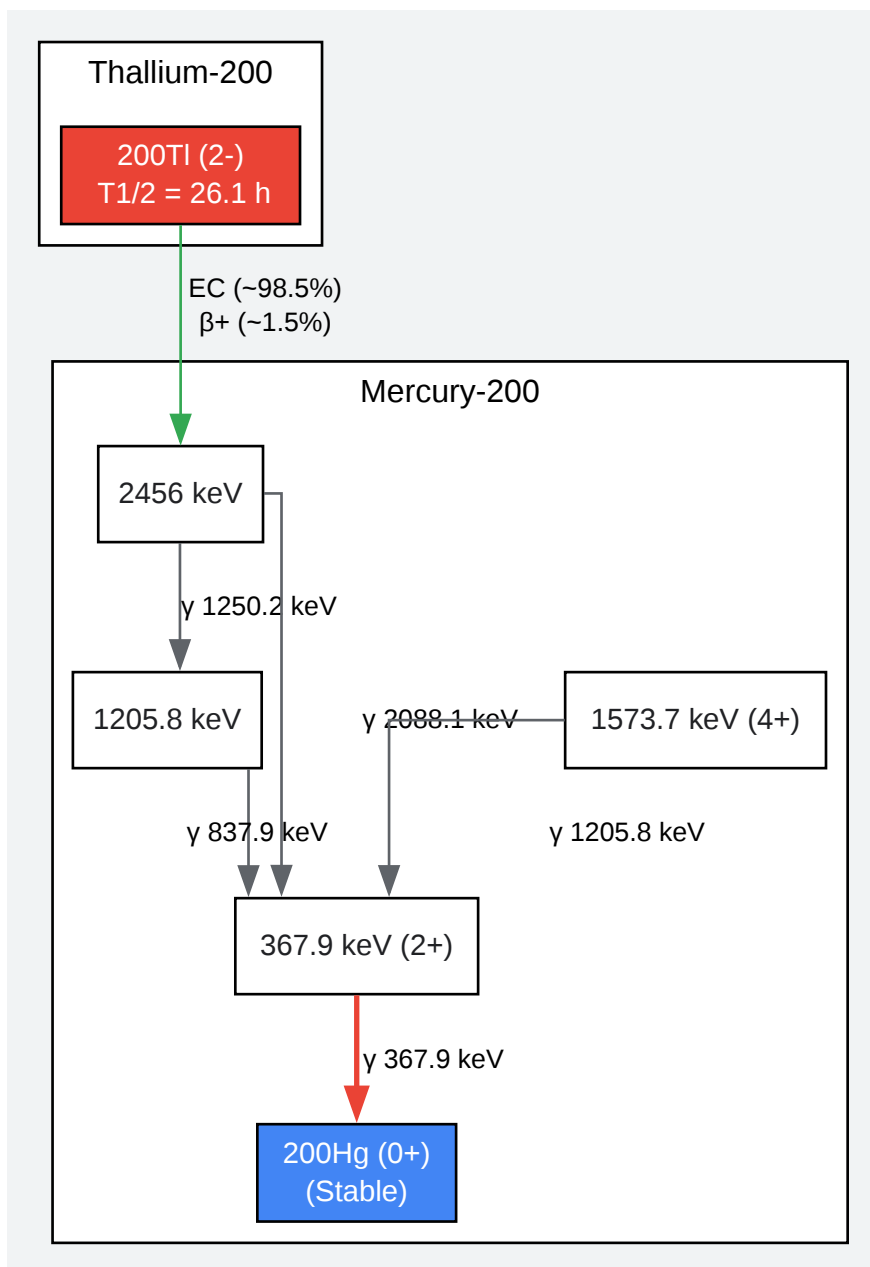

[Click to download full resolution via product page](#)

Caption: Simplified decay scheme of **Thallium-200**.

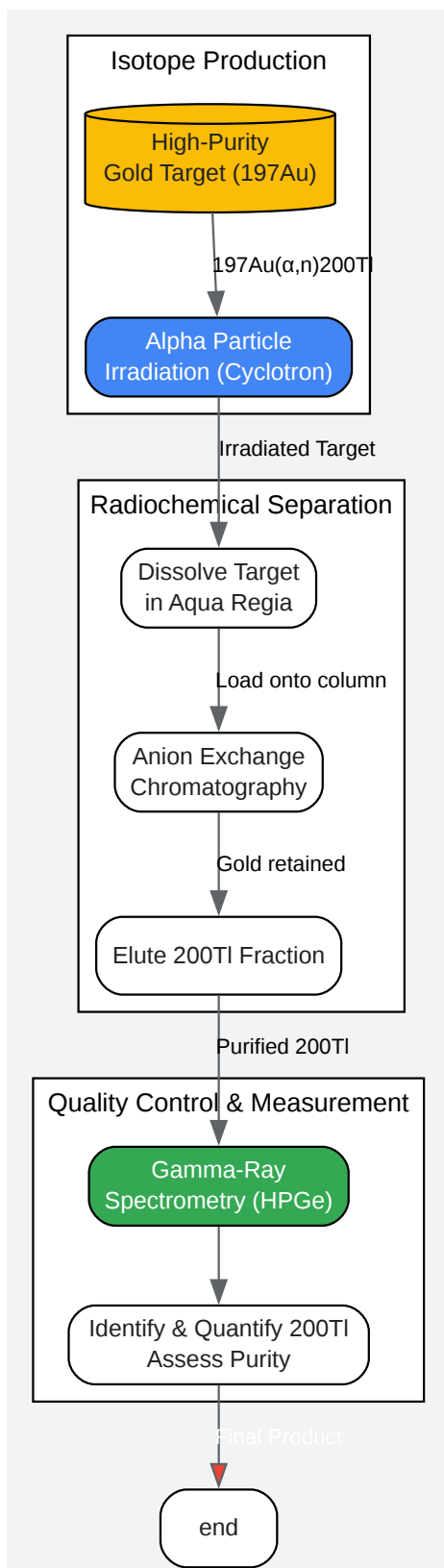

[Click to download full resolution via product page](#)

Caption: Experimental workflow for **Thallium-200** production.

Relevance for Researchers and Drug Development

While Thallium-201 is well-established in nuclear cardiology, the properties of ^{200}Tl are less explored for direct clinical applications, partly due to its higher energy gamma emissions.

However, understanding its production and decay is crucial for several reasons:

- **Isotopic Purity:** In the production of other thallium radioisotopes for medical use, ^{200}Tl can be an isotopic impurity. Accurate knowledge of its decay characteristics is essential for quantifying and correcting for its presence to ensure the quality and safety of radiopharmaceuticals.
- **Research Applications:** As a tracer in preclinical research, ^{200}Tl can be used in studies requiring a nuclide with a half-life of approximately one day. Its decay properties allow for clear detection and quantification.
- **Toxicity Studies:** All thallium isotopes are chemically identical and highly toxic. Research into the cellular mechanisms of thallium toxicity, including its ability to mimic potassium ions and disrupt cellular processes, is relevant to toxicology and drug development. Recent studies have even investigated the antiproliferative effects of thallium ions on cancer cells, suggesting potential, albeit challenging, therapeutic avenues.

Need Custom Synthesis?

BenchChem offers custom synthesis for rare earth carbides and specific isotopic labeling.

Email: info@benchchem.com or [Request Quote Online](#).

References

- [1. Thallium-200 - isotopic data and properties \[chemlin.org\]](#)
- [2. Massive mercury target for thallium isotope production using beam of high energy protons \[inis.iaea.org\]](#)
- To cite this document: BenchChem. [An In-depth Technical Guide to the Electron Capture Decay of Thallium-200]. BenchChem, [2026]. [Online PDF]. Available at: [\[https://www.benchchem.com/product/b1235120/docs#an-in-depth-technical-guide-to-the-electron-capture-decay-of-thallium-200\]](https://www.benchchem.com/product/b1235120/docs#an-in-depth-technical-guide-to-the-electron-capture-decay-of-thallium-200)

Disclaimer & Data Validity:

The information provided in this document is for Research Use Only (RUO) and is strictly not intended for diagnostic or therapeutic procedures. While BenchChem strives to provide accurate protocols, we make no warranties, express or implied, regarding the fitness of this product for every specific experimental setup.

Technical Support: The protocols provided are for reference purposes. Unsure if this reagent suits your experiment?

Need Industrial/Bulk Grade? [Request Custom Synthesis Quote](#)

BenchChem

Our mission is to be the trusted global source of essential and advanced chemicals, empowering scientists and researchers to drive progress in science and industry.

Contact

Address: 3281 E Guasti Rd
Ontario, CA 91761, United States
Phone: (601) 213-4426
Email: info@benchchem.com

[Contact our Ph.D. Support Team for a compatibility check](#)