

A Technical Guide to *cis,trans*-Germacrone: Natural Sources, Isolation, and Biological Activity

Author: BenchChem Technical Support Team. **Date:** April 2026

Compound of Interest

Compound Name: *cis,trans*-Germacrone

Cat. No.: B1235385

[Get Quote](#)

For Researchers, Scientists, and Drug Development Professionals

Introduction

Germacrone is a naturally occurring sesquiterpenoid belonging to the germacrane class, which is characterized by a 10-membered carbon ring. It exists as several stereoisomers, with the (E,E)-isomer, commonly referred to as *trans,trans*-germacrone, being the most abundant in nature. This technical guide focuses on ***cis,trans*-germacrone**, an isomer that, while not the predominant natural form, is of significant interest due to its potential biological activities. This document provides a comprehensive overview of the natural sources of germacrone, with a focus on the prevalence of the *trans,trans* isomer, methods for its isolation and quantification, and the photochemical conversion to the *cis,trans* isomer. Furthermore, it delves into the known biological activities and associated signaling pathways of germacrone, with the caveat that most existing research has been conducted on the readily available *trans,trans* isomer.

Natural Sources and Abundance of Germacrone

Germacrone is a major constituent of the essential oils of various plants, particularly within the Zingiberaceae (ginger) and Rhododendron families. While the literature predominantly refers to the compound as "germacrone," it is widely accepted that this denotes the more stable (E,E)- or trans,trans-isomer. The natural occurrence of the cis,trans-isomer is not well-documented and, if present, is likely in trace amounts. The primary route to obtaining **cis,trans-germacrone** is through the photochemical isomerization of the trans,trans isomer.

Quantitative Data of Germacrone in Natural Sources

The following table summarizes the quantitative data for germacrone (presumed to be the trans,trans-isomer) found in the essential oils of various plant species.

Plant Species	Family	Plant Part	Germacrone Content (%)	Reference
Curcuma aeruginosa	Zingiberaceae	Rhizome	5.3	[1]
Curcuma zedoaria	Zingiberaceae	Rhizome	2.3	[1]
Curcuma wenyujin	Zingiberaceae	Rhizome	Not specified, but a major component	[2]
Curcuma longa (Turmeric)	Zingiberaceae	Rhizome	11	
Rhododendron thymifolium	Ericaceae	Not specified	20.83	

Experimental Protocols

Extraction and Isolation of (E,E)-Germacrone from Plant Material

A common method for the extraction and isolation of (E,E)-germacrone from plant rhizomes, such as those from Curcuma species, is steam distillation followed by chromatographic purification.

a) Steam Distillation:

- Fresh or dried rhizomes are ground into a coarse powder.
- The powdered material is subjected to steam distillation for several hours.
- The collected distillate, containing the essential oil and water, is placed in a separatory funnel.
- The essential oil layer is separated from the aqueous layer.
- The oil is dried over anhydrous sodium sulfate to remove residual water.

b) High-Speed Counter-Current Chromatography (HSCCC) for Purification:

High-speed counter-current chromatography is an effective technique for the preparative isolation and purification of germacrone from the crude essential oil[3].

- Solvent System Selection: A suitable two-phase solvent system is selected. For example, a petroleum ether-ethanol-diethyl ether-water (5:4:0.5:1, v/v/v/v) system has been used successfully[3].
- HSCCC Operation:
 - The coiled column of the HSCCC instrument is first filled with the lower phase (stationary phase).
 - The upper phase (mobile phase) is then pumped through the column at a specific flow rate while the apparatus is rotated at a set speed.
 - The essential oil sample, dissolved in a mixture of the upper and lower phases, is injected into the column.
- Fraction Collection and Analysis: Fractions are collected and analyzed by High-Performance Liquid Chromatography (HPLC) or Gas Chromatography-Mass Spectrometry (GC-MS) to identify and pool the fractions containing pure germacrone.

Quantification of Germacrone by Gas Chromatography-Mass Spectrometry (GC-MS)

GC-MS is a standard method for the quantitative analysis of volatile compounds like germacrone in essential oils.

- Sample Preparation: The essential oil is diluted in a suitable solvent (e.g., hexane or ethanol).
- GC-MS Analysis:
 - An appropriate GC column (e.g., a non-polar capillary column like DB-5ms) is used.
 - The oven temperature is programmed to separate the components of the essential oil. A typical program might start at a lower temperature and ramp up to a higher temperature.
 - Helium is commonly used as the carrier gas.
 - The mass spectrometer is operated in electron ionization (EI) mode.
- Quantification: The percentage of germacrone is determined by comparing the peak area of germacrone to the total peak area of all identified compounds (area normalization method). For more accurate quantification, a calibration curve can be prepared using a pure standard of germacrone.

Photochemical Isomerization of (E,E)-Germacrone to cis,trans-Germacrone

The cis,trans-isomer of germacrone can be obtained from the naturally abundant trans,trans-isomer through photochemical isomerization[1].

- Reaction Setup: A solution of (E,E)-germacrone in a suitable solvent (e.g., ether) is prepared in a quartz reaction vessel. A photosensitizer, such as acetophenone, is often added.
- Irradiation: The solution is irradiated with a high-pressure mercury lamp or another suitable UV light source. The reaction is typically carried out under an inert atmosphere (e.g., nitrogen or argon) to prevent photo-oxidation.

- **Monitoring and Work-up:** The progress of the isomerization is monitored by techniques like TLC or GC. Upon completion, the solvent is evaporated.
- **Separation of Isomers:** The resulting mixture of isomers (cis,trans-, cis,cis-, and remaining trans,trans-germacrone) can be separated by column chromatography on silica gel, taking advantage of the different polarities of the isomers.

Biological Activities and Signaling Pathways of Germacrone

Disclaimer: The vast majority of studies on the biological activity of germacrone have been conducted using "germacrone" isolated from natural sources, which is predominantly the (E,E)- or trans,trans-isomer. Specific studies on the biological effects of pure **cis,trans-germacrone** are scarce. Therefore, the following information should be interpreted with the understanding that it likely pertains to the trans,trans-isomer.

Germacrone has been reported to exhibit a wide range of pharmacological activities, including anti-inflammatory, anticancer, and antiviral effects.

Anticancer Activity

Germacrone has been shown to inhibit the proliferation of various cancer cell lines, including breast cancer, liver cancer, and glioblastoma. The proposed mechanisms of action involve the induction of cell cycle arrest and apoptosis. Several signaling pathways have been implicated in the anticancer effects of germacrone.

- **JAK2/STAT3 Pathway:** In human hepatoma HepG2 cells, germacrone has been found to induce apoptosis through the inhibition of the Janus kinase 2/signal transducer and activator of transcription 3 (JAK2/STAT3) signaling pathway.
- **PI3K/AKT/mTOR Pathway:** Germacrone has also been shown to modulate the phosphatidylinositol 3-kinase (PI3K)/protein kinase B (AKT)/mammalian target of rapamycin (mTOR) pathway, which is a critical regulator of cell proliferation, survival, and growth.
- **c-Met Signaling Pathway:** Studies on germacrone derivatives have suggested that they can inhibit the c-Met kinase, a receptor tyrosine kinase that plays a role in cell motility, invasion, and proliferation[4].

Below is a diagram illustrating the potential involvement of germacrone in inhibiting cancer cell proliferation through these pathways.

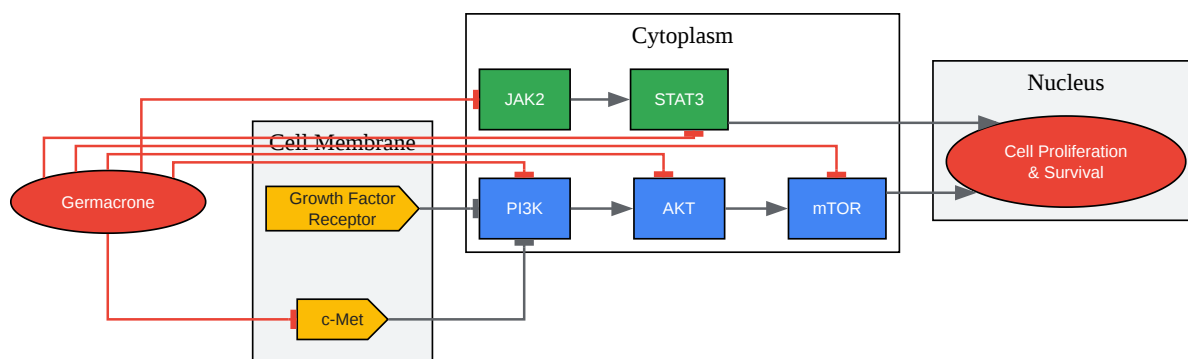

[Click to download full resolution via product page](#)

Caption: Putative signaling pathways inhibited by germacrone in cancer cells.

Antiviral Activity

Germacrone has demonstrated inhibitory effects against the influenza virus. It is suggested that germacrone interferes with the early stages of viral replication.

The workflow for investigating the antiviral activity of germacrone can be visualized as follows:



[Click to download full resolution via product page](#)

Caption: Experimental workflow for assessing the antiviral activity of germacrone.

Conclusion

cis,trans-Germacrone represents an intriguing, albeit less abundant, isomer of the naturally occurring sesquiterpenoid germacrone. While its direct natural sources are not well-established, it can be readily synthesized from the prevalent trans,trans-isomer via photochemical methods. The biological activities of germacrone are extensive, with significant potential in anticancer and antiviral applications, primarily attributed to the trans,trans-isomer. Further research is warranted to specifically elucidate the pharmacological profile of **cis,trans-germacrone** and to compare its efficacy and mechanisms of action with its more abundant stereoisomer. Such studies will be crucial for unlocking the full therapeutic potential of this class of compounds in drug development.

Need Custom Synthesis?

BenchChem offers custom synthesis for rare earth carbides and specific isotopic labeling.

Email: info@benchchem.com or [Request Quote Online](#).

References

- 1. Preparation of some cis-1,trans-5-germacatriene derivatives - Journal of the Chemical Society D: Chemical Communications (RSC Publishing) [pubs.rsc.org]
- 2. Chemical composition and antimicrobial activity of three essential oils from Curcuma wenyujin - PubMed [pubmed.ncbi.nlm.nih.gov]
- 3. [benchchem.com](https://www.benchchem.com) [[benchchem.com](https://www.benchchem.com)]
- 4. Germacrone derivatives: synthesis, biological activity, molecular docking studies and molecular dynamics simulations - PMC [[pmc.ncbi.nlm.nih.gov](https://pubmed.ncbi.nlm.nih.gov)]
- To cite this document: BenchChem. [A Technical Guide to cis,trans-Germacrone: Natural Sources, Isolation, and Biological Activity]. BenchChem, [2026]. [Online PDF]. Available at: [<https://www.benchchem.com/product/b1235385/docs#a-technical-guide-to-cis-trans-germacrone-natural-sources-isolation-and-biological-activity>]

Disclaimer & Data Validity:

The information provided in this document is for Research Use Only (RUO) and is strictly not intended for diagnostic or therapeutic procedures. While BenchChem strives to provide accurate protocols, we make no warranties, express or implied, regarding the fitness of this product for every specific experimental setup.

Technical Support: The protocols provided are for reference purposes. Unsure if this reagent suits your experiment?

Need Industrial/Bulk Grade? [Request Custom Synthesis Quote](#)

BenchChem

Our mission is to be the trusted global source of essential and advanced chemicals, empowering scientists and researchers to drive progress in science and industry.

Contact

Address: 3281 E Guasti Rd
Ontario, CA 91761, United States
Phone: (601) 213-4426
Email: info@benchchem.com

[Contact our Ph.D. Support Team for a compatibility check](#)