

# Sulfonyl-Piperazine Building Blocks: A Technical Guide for Medicinal Chemistry

**Author:** BenchChem Technical Support Team. **Date:** April 2026

## Compound of Interest

Compound Name: *1-(Ethanesulfonyl)-2-methylpiperazine*

Cat. No.: *B12340446*

[Get Quote](#)

## Executive Summary

This technical guide analyzes the sulfonyl-piperazine moiety (

), a privileged scaffold in modern drug discovery.[1] Unlike simple piperazines, the sulfonyl-piperazine motif offers unique physicochemical properties, including enhanced metabolic stability, distinct hydrogen-bonding vectors, and rigid geometrical constraints.[1] This guide details the synthetic accessibility, reactivity profiles, and structure-activity relationship (SAR) logic required to deploy these building blocks effectively in hit-to-lead optimization.

## Introduction: The Sulfonyl-Piperazine Scaffold

The piperazine ring is ubiquitous in FDA-approved drugs (e.g., Imatinib, Ciprofloxacin, Aripiprazole), typically serving as a solubility-enhancing linker.[1] However, the sulfonyl-piperazine subclass represents a distinct pharmacological space.

The sulfonyl group (

) acts as a bioisostere for carbonyls but introduces a tetrahedral geometry that alters the spatial orientation of the piperazine substituents. This scaffold is critical in:

- GPCR Modulators: Targeting 5-HT and Dopamine receptors.
- Enzyme Inhibitors: Specifically LpxH (antibacterial) and Steroid Sulfatase (oncology).[1]
- Ion Channel Blockers: Modulation of voltage-gated channels.

## Structural Advantages[1][2][3][4][5]

- Metabolic Stability: The sulfonamide bond is significantly more resistant to amidases and proteases than the corresponding carboxamide.
- Dipole Orientation: The strong electron-withdrawing nature of the sulfonyl group reduces the basicity of the attached nitrogen ( ), while leaving the distal nitrogen ( ) basic (pKa ~8.5–9.0), allowing for tunable ionization at physiological pH.[1]

## Synthetic Methodologies

The synthesis of sulfonyl-piperazine building blocks generally follows two strategic pathways: Direct Sulfonylation (Route A) and Convergent Assembly (Route B).

### Route A: Direct Sulfonylation (The Standard Protocol)

This is the most common route for generating mono-sulfonyl piperazine building blocks. The challenge lies in desymmetrization—preventing the formation of the bis-sulfonyl byproduct.

Mechanism: Nucleophilic attack of the piperazine nitrogen on the electrophilic sulfur of the sulfonyl chloride. Selectivity Control:

- Stoichiometry: Use of excess piperazine (3–5 equivalents) is the most effective method to ensure mono-substitution.
- pH Control: Maintaining a pH < 9 can protonate one nitrogen of the piperazine (pKa ~9.8), rendering it non-nucleophilic, while the free base reacts.[1]
- Protecting Groups: Using N-Boc-piperazine guarantees mono-functionalization, followed by TFA deprotection.[1]

## Route B: Solid-Phase Synthesis

For high-throughput library generation, resin-bound piperazines are reacted with diverse sulfonyl chlorides.[1] This method is preferred for SAR exploration.

## Visualization: Synthetic Workflow

The following diagram illustrates the divergent synthesis of sulfonyl-piperazine libraries.

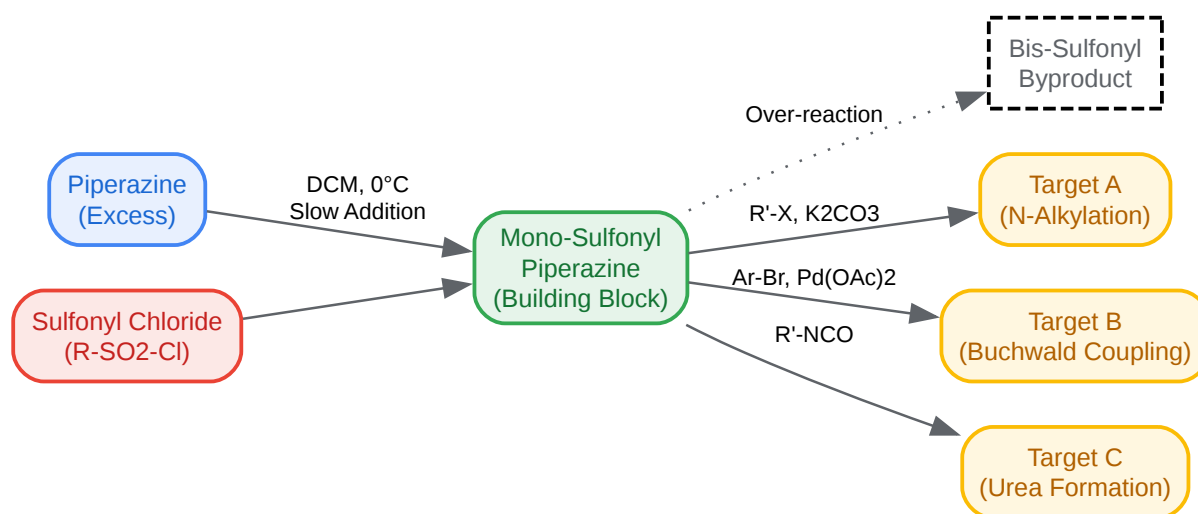

[Click to download full resolution via product page](#)

Caption: Divergent synthesis starting from piperazine desymmetrization to diverse medicinal targets.

## Reactivity Profile & Stability

Understanding the chemical behavior of the sulfonyl-piperazine core is essential for process chemistry.

Parameter	Characteristic	Implication for Drug Design
Sulfonamide Bond Stability	High	Resistant to hydrolysis under acidic/basic conditions; stable in plasma.
Basicity	Moderate (pKa ~8.5)	Allows for salt formation (HCl, Mesylate) to improve solubility. [1]
Nucleophilicity	Negligible	The sulfonyl-attached nitrogen is non-nucleophilic due to electron withdrawal.
Metabolic Liability	Low	Sulfonamides are generally "metabolic dead ends," unlike amides which can be cleaved. [1]

Key Reactivity Note: The sulfonyl group deactivates the piperazine ring toward oxidation, making these building blocks compatible with oxidative reaction steps (e.g., KMnO<sub>4</sub> oxidations elsewhere in the molecule) that might otherwise degrade an alkyl-piperazine.[1]

## Medicinal Chemistry Applications (SAR)[1]

### Antibacterial Agents (LpxH Inhibitors)

Recent work on LpxH inhibitors (essential for lipid A biosynthesis in Gram-negative bacteria) has highlighted the sulfonyl-piperazine scaffold.[2]

- Mechanism: The sulfonyl group positions the piperazine ring to interact with the active site of LpxH, while the distal nitrogen accepts substituents that penetrate the hydrophobic tunnel.
- SAR Insight: A "linker" function. The sulfonyl group provides a rigid distance constraint that is distinct from a carbonyl linker.

### CNS Agents (GlyT-1 Inhibitors)

In Glycine Transporter-1 (GlyT-1) inhibitors, the sulfonyl-piperazine moiety is used to modulate lipophilicity (LogP) and penetrate the Blood-Brain Barrier (BBB).[1]

- Optimization: Replacing a carboxamide with a sulfonamide often lowers the Polar Surface Area (PSA) slightly while maintaining hydrogen bond acceptor capability, potentially improving BBB permeability.[1]

## Visualization: Pharmacophore Mapping

This diagram represents the SAR logic derived from LpxH and GlyT-1 inhibitor studies.

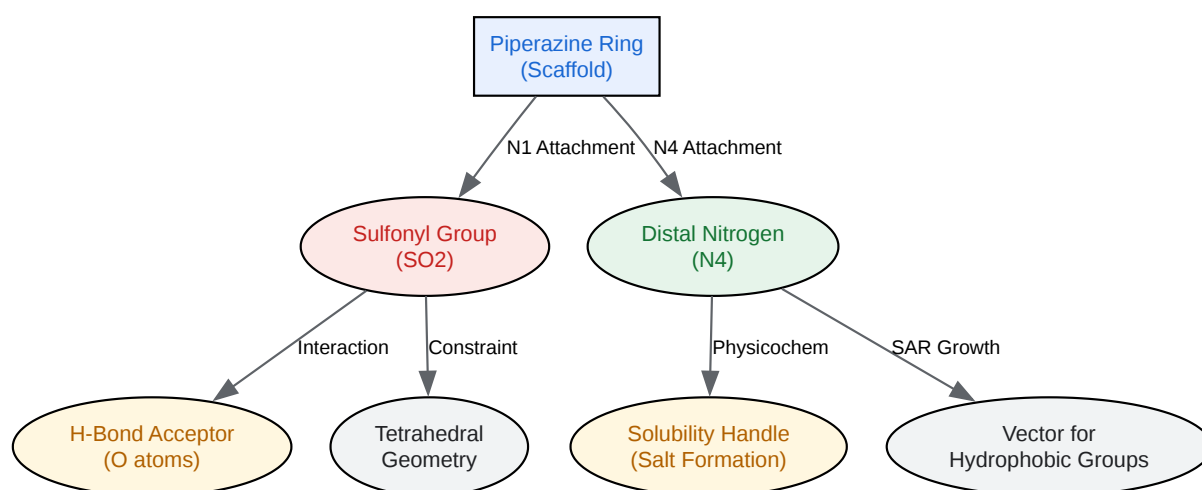

[Click to download full resolution via product page](#)

Caption: Pharmacophore dissection of the sulfonyl-piperazine scaffold illustrating key binding interactions.

## Experimental Protocols

### Protocol 1: General Synthesis of 1-(Arylsulfonyl)piperazine

This protocol utilizes N-Boc protection to ensure high purity and yield.

Reagents:

- N-Boc-piperazine (1.0 equiv)[1]
- Arylsulfonyl chloride (1.1 equiv)[1]
- Triethylamine ( , 1.5 equiv)[1]
- Dichloromethane (DCM)[1]
- Trifluoroacetic acid (TFA)[1][3]

#### Step-by-Step Methodology:

- **Sulfonylation:** Dissolve N-Boc-piperazine (10 mmol) in anhydrous DCM (50 mL). Add (15 mmol) and cool to 0°C.
- **Addition:** Dropwise add a solution of Arylsulfonyl chloride (11 mmol) in DCM (10 mL) over 30 minutes.
- **Reaction:** Warm to room temperature and stir for 4 hours (Monitor by TLC/LCMS).
- **Workup:** Wash with water (2x), saturated , and brine. Dry over and concentrate to yield the N-Boc-N'-sulfonyl intermediate.
- **Deprotection:** Dissolve the intermediate in DCM (20 mL) and add TFA (5 mL). Stir at room temperature for 2 hours.
- **Isolation:** Concentrate in vacuo. Basify with 1N NaOH to pH 10 and extract with DCM. The organic layer yields the free amine 1-(Arylsulfonyl)piperazine.

#### Validation Criteria:

- **<sup>1</sup>H NMR:** Look for the disappearance of the Boc singlet (~1.4 ppm) and the retention of the piperazine methylene protons (~2.8-3.0 ppm).

- LCMS: [M+H]<sup>+</sup> peak corresponding to the mono-sulfonylated product.

## Protocol 2: N-Alkylation of Sulfonyl-Piperazines

Used to attach the "Right-Hand Side" (RHS) of the molecule.

- Dissolve 1-(Arylsulfonyl)piperazine (1.0 equiv) in Acetonitrile (ACN).<sup>[1]</sup>
- Add  
  
(2.0 equiv) and the alkyl halide (1.1 equiv).
- Heat to reflux (60-80°C) for 6–12 hours.
- Filter off inorganic salts and concentrate. Purify via silica gel chromatography.

## Case Studies

### Case Study A: LpxH Inhibitors (Antibacterial)

Challenge: Developing antibiotics against Gram-negative bacteria with novel mechanisms.

Solution: Researchers utilized a sulfonyl-piperazine linker to connect a hydrophobic trifluoromethyl-phenyl group with an N-acetyl indoline moiety. Outcome: The sulfonyl group provided the necessary rigidity to traverse the LpxH active site tunnel, a property that flexible alkyl linkers failed to provide. The resulting compound (AZ1 analogs) showed potent MICs against E. coli.

### Case Study B: GlyT-1 Inhibitors (Schizophrenia)

Challenge: Improving the metabolic stability of GlyT-1 inhibitors. Solution: Replacement of a labile amide bond with a sulfonamide within a piperazine scaffold. Outcome: The sulfonyl-piperazine analog retained potency (

< 50 nM) but exhibited a 3-fold increase in half-life (

) in microsomal stability assays, validating the scaffold as a "metabolic shield."<sup>[1]</sup>

## References

- Piperazine Derivatives: A Privileged Scaffold in Modern Synthesis and Medicinal Chemistry. *Journal of Molecular Structure*. (2026). [[Link](#)]
- Structure–Activity Relationship of Sulfonyl Piperazine LpxH Inhibitors Analyzed by an LpxE-Coupled Malachite Green Assay. *ACS Infectious Diseases*. (2019). [[Link](#)][1]
- Synthesis and Biological Evaluation of N-((1-(4-(Sulfonyl)piperazin-1-yl)cycloalkyl)methyl)benzamide Inhibitors of Glycine Transporter-1. *Journal of Medicinal Chemistry*. (2016). [1][4] [[Link](#)][1][4]
- Synthetic Approaches to Piperazine-Containing Drugs Approved by FDA in the Period of 2011–2023. *Molecules*. (2023). [[Link](#)][1]
- Lasamide Containing Sulfonylpiperazines as Effective Agents for the Management of Glaucoma Associated Symptoms. *ChemistryMedChem*. (2024). [[Link](#)][1]

#### Need Custom Synthesis?

BenchChem offers custom synthesis for rare earth carbides and specific isotopic labeling.

Email: [info@benchchem.com](mailto:info@benchchem.com) or [Request Quote Online](#).

## Sources

- 1. Novel sulfamethoxazole and 1-(2-fluorophenyl) piperazine derivatives as potential apoptotic and antiproliferative agents by inhibition of BCL2; design, synthesis, biological evaluation, and docking studies - PMC [[pmc.ncbi.nlm.nih.gov](https://pubmed.ncbi.nlm.nih.gov)]
- 2. Structure–Activity Relationship of Sulfonyl Piperazine LpxH Inhibitors Analyzed by an LpxE-Coupled Malachite Green Assay - PMC [[pmc.ncbi.nlm.nih.gov](https://pubmed.ncbi.nlm.nih.gov)]
- 3. Piperazine Derivatives: A Privileged Scaffold in Modern Synthesis and Medicinal Chemistry - PMC [[pmc.ncbi.nlm.nih.gov](https://pubmed.ncbi.nlm.nih.gov)]
- 4. Synthesis and Biological Evaluation of N-((1-(4-(Sulfonyl)piperazin-1-yl)cycloalkyl)methyl)benzamide Inhibitors of Glycine Transporter-1 - PubMed [[pubmed.ncbi.nlm.nih.gov](https://pubmed.ncbi.nlm.nih.gov)]
- To cite this document: BenchChem. [Sulfonyl-Piperazine Building Blocks: A Technical Guide for Medicinal Chemistry]. BenchChem, [2026]. [Online PDF]. Available at:

[\[https://www.benchchem.com/product/b12340446/docs#sulfonyl-piperazine-building-blocks-a-technical-guide-for-medicinal-chemistry\]](https://www.benchchem.com/product/b12340446/docs#sulfonyl-piperazine-building-blocks-a-technical-guide-for-medicinal-chemistry)

### Disclaimer & Data Validity:

The information provided in this document is for Research Use Only (RUO) and is strictly not intended for diagnostic or therapeutic procedures. While BenchChem strives to provide accurate protocols, we make no warranties, express or implied, regarding the fitness of this product for every specific experimental setup.

**Technical Support:** The protocols provided are for reference purposes. Unsure if this reagent suits your experiment?

**Need Industrial/Bulk Grade?** [Request Custom Synthesis Quote](#)

## BenchChem

Our mission is to be the trusted global source of essential and advanced chemicals, empowering scientists and researchers to drive progress in science and industry.

### Contact

Address: 3281 E Guasti Rd  
Ontario, CA 91761, United States  
Phone: (601) 213-4426  
Email: [info@benchchem.com](mailto:info@benchchem.com)

[Contact our Ph.D. Support Team for a compatibility check](#)