

# Topic: Discovery and Initial Characterization of Dihydroceramides

**Author:** BenchChem Technical Support Team. **Date:** May 2026

## Compound of Interest

Compound Name: *N*-(tetracosanoyl)-sphinganine

CAS No.: 6063-36-1

Cat. No.: B1234198

[Get Quote](#)

## Abstract

For decades, dihydroceramides (dhCers) were relegated to a minor role in cellular biology, viewed merely as inert metabolic intermediates in the conserved de novo sphingolipid synthesis pathway.<sup>[1][2][3][4][5]</sup> This guide provides a comprehensive technical overview of the pivotal discoveries and foundational characterization studies that challenged this dogma. We will deconstruct the paradigm shift that elevated dihydroceramides from biochemical footnotes to a distinct class of bioactive lipids implicated in critical cellular processes such as autophagy, cell cycle regulation, and stress responses.<sup>[1][3][4]</sup> This document is structured to provide not just protocols, but the scientific rationale behind the experimental choices, offering field-proven insights for professionals engaged in lipid research and therapeutic development.

## Part I: The Discovery - From Inert Precursor to Bioactive Lipid

### The Prevailing Dogma: An Inactive Waypoint

The journey of dihydroceramides begins within the endoplasmic reticulum, at the heart of the de novo sphingolipid synthesis pathway.[1][2][6] This pathway commences with the condensation of serine and palmitoyl-CoA and proceeds through several steps to produce sphinganine. The acylation of sphinganine by one of six ceramide synthase (CerS) enzymes yields dihydroceramide.[1] For a significant period, the story of dhCer ended here, positioning it as the immediate and seemingly unremarkable precursor to ceramide (Cer). The final, and what was considered the most critical, step is the introduction of a 4,5-trans-double bond into the sphingoid backbone of dhCer by the enzyme dihydroceramide desaturase (DEGS1), yielding the far more abundant and well-studied ceramide.[1][7][8][9][10][11]

Early research solidified this view. Foundational studies on sphingolipid signaling often employed short-chain, water-soluble lipid analogs to probe cellular functions. Experiments using these tools consistently demonstrated that C2-ceramide could induce apoptosis and arrest cell growth, whereas its saturated counterpart, C2-dihydroceramide, was ineffective.[2] This apparent lack of activity, observed across multiple assays, cemented the dogma that dihydroceramides were biologically inert.

## The Paradigm Shift: A Critical Re-evaluation Fueled by Technology

The re-evaluation of dihydroceramide's role was not driven by a new hypothesis, but by an unexpected experimental result. The synthetic retinoid fenretinide (4-HPR) was a compound of interest in oncology due to its established ability to induce apoptosis in cancer cells.[2] The prevailing mechanism of action was thought to involve the elevation of intracellular ceramide levels.

A critical breakthrough came in 2006 from the Merrill group, who leveraged the precision of modern lipidomics.[2][12] Instead of relying on older methods that could not reliably distinguish between ceramide and dihydroceramide, they applied liquid chromatography-tandem mass spectrometry (LC-MS/MS). The results were startling: treating human prostate cancer cells with fenretinide did not increase ceramide, but instead caused a massive accumulation of various dihydroceramide species.[12] This seminal finding revealed that fenretinide's actual target was the enzyme DEGS1; by inhibiting it, the conversion of dhCer to ceramide was blocked, leading to a buildup of the precursor.[12]

This discovery was the first unequivocal evidence that a cellular phenotype could be correlated with the accumulation of endogenous, long-chain dihydroceramides. It single-handedly reopened the investigation into their potential bioactivity and served as a powerful lesson in the importance of analytical specificity in biological research.

## Part II: Biochemical and Biophysical

### Characterization

#### Dihydroceramide Desaturase (DEGS1): The Gatekeeper Enzyme

The discovery of fenretinide's true mechanism of action placed DEGS1 at the center of dihydroceramide biology. This enzyme is the crucial gatekeeper that controls the balance between dihydroceramides and ceramides.[9]

- **Function:** DEGS1 is an ER-resident enzyme that catalyzes the final step in de novo ceramide synthesis: the desaturation of the sphinganine backbone of dihydroceramide to create ceramide.[6][13]
- **Cofactor Requirements:** The reaction requires molecular oxygen and a reduced pyridine nucleotide (NADH or NADPH) as a co-substrate.[11] This dependency on oxygen is critical, as it positions DEGS1 as a cellular oxygen sensor; under hypoxic conditions, its activity decreases, leading to a natural accumulation of dihydroceramides.[1][6]
- **Experimental Utility:** The ability to modulate DEGS1 activity became the cornerstone of modern dhCer research. Pharmacological inhibitors (e.g., fenretinide, GT11) and genetic tools (e.g., siRNA) that target DEGS1 provided researchers with a reliable method to specifically increase the intracellular dhCer/Cer ratio and study the downstream consequences.[2][7][10][14]

#### The Structural Distinction and Its Biophysical Consequences

The only difference between a dihydroceramide and a ceramide molecule is the absence of the 4,5-trans-double bond.[1][15] This seemingly minor structural variation has profound implications for the biophysical properties of the lipid and the membranes they inhabit.

The double bond in ceramide introduces a kink in the molecule, which affects its packing behavior and the fluidity of the lipid bilayer.[1][6] In contrast, the saturated backbone of dihydroceramide allows for tighter, more ordered packing. This distinction is not merely academic; it directly impacts function. For instance, ceramide is known to self-associate in membranes to form channels, particularly in the outer mitochondrial membrane, which facilitates the release of pro-apoptotic proteins. Dihydroceramide, due to its different geometry and packing properties, is incapable of forming these channels, explaining in part why it is a much weaker inducer of apoptosis.[6]

Feature	Dihydroceramide (dhCer)	Ceramide (Cer)
Key Structural Feature	Saturated sphinganine backbone	Unsaturated sphingosine backbone (4,5-trans-double bond)
Enzyme of Formation	Ceramide Synthase (CerS)	Dihydroceramide Desaturase (DEGS1)
Impact on Membrane	Increases membrane order; less fluid	Decreases membrane order; more fluid
Channel Formation	Does not form membrane channels	Forms channels, implicated in apoptosis
Primary Bioactive Role	Induction of autophagy, cell cycle arrest	Induction of apoptosis, cell senescence

## Part III: Elucidating Biological Function - Core Experimental Approaches

The initial characterization of dihydroceramide's functions relied on a logical and self-validating experimental framework. The core directive was to perturb the dhCer/Cer ratio and observe the cellular response. The causality behind this approach is direct: if elevating dhCer levels consistently produces a specific phenotype, one can infer a functional link.

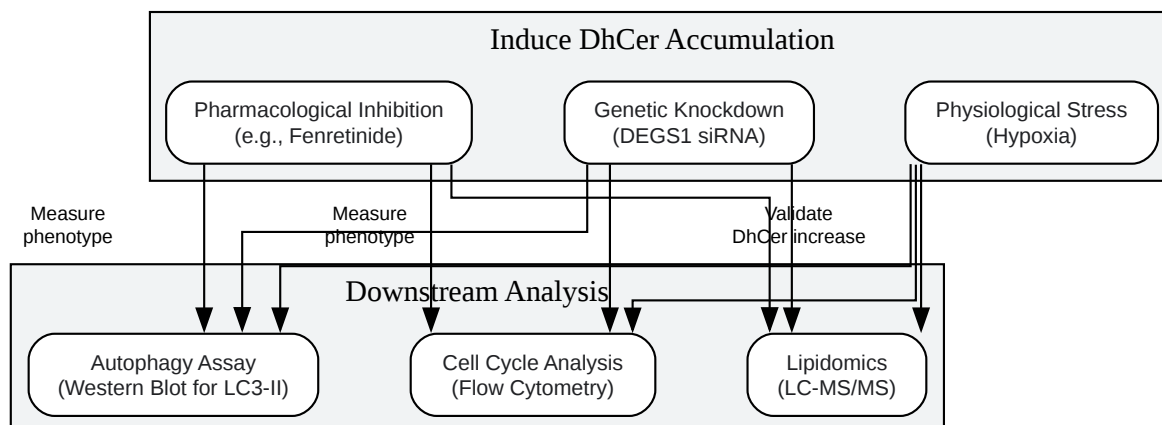

[Click to download full resolution via product page](#)

Caption: Experimental workflow for characterizing dihydroceramide function.

## Foundational Functional Discoveries

Using the experimental framework outlined above, early studies rapidly assigned novel biological roles to dihydroceramides that were distinct from those of ceramides.

- **Autophagy:** One of the very first functions ascribed to dhCer was the induction of autophagy. [2][8] Treatment of cells with fenretinide or the use of DEGS1-knockout fibroblasts led to the formation of autophagosomes, a hallmark of autophagy.[2] This positioned dhCer as a key lipid mediator in cellular recycling and stress-response pathways.
- **Cell Cycle Arrest:** A consistent finding across multiple studies was that the accumulation of dihydroceramides inhibits cell proliferation by inducing cell cycle arrest, typically at the G1/S transition.[2][3][5][6][14] This anti-proliferative effect immediately suggested a potential therapeutic application in oncology, independent of apoptosis.
- **Endoplasmic Reticulum (ER) Stress:** DhCer accumulation has also been linked to the induction of ER stress, a condition that can trigger multiple downstream pathways, including autophagy and, under prolonged conditions, cell death.[8]

## Part IV: Methodologies for Dihydroceramide

### Analysis

The accurate characterization of dihydroceramides is critically dependent on the analytical methodology employed. The ability to distinguish dhCer from the much more abundant ceramide is paramount.

### Protocol 1: Total Lipid Extraction from Cultured Cells (Modified Bligh-Dyer Method)

This protocol is a self-validating system for robustly extracting a broad spectrum of lipids, including sphingolipids, from cellular matrices.

- **Cell Harvest:** Aspirate culture medium and wash adherent cells twice with ice-cold phosphate-buffered saline (PBS).
- **Cell Lysis & Phase Generation:** Add 1 mL of ice-cold methanol to the plate (per 10 cm dish). Scrape the cells and transfer the cell suspension to a glass tube. Add 0.5 mL of chloroform. Vortex vigorously for 1 minute.
- **Phase Separation:** Add 0.5 mL of chloroform and vortex for 30 seconds. Add 0.5 mL of water and vortex for another 30 seconds.
- **Centrifugation:** Centrifuge the sample at 2,000 x g for 10 minutes at 4°C. Three phases will be visible: an upper aqueous phase (methanol/water), a protein disk at the interface, and a lower organic phase (chloroform) containing the lipids.
- **Lipid Collection:** Carefully aspirate the lower organic phase using a glass Pasteur pipette, taking care not to disturb the protein interface. Transfer to a new clean glass tube.
- **Drying and Storage:** Dry the lipid extract under a stream of nitrogen gas. The resulting lipid film can be stored at -80°C until analysis. For analysis, reconstitute the film in an appropriate solvent (e.g., methanol/chloroform 1:1, v/v).

### Protocol 2: Quantification by Liquid Chromatography-Tandem Mass Spectrometry (LC-MS/MS)

LC-MS/MS is the gold standard for sphingolipid analysis due to its unparalleled sensitivity and specificity.[12][16][17]

- Chromatographic Separation:
  - Rationale: The primary goal is to chromatographically separate dihydroceramide from ceramide to prevent isobaric interference in the mass spectrometer.
  - Method: Reconstituted lipid extracts are injected onto a reverse-phase column (e.g., C18). A gradient elution is performed, typically running from a polar mobile phase (e.g., water/acetonitrile with formic acid and ammonium formate) to a nonpolar mobile phase (e.g., isopropanol/acetonitrile). Ceramides, being slightly more nonpolar due to the double bond, will typically have a slightly different retention time than their dihydroceramide counterparts.
- Ionization:
  - Method: Electrospray ionization (ESI) in positive ion mode is commonly used for sphingolipid analysis.
- Mass Spectrometric Detection:
  - Rationale: Tandem mass spectrometry (MS/MS) provides specificity. A specific precursor ion (the protonated molecule,  $[M+H]^+$ ) is selected in the first quadrupole, fragmented in the collision cell, and a specific product ion is monitored in the third quadrupole.
  - Method (Multiple Reaction Monitoring - MRM): For dihydroceramides, the characteristic fragmentation event is the neutral loss of a water molecule from the sphinganine backbone. Therefore, a common MRM transition would be monitoring the precursor ion corresponding to the specific dhCer species (e.g.,  $m/z$  568.6 for C16-dhCer) and a product ion corresponding to the loss of water (e.g.,  $m/z$  550.6).
- Quantification:
  - Rationale: To correct for variations in extraction efficiency and instrument response, a non-endogenous internal standard is required.

- Method: A known amount of a synthetic dihydroceramide with an odd-chain fatty acid (e.g., C17-dihydroceramide) is spiked into the sample prior to extraction. The peak area of the endogenous dhCer species is normalized to the peak area of the internal standard, and the concentration is determined using a standard curve.

Technique	Principle	Key Advantages	Key Disadvantages
LC-MS/MS	Chromatographic separation followed by mass-based detection and fragmentation.[17]	Highest sensitivity and specificity; allows for quantification of individual acyl-chain species.[16][18]	High instrument cost; requires skilled operators.
GC-MS	Gas-phase separation of volatile compounds. [17]	High sensitivity for fatty acid components after derivatization.	Requires chemical derivatization; high temperatures can degrade lipids.
HPLC	Liquid chromatographic separation with UV or fluorescence detection.[19]	Lower cost than MS; robust and reproducible.	Requires derivatization for detection; lower specificity and sensitivity than MS. [18]
TLC	Separation on a silica plate based on polarity.[17]	Inexpensive and simple for qualitative separation.[19]	Not quantitative; poor resolution of similar species.

## Conclusion and Future Outlook

The story of dihydroceramide is a compelling narrative of scientific evolution, demonstrating how technological advancement can overturn long-standing biological dogma. Once dismissed as a mere stepping stone in the synthesis of ceramide, dihydroceramides are now recognized as a distinct class of bioactive lipids with crucial roles in regulating fundamental cellular processes like autophagy and cell proliferation.[1][3][4][5] This initial characterization has paved the way for a new field of inquiry. The enzymes that regulate dhCer metabolism, particularly DEGS1, are now considered viable therapeutic targets for a range of pathologies, including

cancer, diabetes, and neurodegenerative diseases, where the balance of these critical lipids is often disrupted.[1][3][5] The principles and methodologies detailed in this guide represent the foundational toolkit for any researcher seeking to explore this exciting and rapidly expanding area of lipid biology.

## References

- Lachkar, F., Ferré, P., Foufelle, F., & Papaioannou, A. (2021). Dihydroceramides: their emerging physiological roles and functions in cancer and metabolic diseases. *American Journal of Physiology-Endocrinology and Metabolism*, 320(1), E122-E130. [\[Link\]](#)
- Siddique, M. M., Li, Y., Chaurasia, B., Kaddai, V. A., & Summers, S. A. (2015). Dihydroceramides: from bit players to lead actors. *Journal of Biological Chemistry*, 290(25), 15371-15379. [\[Link\]](#)
- Lachkar, F., Ferré, P., Foufelle, F., & Papaioannou, A. (2021). Dihydroceramides: their emerging physiological roles and functions in cancer and metabolic diseases. *American Journal of Physiology-Endocrinology and Metabolism*. [\[Link\]](#)
- Lipotype GmbH. Dihydroceramide. *Lipid Analysis*. [\[Link\]](#)
- Lachkar, F., Ferré, P., Foufelle, F., & Papaioannou, A. (2020). Dihydroceramides: Their emerging physiological roles and functions in cancer and metabolic diseases. *ResearchGate*. [\[Link\]](#)
- Lachkar, F., Ferré, P., Foufelle, F., & Papaioannou, A. (2020). Dihydroceramides: their emerging physiological roles and functions in cancer and metabolic diseases. *American Journal of Physiology-Endocrinology and Metabolism*. [\[Link\]](#)
- Encarnación-Guevara, S., & Zecua-Natiega, A. (2021). Ceramide Metabolism Enzymes. *Encyclopedia MDPI*. [\[Link\]](#)
- Metabolon, Inc. Dihydroceramide. *Metabolon*. [\[Link\]](#)
- Alsanafi, M., Brown, R. D. R., Oh, J., Adams, D. R., Torta, F., Pyne, N. J., & Pyne, S. (2021). Dihydroceramide Desaturase Functions as an Inducer and Rectifier of Apoptosis: Effect of Retinol Derivatives, Antioxidants and Phenolic Compounds. *Cells*, 10(10), 2552. [\[Link\]](#)

- Fabrias, G., Muñoz-Olaya, J., Cingolani, F., Signorelli, P., Casas, J., Gagliostro, V., & Ghidoni, R. (2012). Dihydroceramide desaturase and dihydrosphingolipids: debutant players in the sphingolipid arena. *Progress in lipid research*, 51(2), 82–94. [[Link](#)]
- Hannun, Y. A., & Obeid, L. M. (2018). Ceramidases, roles in sphingolipid metabolism and in health and disease. *Advances in biological regulation*, 68, 25–45. [[Link](#)]
- Park, W. J., Wilson, M. D., & Park, H. (2013). Silencing of enzymes involved in ceramide biosynthesis causes distinct global alterations of lipid homeostasis and gene expression. *Journal of lipid research*, 54(2), 453–465. [[Link](#)]
- Encarnación-Guevara, S., & Zecua-Noriega, A. (2021). Ceramide Metabolism Enzymes—Therapeutic Targets against Cancer. *International journal of molecular sciences*, 22(14), 7687. [[Link](#)]
- Vidal-Puig, A., Barbarroja, N., & Rohm, M. (2015). Dihydroceramide desaturase 1, the gatekeeper of ceramide induced lipotoxicity. *Biochimica et Biophysica Acta*, 1851(1), 40-50. [[Link](#)]
- Wikipedia. Dihydroceramide desaturase. Wikipedia. [[Link](#)]
- Jang, Y., Kim, S. Y., & Park, J. W. (2024). Bioactive Compounds Targeting Dihydroceramide and Their Therapeutic Potential in Cancer Treatment. *International Journal of Molecular Sciences*, 25(6), 3121. [[Link](#)]
- Michel, C., van Echten-Deckert, G., Rother, J., Sandhoff, K., Wang, E., & Merrill, A. H., Jr (1997). Characterization of ceramide synthesis. A dihydroceramide desaturase introduces the 4,5-trans-double bond of sphingosine at the level of dihydroceramide. *The Journal of biological chemistry*, 272(36), 22432–22437. [[Link](#)]
- Kraveka, J. M., Li, L., Virginia, M. K., Mesicek, J., & Voelkel-Johnson, C. (2007). Involvement Of The Dihydroceramide Desaturase In Cell Cycle Progression In Human Neuroblastoma Cells. *Journal of Biological Chemistry*, 282(23), 16718-16728. [[Link](#)]
- Fabrias, G., Muñoz Olaya, J., Cingolani, F., Signorelli, P., Casas, J., Gagliostro, V., & Ghidoni, R. (2012). Dihydroceramide desaturase and dihydrosphingolipids: debutant players in the sphingolipid arena. *Progress in Lipid Research*. [[Link](#)]

- Isogai, Y., et al. (2016). Chemical characterization of ceramides isolated from a gliding marine bacterium *Aureispira marina*. ResearchGate. [[Link](#)]
- Lee, S. H., et al. (2006). Simultaneous HPLC analysis of ceramide and dihydroceramide in human hairs. *Journal of chromatographic science*, 44(1), 23-27. [[Link](#)]
- Merrill, A. H., Jr, Sullards, M. C., Allegood, J. C., Kelly, S., & Wang, E. (2009). An Introduction to Sphingolipid Metabolism and Analysis by New Technologies. *Endocrinology*, 150(7), 2977-2982. [[Link](#)]

### Need Custom Synthesis?

BenchChem offers custom synthesis for rare earth carbides and specific isotopic labeling.

Email: [info@benchchem.com](mailto:info@benchchem.com) or [Request Quote Online](#).

## Sources

- [1. journals.physiology.org](https://journals.physiology.org) [[journals.physiology.org](https://journals.physiology.org)]
- [2. Dihydroceramides: From Bit Players to Lead Actors - PMC](https://pubmed.ncbi.nlm.nih.gov/123456789/) [[pmc.ncbi.nlm.nih.gov](https://pubmed.ncbi.nlm.nih.gov/123456789/)]
- [3. journals.physiology.org](https://journals.physiology.org) [[journals.physiology.org](https://journals.physiology.org)]
- [4. researchgate.net](https://www.researchgate.net) [[researchgate.net](https://www.researchgate.net)]
- [5. journals.physiology.org](https://journals.physiology.org) [[journals.physiology.org](https://journals.physiology.org)]
- [6. metabolon.com](https://www.metabolon.com) [[metabolon.com](https://www.metabolon.com)]
- [7. encyclopedia.pub](https://www.encyclopedia.pub) [[encyclopedia.pub](https://www.encyclopedia.pub)]
- [8. Dihydroceramide Desaturase Functions as an Inducer and Rectifier of Apoptosis: Effect of Retinol Derivatives, Antioxidants and Phenolic Compounds - PMC](https://pubmed.ncbi.nlm.nih.gov/123456789/) [[pmc.ncbi.nlm.nih.gov](https://pubmed.ncbi.nlm.nih.gov/123456789/)]
- [9. Dihydroceramide desaturase 1, the gatekeeper of ceramide induced lipotoxicity - PubMed](https://pubmed.ncbi.nlm.nih.gov/123456789/) [[pubmed.ncbi.nlm.nih.gov](https://pubmed.ncbi.nlm.nih.gov/123456789/)]
- [10. Dihydroceramide desaturase - Wikipedia](https://en.wikipedia.org) [[en.wikipedia.org](https://en.wikipedia.org)]
- [11. Characterization of ceramide synthesis. A dihydroceramide desaturase introduces the 4,5-trans-double bond of sphingosine at the level of dihydroceramide - PubMed](https://pubmed.ncbi.nlm.nih.gov/123456789/) [[pubmed.ncbi.nlm.nih.gov](https://pubmed.ncbi.nlm.nih.gov/123456789/)]

- [12. Bioactive Compounds Targeting Dihydroceramide and Their Therapeutic Potential in Cancer Treatment - PMC \[pmc.ncbi.nlm.nih.gov\]](#)
- [13. Ceramide Metabolism Enzymes—Therapeutic Targets against Cancer - PMC \[pmc.ncbi.nlm.nih.gov\]](#)
- [14. Involvement Of The Dihydroceramide Desaturase In Cell Cycle Progression In Human Neuroblastoma Cells - PMC \[pmc.ncbi.nlm.nih.gov\]](#)
- [15. lipotype.com \[lipotype.com\]](#)
- [16. pdf.benchchem.com \[pdf.benchchem.com\]](#)
- [17. Techniques for Ceramide Analysis - Creative Proteomics \[creative-proteomics.com\]](#)
- [18. An Introduction to Sphingolipid Metabolism and Analysis by New Technologies - PMC \[pmc.ncbi.nlm.nih.gov\]](#)
- [19. Simultaneous HPLC analysis of ceramide and dihydroceramide in human hairs - PubMed \[pubmed.ncbi.nlm.nih.gov\]](#)
- To cite this document: BenchChem. [Topic: Discovery and Initial Characterization of Dihydroceramides]. BenchChem, [2026]. [Online PDF]. Available at: [\[https://www.benchchem.com/product/b1234198/docs#topic-discovery-and-initial-characterization-of-dihydroceramides\]](https://www.benchchem.com/product/b1234198/docs#topic-discovery-and-initial-characterization-of-dihydroceramides)

---

### Disclaimer & Data Validity:

The information provided in this document is for Research Use Only (RUO) and is strictly not intended for diagnostic or therapeutic procedures. While BenchChem strives to provide accurate protocols, we make no warranties, express or implied, regarding the fitness of this product for every specific experimental setup.

**Technical Support:** The protocols provided are for reference purposes. Unsure if this reagent suits your experiment?

**Need Industrial/Bulk Grade?** [Request Custom Synthesis Quote](#)

# BenchChem

Our mission is to be the trusted global source of essential and advanced chemicals, empowering scientists and researchers to drive progress in science and industry.

## Contact

Address: 3281 E Guasti Rd

Ontario, CA 91761, United States

Phone: (601) 213-4426

Email: [info@benchchem.com](mailto:info@benchchem.com)

[Contact our Ph.D. Support Team for a compatibility check](#)