

# The Emerging Role of pppApp in Bacterial Signaling: A Technical Guide

**Author:** BenchChem Technical Support Team. **Date:** April 2026

## Compound of Interest

Compound Name:	Pppapp
CAS No.:	53951-06-7
Cat. No.:	B1234930

[Get Quote](#)

An In-depth Examination of Adenosine 3',5'-bis(triphosphate) in the Stringent Response and Beyond

## Abstract

The bacterial stringent response, a crucial survival mechanism triggered by nutritional stress, has long been associated with the alarmones guanosine 3',5'-bis(diphosphate) (ppGpp) and guanosine 3',5'-bis(triphosphate) (pppGpp). However, recent discoveries have unveiled a parallel and, in some aspects, contrasting role for their adenosine analogs, particularly adenosine 3',5'-bis(triphosphate) (**pppApp**). This technical guide provides a comprehensive overview of the current understanding of **pppApp**'s function in bacterial physiology. It delves into the enzymatic synthesis and degradation of **pppApp**, its molecular targets, and its distinct regulatory effects on gene expression. This document is intended for researchers, scientists, and drug development professionals seeking a detailed understanding of this emerging player in bacterial signaling, with a focus on quantitative data, experimental methodologies, and the intricate signaling pathways involved.

## Introduction

The stringent response is a highly conserved bacterial stress response that enables adaptation to nutrient-limiting conditions. This response is primarily mediated by the accumulation of (p)ppGpp, which acts as a global regulator of transcription, translation, and other cellular processes. The discovery of (p)ppApp, and specifically **pppApp**, has added a new layer of complexity to our understanding of this critical signaling network. While structurally similar to (p)ppGpp, **pppApp** exhibits unique biochemical properties and physiological roles, sometimes acting in opposition to its guanosine counterpart. This guide will explore the multifaceted role of **pppApp**, from its synthesis by specialized enzymes to its impact on key cellular machinery.

## Synthesis and Degradation of pppApp

The intracellular concentration of **pppApp** is tightly controlled by the coordinated action of synthetases and hydrolases.

### pppApp Synthesis

The synthesis of **pppApp** is catalyzed by a class of enzymes known as (p)ppApp synthetases. These enzymes transfer a pyrophosphate group from a donor molecule, typically ATP, to the 3'-hydroxyl of an acceptor adenosine nucleotide.

Two prominent examples of enzymes capable of synthesizing **pppApp** are:

- **Tas1** (Type VI (p)ppApp Synthetase 1): A potent toxin delivered by the Type VI Secretion System (T6SS) in bacteria like *Pseudomonas aeruginosa*. Tas1 exhibits a remarkably high catalytic rate, efficiently converting ATP to **pppApp**, leading to rapid ATP depletion in target cells.[\[1\]\[2\]\[3\]\[4\]](#)
- **RSHMex** (RelA/SpoT Homolog from *Methylobacterium extorquens*): This enzyme displays a broader substrate specificity, capable of synthesizing both (p)ppGpp and **pppApp** in vitro.[\[1\]\[3\]\[5\]\[6\]\[7\]\[8\]](#)

The synthesis reaction can be summarized as follows:



### pppApp Degradation

The hydrolysis of **pppApp** is carried out by specific hydrolases, which are crucial for detoxifying cells from the effects of **pppApp**-synthesizing toxins and for potentially regulating endogenous **pppApp** levels. These enzymes, often referred to as (p)ppApp hydrolases, belong to the HD domain superfamily of metallohydrolases. An example is the SAH enzyme from *Pseudomonas aeruginosa*, which can hydrolyze both (p)ppGpp and (p)ppApp.[9]

## Molecular Targets and Mechanism of Action

**pppApp** exerts its physiological effects through direct interaction with key cellular components, leading to a cascade of downstream events.

### RNA Polymerase (RNAP)

A primary target of **pppApp** is the bacterial RNA polymerase. X-ray crystallography has revealed that (p)ppApp binds to *E. coli* RNAP near the active site and switch regions.[5] This interaction leads to a distinct transcriptional response compared to (p)ppGpp. Notably, while (p)ppGpp typically inhibits the transcription of ribosomal RNA (rRNA) promoters, such as *rrnB* P1, **pppApp** has been shown to activate transcription from this promoter.[3][5] This opposing effect highlights a "Yin-Yang" like regulatory plasticity of RNAP in response to different alarmones.[5] The presence of the transcription factor DksA can hinder the activating effect of **pppApp** at the *rrnB* P1 promoter.[5]

### Purine Biosynthesis Pathway

**pppApp**, along with ppApp, can directly inhibit enzymes involved in purine biosynthesis. One such target is PurF (glutamine phosphoribosylpyrophosphate amidotransferase), a key enzyme in the de novo purine synthesis pathway.[10] Both (p)ppApp and (p)ppGpp bind to and inhibit PurF, suggesting a shared mechanism for regulating nucleotide metabolism.[10][11]

### ATP Depletion

In the context of bacterial warfare, the rapid synthesis of **pppApp** by toxins like Tas1 leads to a drastic depletion of the cellular ATP pool.[1][2][3][4] This has widespread consequences, disrupting numerous essential metabolic pathways that are dependent on ATP and ultimately leading to target cell death.[1][2][3][4]

## Quantitative Data

The following tables summarize the available quantitative data on the kinetics of **pppApp**-related enzymes and its interaction with molecular targets.

Table 1: Kinetic Parameters of (p)ppApp Synthetases

Enzyme	Organism	Substrate	Apparent Km (mM)	kcat (s-1)	Reference
Tas1	Pseudomonas aeruginosa	ATP	-	~3000	[2]
RSHMex	Methylobacterium extorquens	ATP (for pppGpp synthesis)	~0.7	-	[3]
RSHMex	Methylobacterium extorquens	GTP (for pppGpp synthesis)	~2.5	-	[3]

Note: Kinetic data for **pppApp** synthesis by RSHMex is not fully characterized.

Table 2: Kinetic Parameters of (p)ppApp Hydrolases

Enzyme	Organism	Substrate	Hydrolysis Rate (molecules/min/enzyme)	Reference
Aph1	Bacteroides caccae	ppApp	~478	[12]
SAHMex	Methylobacterium extorquens	ppApp	~16	[12]

Table 3: Interaction of **pppApp** with Cellular Targets

Target	Organism	Ligand	Binding Affinity (Kd)	Inhibition (IC50/Ki)	Reference
PurF	Escherichia coli	pppApp	-	Similar to (p)ppGpp	[13]
RelA	Escherichia coli	ppApp	-	24.5 ± 3.5 μM (IC50)	[14]

Note: Direct binding affinity (Kd) of **pppApp** to E. coli RNA polymerase has not been quantitatively determined in the reviewed literature, though binding has been structurally and functionally demonstrated.[5]

## Experimental Protocols

This section provides detailed methodologies for key experiments used to study the role of **pppApp**.

### In Vitro Synthesis of pppApp

This protocol is adapted for the enzymatic synthesis of **pppApp** using a purified (p)ppApp synthetase like Tas1 or RSHMex.

Materials:

- Purified (p)ppApp synthetase (e.g., Tas1, RSHMex)
- ATP solution (e.g., 100 mM, pH 7.5)
- Reaction Buffer (e.g., 50 mM Tris-HCl pH 8.9, 10 mM MgCl<sub>2</sub> or 8 mM CoCl<sub>2</sub> for RSHMex)[3]
- Nuclease-free water

Procedure:

- Set up the reaction mixture in a microcentrifuge tube on ice:
  - Reaction Buffer (10X): 2 μL

- ATP (100 mM): 2  $\mu$ L
- Purified (p)ppApp synthetase (e.g., 1  $\mu$ M): 1  $\mu$ L
- Nuclease-free water: to a final volume of 20  $\mu$ L
- Mix gently by pipetting and centrifuge briefly to collect the contents.
- Incubate the reaction at 37°C for a desired time (e.g., 1-2 hours). The optimal time may need to be determined empirically.
- Stop the reaction by heat inactivation (e.g., 95°C for 5 minutes) or by adding EDTA to a final concentration of 50 mM.
- The synthesized **pppApp** can be purified using anion-exchange chromatography or HPLC.

## Quantification of pppApp by HPLC-MS

This protocol outlines a general procedure for the extraction and quantification of intracellular **pppApp** from bacterial cultures.

Materials:

- Bacterial culture
- Quenching solution (e.g., 60% methanol, -20°C)
- Extraction solvent (e.g., acetonitrile/methanol/water, 40:40:20, v/v/v, with 0.1 M formic acid, -20°C)
- HPLC system coupled to a mass spectrometer (e.g., HILIC-MS)[15]
- **pppApp** standard

Procedure:

- Harvesting and Quenching: Rapidly harvest bacterial cells from a defined volume of culture by centrifugation at 4°C. Immediately resuspend the cell pellet in ice-cold quenching solution to stop metabolic activity.

- Extraction: Centrifuge the quenched cells and discard the supernatant. Add the cold extraction solvent to the cell pellet. Vortex vigorously and incubate on ice for 30 minutes with intermittent vortexing.
- Clarification: Centrifuge the extract at maximum speed at 4°C for 10-15 minutes to pellet cell debris.
- Analysis: Transfer the supernatant to a new tube and analyze by HPLC-MS. Use a suitable chromatography method, such as Hydrophilic Interaction Liquid Chromatography (HILIC), for separation of polar metabolites like **pppApp**.<sup>[15]</sup>
- Quantification: Generate a standard curve using a purified **pppApp** standard to quantify the concentration in the bacterial extracts.

## In Vitro Transcription Assay

This protocol is designed to assess the effect of **pppApp** on transcription initiation from a specific promoter (e.g., *rrnB* P1).

Materials:

- Purified *E. coli* RNA polymerase holoenzyme ( $E\sigma 70$ )
- Linear DNA template containing the promoter of interest (e.g., *rrnB* P1)
- **pppApp** solution
- (p)ppGpp solution (for comparison)
- NTP mix (ATP, GTP, CTP, UTP)
- [ $\alpha$ -<sup>32</sup>P]-UTP for radiolabeling
- Transcription Buffer (e.g., 40 mM Tris-HCl pH 7.9, 100 mM KCl, 10 mM MgCl<sub>2</sub>, 1 mM DTT)
- Stop Solution (e.g., 95% formamide, 20 mM EDTA, loading dyes)

Procedure:

- Assemble the transcription reaction on ice:
  - Transcription Buffer (10X): 2  $\mu$ L
  - DNA template (e.g., 10 nM final): 1  $\mu$ L
  - **pppApp** or (p)ppGpp (at desired concentrations) or water: 2  $\mu$ L
  - E. coli RNAP holoenzyme (e.g., 50 nM final): 1  $\mu$ L
  - Nuclease-free water: to 18  $\mu$ L
- Incubate at 37°C for 15 minutes to allow for open complex formation.
- Initiate transcription by adding 2  $\mu$ L of NTP mix containing [ $\alpha$ -32P]-UTP.
- Incubate at 37°C for 10-15 minutes.
- Stop the reaction by adding an equal volume of Stop Solution.
- Denature the samples by heating at 95°C for 5 minutes.
- Separate the transcripts by denaturing polyacrylamide gel electrophoresis (PAGE).
- Visualize the radiolabeled transcripts using autoradiography or phosphorimaging and quantify the band intensities.

## Electrophoretic Mobility Shift Assay (EMSA)

This protocol is used to qualitatively assess the binding of **pppApp** to RNA polymerase and its effect on the formation of the RNAP-promoter complex.

Materials:

- Purified E. coli RNA polymerase holoenzyme (E $\sigma$ 70)
- Radiolabeled DNA probe containing the promoter of interest
- **pppApp** solution

- Binding Buffer (e.g., 20 mM Tris-HCl pH 7.9, 50 mM KCl, 1 mM DTT, 5% glycerol)
- Native polyacrylamide gel
- TBE buffer

Procedure:

- Set up the binding reactions in microcentrifuge tubes on ice:
  - Binding Buffer (5X): 2  $\mu$ L
  - Radiolabeled DNA probe (e.g., 1 nM final): 1  $\mu$ L
  - **pppApp** (at desired concentrations) or water: 2  $\mu$ L
  - E. coli RNAP holoenzyme (at desired concentrations): 1  $\mu$ L
  - Nuclease-free water: to a final volume of 10  $\mu$ L
- Incubate at room temperature for 20-30 minutes to allow binding to reach equilibrium.
- Add loading dye (without SDS or denaturing agents).
- Load the samples onto a pre-run native polyacrylamide gel.
- Run the gel at a constant voltage in a cold room or with a cooling system.
- Dry the gel and visualize the bands by autoradiography or phosphorimaging. A shift in the mobility of the radiolabeled probe indicates the formation of a protein-DNA complex.

## Signaling Pathways and Logical Relationships

The following diagrams illustrate the key signaling pathways and experimental workflows involving **pppApp**.

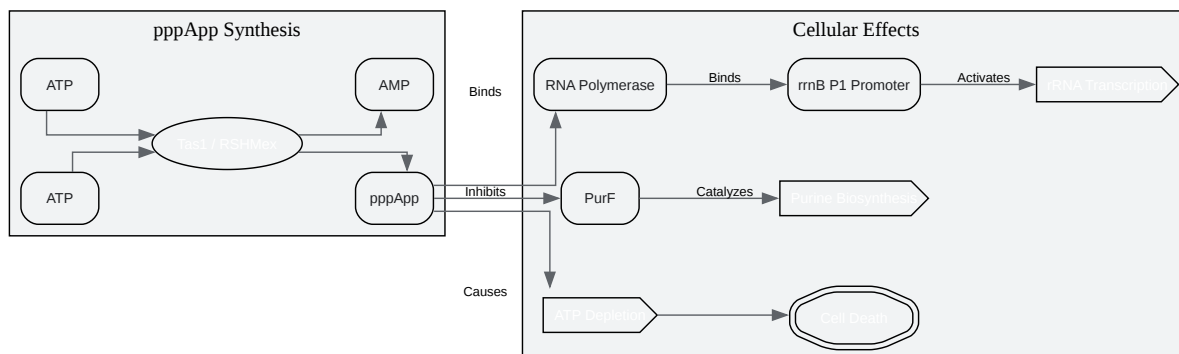

[Click to download full resolution via product page](#)

Caption: Signaling pathway of **pppApp** synthesis and its cellular effects.

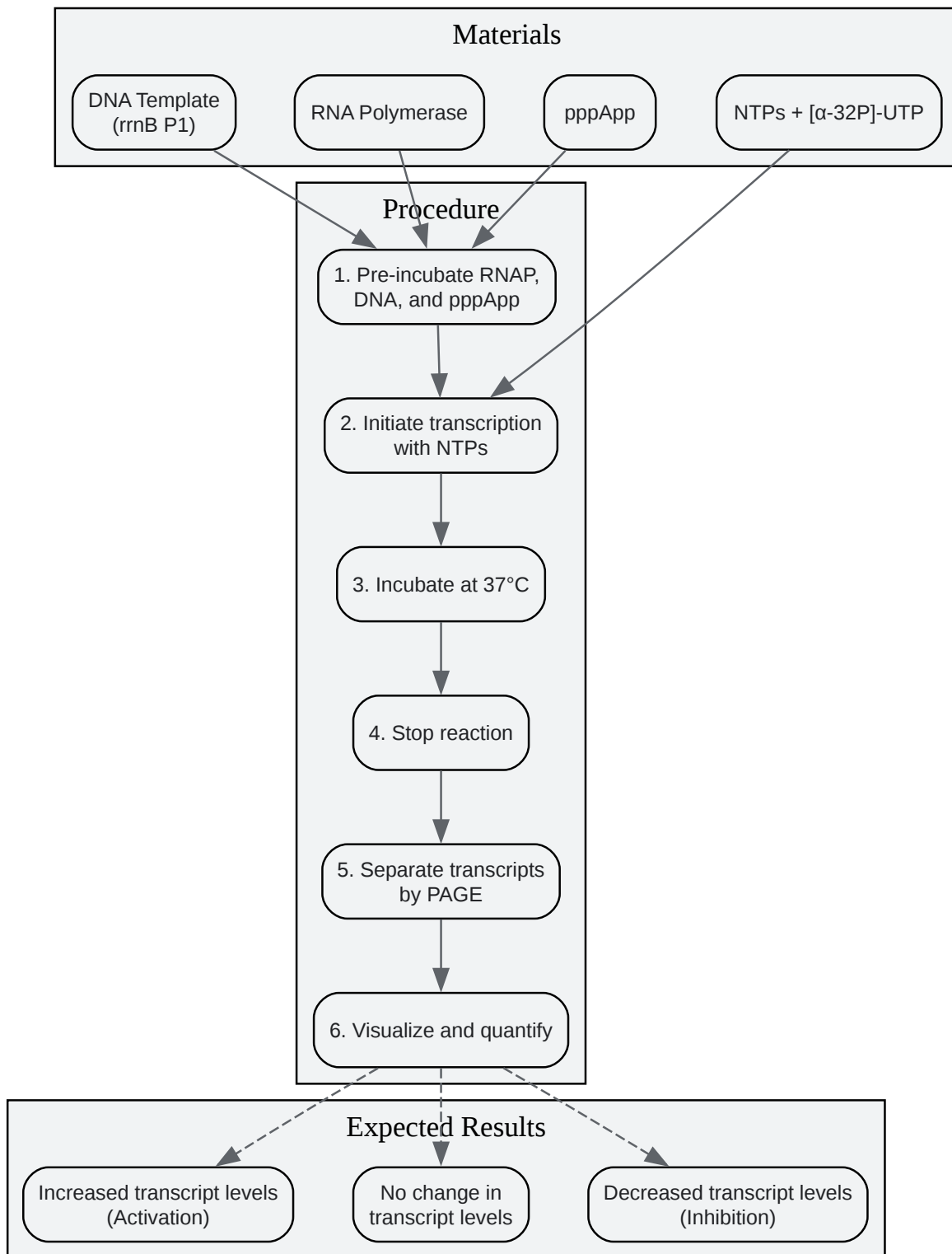

[Click to download full resolution via product page](#)

Caption: Experimental workflow for an in vitro transcription assay.

## Conclusion and Future Directions

The discovery of **pppApp** as a signaling molecule has opened new avenues of research in bacterial physiology and intercellular communication. Its distinct and sometimes opposing roles compared to (p)ppGpp suggest a more nuanced and complex regulatory network than previously appreciated. While significant progress has been made in identifying the enzymes that synthesize and degrade **pppApp** and in characterizing its primary targets, many questions remain. Future research should focus on:

- Elucidating the endogenous role of **pppApp**: While its function as a toxin is well-established, the physiological relevance of endogenously produced **pppApp** in non-conflict situations needs further investigation.
- Identifying additional **pppApp** targets: A comprehensive understanding of the **pppApp** regulon will require the identification of all its cellular binding partners.
- Exploring the interplay between **pppApp** and (p)ppGpp signaling: The co-existence of these two alarmones raises questions about how their signals are integrated to produce a coherent cellular response.
- Developing specific inhibitors of **pppApp** synthesis: Such molecules could serve as valuable research tools and potentially as novel antimicrobial agents that disarm pathogenic bacteria.

A deeper understanding of the role of **pppApp** in the bacterial stringent response and other cellular processes will undoubtedly provide new insights into bacterial adaptation and survival, and may reveal novel targets for therapeutic intervention.

### *Need Custom Synthesis?*

*BenchChem offers custom synthesis for rare earth carbides and specific isotopic labeling.*

*Email: [info@benchchem.com](mailto:info@benchchem.com) or [Request Quote Online](#).*

## References

- [1. Structure-function comparisons of \(p\)ppApp vs \(p\)ppGpp for Escherichia coli RNA polymerase binding sites and for rrnB P1 promoter regulatory responses in vitro - PMC](#)

[[pmc.ncbi.nlm.nih.gov](https://pubmed.ncbi.nlm.nih.gov)]

- 2. Structure-function comparisons of (p)ppApp vs (p)ppGpp for Escherichia coli RNA polymerase binding sites and for rrnB P1 promoter regulatory responses in vitro - PubMed [[pubmed.ncbi.nlm.nih.gov](https://pubmed.ncbi.nlm.nih.gov)]
- 3. Frontiers | Methylobacterium extorquens RSH Enzyme Synthesizes (p)ppGpp and pppApp in vitro and in vivo, and Leads to Discovery of pppApp Synthesis in Escherichia coli [[frontiersin.org](https://frontiersin.org)]
- 4. Still looking for the magic spot: the crystallographically-defined binding site for ppGpp on RNA polymerase is unlikely to be responsible for rRNA transcription regulation - PMC [[pmc.ncbi.nlm.nih.gov](https://pubmed.ncbi.nlm.nih.gov)]
- 5. [researchgate.net](https://researchgate.net) [[researchgate.net](https://researchgate.net)]
- 6. (p)ppGpp: Magic Modulators of Bacterial Physiology and Metabolism - PMC [[pmc.ncbi.nlm.nih.gov](https://pubmed.ncbi.nlm.nih.gov)]
- 7. ppGpp binding to a site at the RNAP-DksA interface accounts for its dramatic effects on transcription initiation during the stringent response - PMC [[pmc.ncbi.nlm.nih.gov](https://pubmed.ncbi.nlm.nih.gov)]
- 8. Methylobacterium extorquens RSH Enzyme Synthesizes (p)ppGpp and pppApp in vitro and in vivo, and Leads to Discovery of pppApp Synthesis in Escherichia coli - PubMed [[pubmed.ncbi.nlm.nih.gov](https://pubmed.ncbi.nlm.nih.gov)]
- 9. [researchgate.net](https://researchgate.net) [[researchgate.net](https://researchgate.net)]
- 10. Electrophoretic Mobility Shift Assay (EMSA) for Detecting Protein-Nucleic Acid Interactions - PMC [[pmc.ncbi.nlm.nih.gov](https://pubmed.ncbi.nlm.nih.gov)]
- 11. [dspace.mit.edu](https://dspace.mit.edu) [[dspace.mit.edu](https://dspace.mit.edu)]
- 12. [pnas.org](https://pnas.org) [[pnas.org](https://pnas.org)]
- 13. [researchgate.net](https://researchgate.net) [[researchgate.net](https://researchgate.net)]
- 14. Frontiers | (p)ppGpp: Magic Modulators of Bacterial Physiology and Metabolism [[frontiersin.org](https://frontiersin.org)]
- 15. How to quantify magic spots - a brief overview of (p)ppGpp detection and quantitation methods - PMC [[pmc.ncbi.nlm.nih.gov](https://pubmed.ncbi.nlm.nih.gov)]
- To cite this document: BenchChem. [The Emerging Role of pppApp in Bacterial Signaling: A Technical Guide]. BenchChem, [2026]. [Online PDF]. Available at: [<https://www.benchchem.com/product/b1234930/docs#the-emerging-role-of-pppapp-in-bacterial-signaling-a-technical-guide>]

**Disclaimer & Data Validity:**

The information provided in this document is for Research Use Only (RUO) and is strictly not intended for diagnostic or therapeutic procedures. While BenchChem strives to provide accurate protocols, we make no warranties, express or implied, regarding the fitness of this product for every specific experimental setup.

**Technical Support:** The protocols provided are for reference purposes. Unsure if this reagent suits your experiment?

**Need Industrial/Bulk Grade?** [Request Custom Synthesis Quote](#)

## BenchChem

Our mission is to be the trusted global source of essential and advanced chemicals, empowering scientists and researchers to drive progress in science and industry.

### Contact

Address: 3281 E Guasti Rd  
Ontario, CA 91761, United States  
Phone: (601) 213-4426  
Email: [info@benchchem.com](mailto:info@benchchem.com)

[Contact our Ph.D. Support Team for a compatibility check](#)