

# Technical Support Center: Troubleshooting KAAD-Cyclopamine's Limited Bioavailability

**Author:** BenchChem Technical Support Team. **Date:** April 2026

## Compound of Interest

Compound Name: KAAD-Cyclopamine

Cat. No.: B1234132

[Get Quote](#)

Welcome to the technical support center for **KAAD-Cyclopamine**. This resource is designed to assist researchers, scientists, and drug development professionals in overcoming the challenges associated with the limited bioavailability of this potent Hedgehog signaling inhibitor. Here you will find troubleshooting guides and frequently asked questions to help you optimize your in vitro and in vivo experiments.

## Frequently Asked Questions (FAQs)

Q1: What is **KAAD-cyclopamine** and why is it used?

A1: **KAAD-cyclopamine** is a semi-synthetic derivative of cyclopamine, a naturally occurring steroidal alkaloid.[1] It is a highly potent antagonist of the Smoothed (Smo) receptor, a key component of the Hedgehog (Hh) signaling pathway.[2] By inhibiting Smo, **KAAD-cyclopamine** effectively blocks the Hh pathway, which is aberrantly activated in several types of cancers.[3] Its increased potency—10 to 20 times greater than the parent compound, cyclopamine—makes it a valuable tool for cancer research.[1]

Q2: I'm seeing good in vitro results, but my in vivo experiments with **KAAD-cyclopamine** are showing limited efficacy. What could be the reason?

A2: This is a common challenge. The parent compound, cyclopamine, is known for its poor oral bioavailability, suboptimal pharmacokinetics, and low metabolic stability.[1] While **KAAD-cyclopamine** has improved potency, its inherent hydrophobicity can still lead to poor absorption and rapid clearance in vivo. To achieve therapeutic concentrations at the target site, it is often necessary to employ formulation strategies to enhance its bioavailability.

Q3: How should I prepare a stock solution of **KAAD-cyclopamine**?

A3: **KAAD-cyclopamine** is a solid that is soluble in organic solvents. For in vitro assays, it is recommended to prepare a stock solution in DMSO at a concentration of 5 mg/mL. For long-term storage, it is advisable to aliquot the stock solution and store it at -80°C for up to 6 months. When stored at -20°C, the solution is stable for about a month. Avoid repeated freeze-thaw cycles.

Q4: What are the main strategies to improve the bioavailability of **KAAD-cyclopamine**?

A4: The primary strategies to overcome the limited bioavailability of hydrophobic drugs like **KAAD-cyclopamine** fall into three main categories:

- **Liposomal Formulations:** Encapsulating **KAAD-cyclopamine** within lipid bilayers can improve its solubility, protect it from premature metabolism, and enhance its circulation time.
- **Nanoparticle Formulations:** Loading **KAAD-cyclopamine** into polymeric nanoparticles or solid lipid nanoparticles can increase its surface area for dissolution and facilitate its transport across biological membranes.
- **Solid Dispersions:** Dispersing **KAAD-cyclopamine** in a water-soluble carrier at a solid state can significantly improve its dissolution rate.

Each of these approaches has its own advantages and is suited for different experimental needs and routes of administration.

## Troubleshooting Guide: Enhancing In Vivo Bioavailability

This guide provides a structured approach to addressing the common issue of limited in vivo efficacy of **KAAD-cyclopamine** due to its poor bioavailability.

## Problem: Limited or inconsistent tumor growth inhibition in animal models despite proven in vitro activity.

### Possible Cause 1: Poor Solubility and Precipitation upon Administration

- Troubleshooting Step: Before in vivo administration, visually inspect the diluted formulation for any signs of precipitation. If using an aqueous vehicle, the hydrophobic nature of **KAAD-cyclopamine** can cause it to crash out of solution.
- Solution: Utilize a formulation strategy to improve solubility. Refer to the experimental protocols below for preparing liposomal, nanoparticle, or solid dispersion formulations.

### Possible Cause 2: Rapid Metabolism and Clearance

- Troubleshooting Step: If possible, perform a pilot pharmacokinetic (PK) study to determine the concentration of **KAAD-cyclopamine** in plasma over time. A rapid decrease in concentration suggests rapid clearance. The parent compound, cyclopamine, has a terminal elimination half-life of about 4 hours in mice when administered intraperitoneally or orally.
- Solution: Encapsulation strategies like liposomes and nanoparticles can shield the drug from metabolic enzymes and reduce clearance rates, thereby increasing its plasma half-life.

### Possible Cause 3: Inefficient Delivery to the Tumor Site

- Troubleshooting Step: Analyze the biodistribution of your formulation. If the drug is not accumulating in the tumor tissue at a sufficient concentration, its therapeutic effect will be limited.
- Solution: Nanoparticle-based formulations can take advantage of the Enhanced Permeability and Retention (EPR) effect for passive tumor targeting. For active targeting, ligands specific to tumor cell surface receptors can be conjugated to the surface of liposomes or nanoparticles.

## Data Presentation

The following tables summarize key properties of **KAAD-cyclopamine** and provide a representative comparison of expected pharmacokinetic parameters following different formulation strategies.

Table 1: Physicochemical and In Vitro Properties of **KAAD-Cyclopamine**

Property	Value	Reference
Molecular Weight	697.99 g/mol	
Appearance	White to light yellow solid	
Solubility	DMSO: 5 mg/mL	
Ethanol: 1 mg/mL		
Methanol: 1 mg/mL		
IC <sub>50</sub> (Shh-LIGHT2 assay)	~20 nM	
IC <sub>50</sub> (Purmorphamine-induced)	~3 nM	

Table 2: Representative Pharmacokinetic Parameters of Cyclopamine and Expected Improvements with **KAAD-Cyclopamine** Formulations

Formulation	Cmax (Peak Plasma Concentration)	Tmax (Time to Peak Concentration)	AUC (Area Under the Curve)	Expected Bioavailability Improvement
Cyclopamine (Oral Gavage in Mice)	Low	Variable	Low	Baseline
KAAD-Cyclopamine (Unformulated)	Low	Short	Low	Marginal improvement over cyclopamine
KAAD-Cyclopamine (Liposomal)	Moderate	Moderate	Moderate-High	Significant
KAAD-Cyclopamine (Nanoparticle)	Moderate-High	Moderate	High	Significant to High
KAAD-Cyclopamine (Solid Dispersion)	High	Short	High	High

Note: The data for formulated **KAAD-cyclopamine** are illustrative and represent the expected outcomes based on the principles of drug delivery. Actual values will depend on the specific formulation and experimental conditions.

## Experimental Protocols

Protocol 1: Preparation of **KAAD-Cyclopamine** Loaded Liposomes (Thin-Film Hydration Method)

- Lipid Film Preparation:
  - Dissolve **KAAD-cyclopamine** and a suitable lipid mixture (e.g., DSPC:Cholesterol:DSPE-PEG2000 in a 55:40:5 molar ratio) in chloroform in a round-bottom flask.

- Remove the organic solvent using a rotary evaporator under vacuum at a temperature above the lipid transition temperature to form a thin, uniform lipid film on the flask wall.
- Place the flask under high vacuum for at least 2 hours to remove any residual solvent.
- Hydration:
  - Hydrate the lipid film with a suitable aqueous buffer (e.g., phosphate-buffered saline, pH 7.4) by gentle rotation at a temperature above the lipid transition temperature. This will result in the formation of multilamellar vesicles (MLVs).
- Size Reduction:
  - To obtain small unilamellar vesicles (SUVs), subject the MLV suspension to probe sonication on ice or extrusion through polycarbonate membranes of a defined pore size (e.g., 100 nm).
- Purification:
  - Remove any unencapsulated **KAAD-cyclopamine** by size exclusion chromatography or dialysis.
- Characterization:
  - Determine the particle size and zeta potential using dynamic light scattering (DLS).
  - Quantify the encapsulation efficiency by lysing the liposomes with a suitable solvent (e.g., methanol) and measuring the drug concentration using HPLC.

#### Protocol 2: Preparation of **KAAD-Cyclopamine** Loaded Polymeric Nanoparticles (Emulsification-Solvent Evaporation Method)

- Organic Phase Preparation:
  - Dissolve **KAAD-cyclopamine** and a biodegradable polymer (e.g., PLGA) in a water-immiscible organic solvent (e.g., dichloromethane or ethyl acetate).
- Emulsification:

- Add the organic phase to an aqueous solution containing a surfactant (e.g., polyvinyl alcohol - PVA) under high-speed homogenization or sonication to form an oil-in-water (o/w) emulsion.
- Solvent Evaporation:
  - Stir the emulsion at room temperature under constant magnetic stirring for several hours to allow the organic solvent to evaporate. This will lead to the precipitation of the polymer and the formation of solid nanoparticles.
- Washing and Collection:
  - Collect the nanoparticles by centrifugation.
  - Wash the nanoparticles several times with deionized water to remove excess surfactant and unencapsulated drug.
  - Lyophilize the nanoparticles to obtain a dry powder for long-term storage.
- Characterization:
  - Determine the particle size and morphology using DLS and scanning electron microscopy (SEM).
  - Calculate the drug loading and encapsulation efficiency by dissolving a known amount of nanoparticles in a suitable solvent and quantifying the drug content via HPLC.

### Protocol 3: Preparation of **KAAD-Cyclopamine** Solid Dispersion (Solvent Evaporation Method)

- Solution Preparation:
  - Dissolve **KAAD-cyclopamine** and a hydrophilic carrier (e.g., polyvinylpyrrolidone K30 - PVP K30 or polyethylene glycol 6000 - PEG 6000) in a common volatile solvent (e.g., methanol or ethanol). The drug-to-carrier ratio should be optimized (e.g., 1:5 or 1:10 w/w).
- Solvent Evaporation:
  - Evaporate the solvent using a rotary evaporator to obtain a solid mass.

- Dry the solid mass further in a vacuum oven at a suitable temperature to remove any residual solvent.
- Milling and Sieving:
  - Pulverize the dried solid mass using a mortar and pestle.
  - Pass the resulting powder through a sieve to obtain a uniform particle size.
- Characterization:
  - Assess the solid-state properties of the dispersion using Differential Scanning Calorimetry (DSC) and X-ray Diffraction (XRD) to confirm the amorphous nature of the drug.
  - Perform in vitro dissolution studies to compare the dissolution rate of the solid dispersion with that of the pure drug.

## Mandatory Visualizations

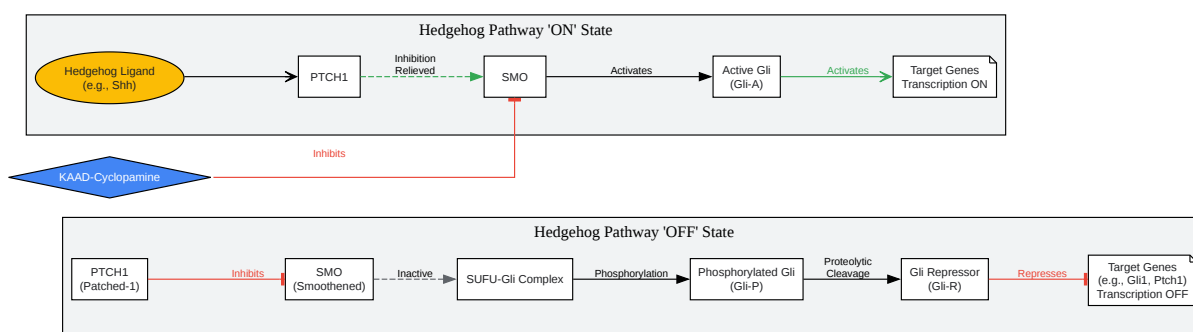

[Click to download full resolution via product page](#)



[Click to download full resolution via product page](#)

Caption: Experimental workflow for selecting and optimizing a formulation to enhance **KAAD-Cyclopamine** bioavailability.

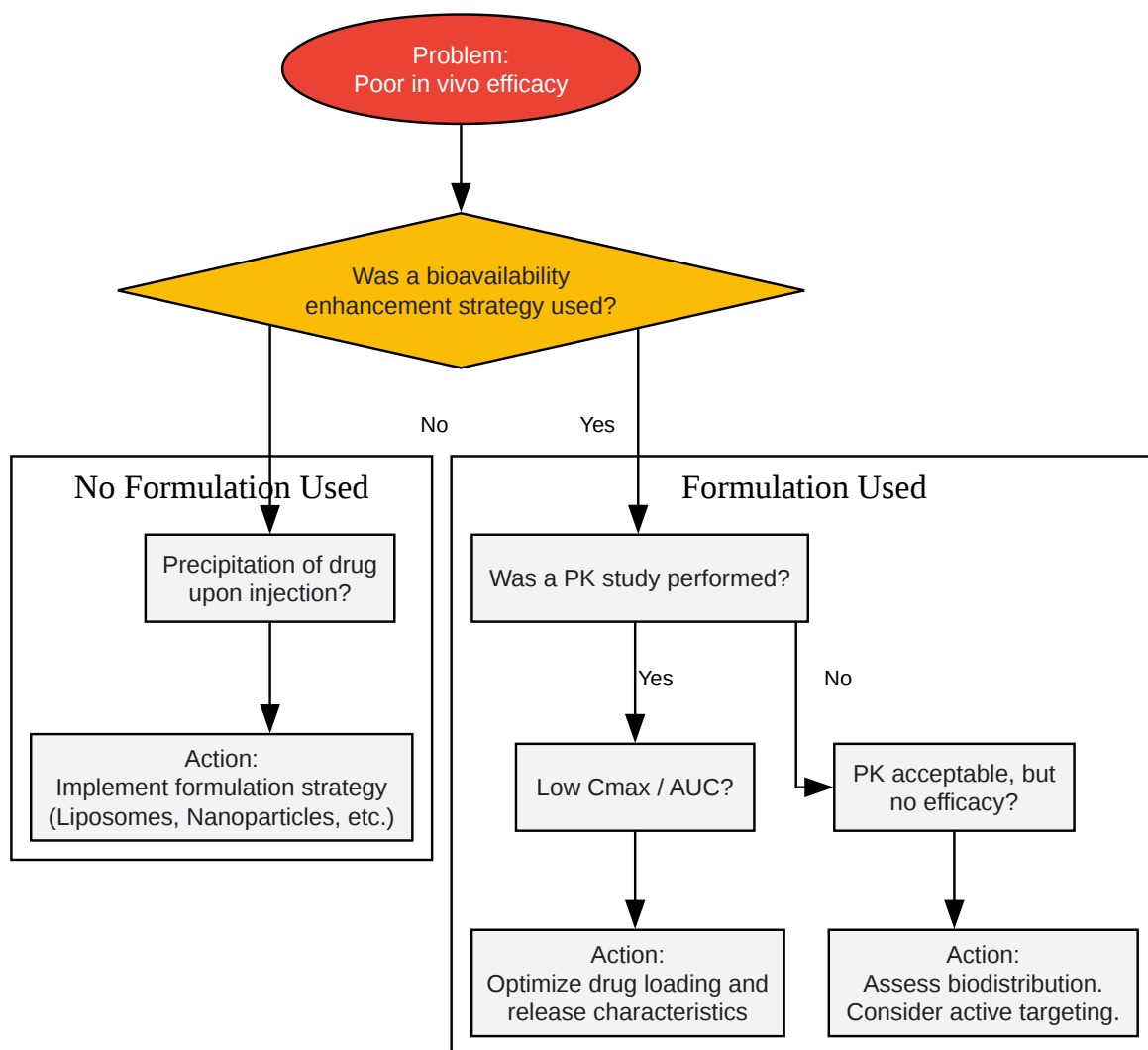

[Click to download full resolution via product page](#)

Caption: A decision tree for troubleshooting the limited in vivo bioavailability of **KAAD-Cyclopamine**.

### Need Custom Synthesis?

BenchChem offers custom synthesis for rare earth carbides and specific isotopic labeling.

Email: [info@benchchem.com](mailto:info@benchchem.com) or [Request Quote Online](#).

## References

- 1. [chm.bris.ac.uk](http://chm.bris.ac.uk) [[chm.bris.ac.uk](http://chm.bris.ac.uk)]
- 2. [medchemexpress.com](http://medchemexpress.com) [[medchemexpress.com](http://medchemexpress.com)]
- 3. [mdpi.com](http://mdpi.com) [[mdpi.com](http://mdpi.com)]
- To cite this document: BenchChem. [Technical Support Center: Troubleshooting KAAD-Cyclopamine's Limited Bioavailability]. BenchChem, [2026]. [Online PDF]. Available at: [<https://www.benchchem.com/product/b1234132/docs#technical-support-center-troubleshooting-kaad-cyclopamine-s-limited-bioavailability>]

### Disclaimer & Data Validity:

The information provided in this document is for Research Use Only (RUO) and is strictly not intended for diagnostic or therapeutic procedures. While BenchChem strives to provide accurate protocols, we make no warranties, express or implied, regarding the fitness of this product for every specific experimental setup.

**Technical Support:** The protocols provided are for reference purposes. Unsure if this reagent suits your experiment?

**Need Industrial/Bulk Grade?** [Request Custom Synthesis Quote](#)

## BenchChem

Our mission is to be the trusted global source of essential and advanced chemicals, empowering scientists and researchers to drive progress in science and industry.

### Contact

Address: 3281 E Guasti Rd

Ontario, CA 91761, United States

Phone: (601) 213-4426

Email: [info@benchchem.com](mailto:info@benchchem.com)

Contact our Ph.D. Support Team for a compatibility check