

Comparative Assessment of DOTAP Immunogenicity: A Technical Guide

Author: BenchChem Technical Support Team. **Date:** May 2026

Compound of Interest

Compound Name: *Dotap mesylate, 98*

Cat. No.: *B12331317*

[Get Quote](#)

Executive Summary: The Dual Nature of DOTAP

In the landscape of lipid-based delivery, DOTAP (1,2-dioleoyl-3-trimethylammonium-propane) occupies a polarized position. Unlike ionizable lipids (e.g., SM-102, ALC-0315) used in FDA-approved mRNA vaccines which remain neutral in circulation, DOTAP maintains a permanent positive charge.

This physicochemical characteristic creates a "Double-Edged Sword" profile:

- For Gene Therapy (Defect): The permanent charge attracts serum opsonins, triggering rapid clearance and systemic inflammation (toxicity), limiting its utility for systemic protein replacement.
- For Immuno-Oncology (Feature): DOTAP acts as a potent Th1-biasing adjuvant. It activates innate immunity via TLR4 and ROS pathways, making it an ideal carrier for cancer vaccines where antigen cross-presentation to CD8+ T cells is required.

This guide provides the framework to objectively assess DOTAP's immunogenicity against its alternatives.

Mechanistic Basis of Immunogenicity

To assess immunogenicity, one must measure the specific signaling pathways DOTAP activates. Unlike neutral lipids, DOTAP is not inert. It functions as a Danger-Associated Molecular Pattern (DAMP) mimetic.

Key Pathways

- **TLR4 Activation:** DOTAP stimulates Toll-Like Receptor 4 (TLR4), triggering the MyD88-dependent pathway leading to NF-

B activation and pro-inflammatory cytokine release (TNF-

, IL-6).
- **ROS Induction:** The cationic headgroup disrupts endosomal membranes, generating Reactive Oxygen Species (ROS). This oxidative stress activates the NLRP3 inflammasome.
- **ERK/MAPK:** DOTAP induces phosphorylation of ERK, contributing to dendritic cell (DC) maturation.

Visualization: The DOTAP Signaling Cascade

The following diagram illustrates the intracellular cascade triggered by DOTAP uptake.

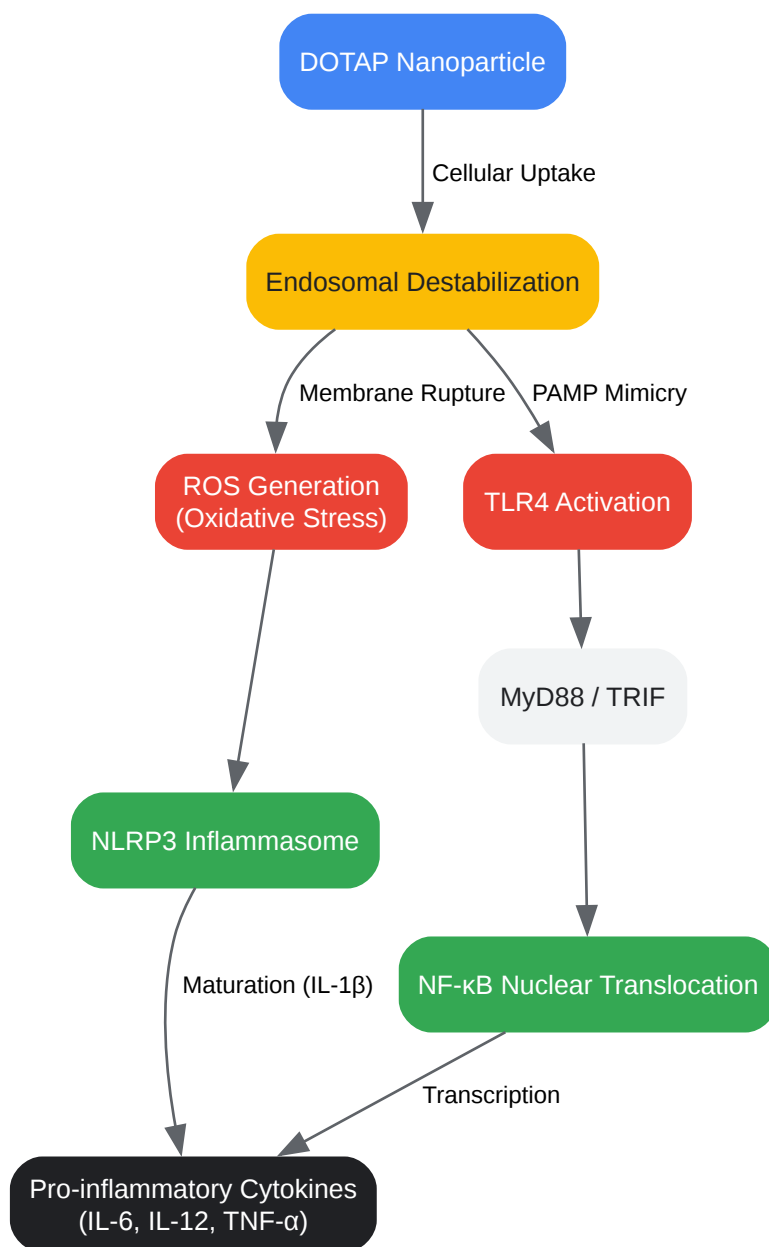

[Click to download full resolution via product page](#)

Caption: Figure 1.[1] DOTAP activates innate immunity via dual TLR4/MyD88 signaling and ROS-mediated inflammasome activation, leading to Th1 cytokine production.

Comparative Landscape

When justifying the use of DOTAP, it must be benchmarked against neutral and ionizable alternatives.

Table 1: Immunogenic Profile Comparison

| Feature | DOTAP (Cationic) | Ionizable Lipids (e.g., MC3) | Neutral Lipids (DOPC/Chol) | PEI (Polymer) |
|--------------------|----------------------------------|------------------------------|----------------------------|-------------------------|
| Charge @ pH 7.4 | Positive (+) | Neutral (0) | Neutral (0) | Positive (+) |
| Mechanism of Entry | Electrostatic Interaction | ApoE-mediated uptake | Passive / Fusion | Proton Sponge Effect |
| TLR Activation | High (TLR4) | Low/Moderate | Negligible | High (TLR4/5) |
| Cytokine Profile | Th1 Bias (IL-12, IFN- γ) | Mixed / Low | None | General Inflammation |
| Systemic Toxicity | High (Lung accumulation) | Low (Liver targeted) | Very Low | High (Cytotoxic) |
| Primary Use Case | Vaccine Adjuvant | mRNA Delivery (Systemic) | Control / Depot | Transfection (In Vitro) |

Experimental Protocols: The Self-Validating System

To publish a robust assessment, you must prove that the observed immunogenicity is intrinsic to the lipid and not due to endotoxin (LPS) contamination.

Phase A: Quality Control (The "Go/No-Go" Step)

Before any cell work, the formulation must pass the LPS Discrimination Test.

- LAL Assay: Measure endotoxin levels. Note: Cationic lipids can interfere with LAL. Use a chromogenic LAL kit with a diazo-coupling modification.
- Polymyxin B Control: In your cell assays, include a condition with Polymyxin B (an LPS inhibitor).
 - If signal drops with Polymyxin B: You have contamination.

- If signal persists: The immunogenicity is intrinsic to DOTAP.

Phase B: In Vitro Dendritic Cell (DC) Activation Assay

This protocol measures the adjuvant potential of DOTAP.

Materials:

- Murine Bone Marrow-Derived DCs (BMDCs) or Human PBMCs.
- Flow Cytometry Antibodies: CD11c, CD80, CD86, MHC-II.
- ELISA Kits: IL-6, IL-12p70, TNF-

Step-by-Step Workflow:

- Differentiation: Culture bone marrow cells in GM-CSF (20 ng/mL) for 6-8 days to generate immature DCs.
- Seeding: Plate
cells/well in 96-well plates.
- Treatment:
 - Negative Control: PBS/Neutral Liposomes (DOPC).
 - Positive Control: LPS (100 ng/mL).
 - Test Group: DOTAP Liposomes (dose titration: 1, 10, 50 M).
 - Specificity Control: DOTAP + Polymyxin B.
- Incubation: 24 hours at 37°C.
- Analysis:

- Supernatant: Collect for ELISA (Cytokines).
- Cells: Stain for maturation markers (CD80/86) and analyze via Flow Cytometry.

Visualization: Experimental Workflow

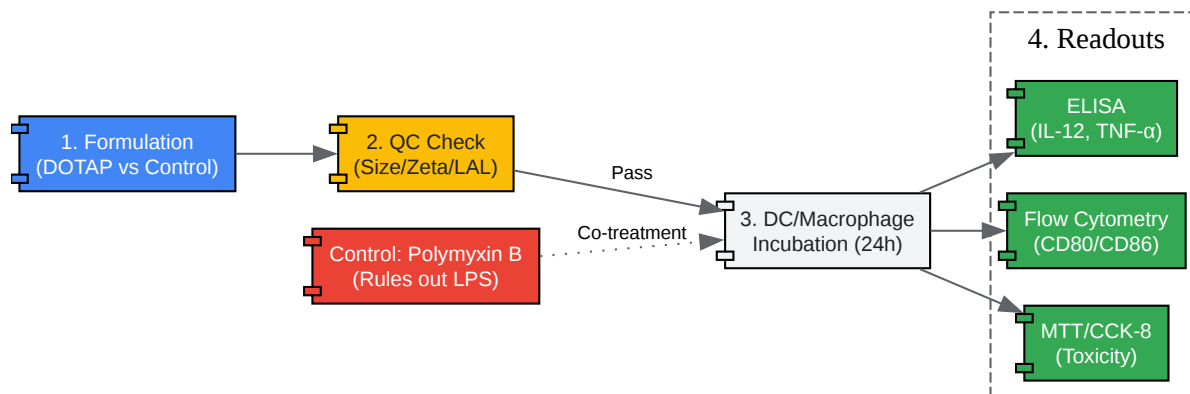

[Click to download full resolution via product page](#)

Caption: Figure 2. Self-validating workflow ensuring differentiation between lipid-mediated immunogenicity and endotoxin contamination.

Data Interpretation & Reporting

When publishing your data, categorize results into Toxicity vs. Adjuvanticity.

The "Cytokine Storm" Threshold (Toxicity)

High levels of TNF-

and IL-6 within 4 hours of administration suggest acute toxicity.

- DOTAP Behavior: Expect dose-dependent increases.
- Mitigation: PEGylation (adding PEG-Lipids) shields the positive charge, reducing this signal, but also reducing transfection efficiency [1].

The Th1 Bias (Adjuvanticity)

Successful DOTAP vaccination is marked by high IL-12 and IFN-

- Comparison: Neutral lipids will show near-zero levels.
- Significance: This profile drives CD8+ T-cell expansion, essential for tumor clearance [2].

In Vivo Antibody Isotyping

If testing in mice (e.g., BALB/c), analyze the IgG1 vs. IgG2a ratio.

- IgG1: Indicates Th2 response (Humoral).
- IgG2a: Indicates Th1 response (Cellular).
- DOTAP Result: Typically shifts ratio toward IgG2a, confirming its role as a Th1 adjuvant [3].

References

- Optimization of DOTAP/chol Cationic Lipid Nanoparticles for mRNA, pDNA, and Oligonucleotide Delivery. Source: AAPS PharmSciTech (2022). Context: Discusses the trade-off between PEGylation, toxicity, and transfection efficiency.[2] URL:[[Link](#)]
- Immunogenicity Testing of Lipidoids In Vitro and In Silico: Modulating Lipidoid-Mediated TLR4 Activation by Nanoparticle Design. Source: Molecular Therapy: Nucleic Acids (2018). Context: Mechanistic comparison of DOTAP vs. Lipidoids regarding TLR4 activation. URL: [[Link](#)]
- Intrinsic immunogenicity of liposomes for tuberculosis vaccines: Effect of cationic lipid and cholesterol. Source: Scholarly Publications Leiden University (2024). Context: Detailed analysis of DOTAP's intrinsic adjuvant properties and Th1 biasing. URL:[[Link](#)]
- In Vitro Immunogenicity Assays for Evaluating Generic Peptide Drug Products. Source: FDA.gov. Context: Regulatory perspective on innate immune response assessment assays. URL:[[Link](#)]

Need Custom Synthesis?

BenchChem offers custom synthesis for rare earth carbides and specific isotopic labeling.

Email: info@benchchem.com or [Request Quote Online](#).

Sources

- [1. Structure and Function of Cationic and Ionizable Lipids for Nucleic Acid Delivery - PMC \[pmc.ncbi.nlm.nih.gov\]](#)
- [2. Optimization of DOTAP/chol Cationic Lipid Nanoparticles for mRNA, pDNA, and Oligonucleotide Delivery - PMC \[pmc.ncbi.nlm.nih.gov\]](#)
- To cite this document: BenchChem. [Comparative Assessment of DOTAP Immunogenicity: A Technical Guide]. BenchChem, [2026]. [Online PDF]. Available at: [\[https://www.benchchem.com/product/b12331317/docs#comparative-assessment-of-dotap-immunogenicity-a-technical-guide\]](https://www.benchchem.com/product/b12331317/docs#comparative-assessment-of-dotap-immunogenicity-a-technical-guide)

Disclaimer & Data Validity:

The information provided in this document is for Research Use Only (RUO) and is strictly not intended for diagnostic or therapeutic procedures. While BenchChem strives to provide accurate protocols, we make no warranties, express or implied, regarding the fitness of this product for every specific experimental setup.

Technical Support: The protocols provided are for reference purposes. Unsure if this reagent suits your experiment?

Need Industrial/Bulk Grade? [Request Custom Synthesis Quote](#)

BenchChem

Our mission is to be the trusted global source of essential and advanced chemicals, empowering scientists and researchers to drive progress in science and industry.

Contact

Address: 3281 E Guasti Rd

Ontario, CA 91761, United States

Phone: (601) 213-4426

Email: info@benchchem.com

[Contact our Ph.D. Support Team for a compatibility check](#)