

# Technical Support Center: Gamma Spectroscopy of Bismuth-214

**Author:** BenchChem Technical Support Team. **Date:** April 2026

## Compound of Interest

Compound Name: *Bismuth-214*

CAS No.: *14733-03-0*

Cat. No.: *B1233251*

[Get Quote](#)

Welcome to the technical support center for gamma-ray spectroscopy analysis of **Bismuth-214** (Bi-214) and its progeny. This resource provides troubleshooting guides and frequently asked questions (FAQs) to assist researchers, scientists, and drug development professionals in resolving common issues related to peak resolution during their experiments.

## Frequently Asked Questions (FAQs) & Troubleshooting Guides

### Q1: Why am I observing poor peak resolution for Bi-214 gamma lines in my spectrum?

Poor peak resolution in gamma spectroscopy, particularly with High-Purity Germanium (HPGe) detectors, can stem from several factors related to the detector itself, the electronics, or the experimental setup.<sup>[1]</sup> The primary causes include:

- **Detector-Related Issues:** The intrinsic resolution of an HPGe detector is a function of its crystal quality, geometry, and operating conditions.<sup>[1]</sup> Since Germanium has a low band gap, detectors must be cooled to liquid nitrogen temperatures (77K) to reduce the thermal

generation of charge carriers, which otherwise introduces noise and degrades resolution.[2] Incomplete charge collection or variations in charge collection time (ballistic deficit), especially in larger detectors, can also lead to poor resolution and distorted peak shapes.[3]

- **Electronic Noise:** The overall resolution is a combination of detector effects and electronic noise.[2] This noise can originate from the preamplifier, detector leakage current, or external sources like ground loops and vibration (microphonics).[3][4]
- **Improper Amplifier Settings:** The spectroscopy amplifier shapes the signal from the preamplifier. Suboptimal settings for parameters like shaping time can significantly impact resolution. A shaping time that is too short may not allow for complete charge collection, while one that is too long can increase susceptibility to certain types of noise.[4]
- **High Count Rates:** At high activities or close source-to-detector geometries, high count rates can lead to pulse pile-up, where two pulses arrive too close in time to be distinguished. This distorts the spectrum and degrades resolution.[3]
- **Calibration Drift:** Changes in ambient temperature or high voltage instability can cause the gain of the system to drift, shifting peak positions and potentially broadening them over the course of a long acquisition.[5]

Table 1: Troubleshooting Summary for Poor Peak Resolution

Symptom	Potential Cause	Recommended Solution
All peaks are broad	Detector not properly cooled	Ensure the HPGe detector is cooled to its operating temperature (typically 77K with liquid nitrogen).[2]
Improper amplifier shaping time	Optimize the shaping time constant. Refer to Protocol 2.[4]	
High electronic noise/ground loop	Check all cable connections and grounding. Use a pulser to measure electronic noise contribution.[3][4]	
Peak Tailing (low-energy side)	Ballistic deficit, charge trapping	Increase amplifier shaping time. Use digital signal processing with a ballistic deficit correction if available.[3]
Neutron damage to detector crystal	Perform annealing of the detector (contact manufacturer) or apply software-based peak shape corrections.[6]	
Peak Tailing (high-energy side)	Pulse pile-up	Increase the source-to-detector distance to reduce the count rate.[3]
Shifting peak positions	Gain drift (temperature, HV)	Allow the system to stabilize before starting measurements. Use spectrum stabilization software if available.[5]
Overlapping peaks	Insufficient system resolution	Verify that an HPGe detector is being used, as they provide significantly better resolution than scintillators like NaI(Tl). Optimize all system

parameters (cooling,  
electronics).

---

## Q2: My peaks for Bi-214 (e.g., 609.3 keV) and its precursor Lead-214 (e.g., 351.9 keV) are overlapping or poorly defined. How can I improve their separation?

**Bismuth-214** is part of the Uranium-238 decay series and is preceded by Lead-214 (Pb-214). [7][8] When analyzing samples where the decay chain is in equilibrium, you will see gamma lines from both isotopes.[9] Resolving their characteristic peaks is crucial for accurate quantification.

The key to separating adjacent peaks is to maximize the energy resolution of your spectroscopy system. HPGe detectors are essential for this task due to their superior resolution compared to scintillation detectors.[4]

Steps to Improve Peak Separation:

- **Verify Detector Performance:** Ensure your HPGe detector is performing optimally. The resolution is typically specified as the Full Width at Half Maximum (FWHM) for the 1332.5 keV peak of Cobalt-60 and should be close to the manufacturer's specifications (e.g., < 2.0 keV).
- **Optimize Electronics:** Fine-tune the spectroscopy amplifier settings, particularly the shaping time, to achieve the best possible FWHM for your specific detector and count rate.[10] Refer to Protocol 2 for a detailed methodology.
- **Perform Accurate Energy Calibration:** A precise energy calibration is vital for correctly identifying peaks. Use a multi-point calibration source that covers a wide energy range. Refer to Protocol 1.[11]
- **Reduce Compton Background:** The Compton continuum from higher-energy gamma rays (like the 1764.5 keV and 2614.5 keV peaks from Bi-214 and Tl-208, respectively) can obscure lower-energy peaks.[9][12] Proper shielding with high-Z materials like lead can reduce background from external sources.

- Use Appropriate Peak Fitting Software: Modern gamma spectroscopy software uses sophisticated algorithms to deconvolve overlapping peaks. Ensure your software's peak fitting routine is correctly configured to handle complex multiplets.[\[13\]](#)[\[14\]](#)

Table 2: Prominent Gamma Energies for Bi-214 and Pb-214

Isotope	Energy (keV)	Intensity (%)	Notes
Pb-214	295.2	18.2	Often a key peak for Pb-214 quantification. <a href="#">[12]</a>
Pb-214	351.9	35.1	The most intense Pb-214 peak; crucial to resolve. <a href="#">[12]</a>
Bi-214	609.3	45.5	One of the most prominent Bi-214 peaks. <a href="#">[12]</a>
Bi-214	1120.3	14.9	Useful for confirmation. <a href="#">[12]</a>
Bi-214	1764.5	15.1	High-energy peak, often used for quantification. <a href="#">[12]</a>

### Q3: What are the optimal Multi-Channel Analyzer (MCA) and amplifier settings for high-resolution analysis of Bi-214?

Optimizing your data acquisition electronics is a critical step. The goal is to convert the charge pulse from the detector into a stable, well-shaped voltage pulse for the MCA to analyze.

#### Amplifier Settings:

- Gain (Coarse and Fine): Adjust the gain so that the highest energy gamma-ray of interest (e.g., the 2614.5 keV peak from Tl-208 in the decay chain) falls within the upper channels of

your MCA range (e.g., around channel 3000 of a 4096-channel spectrum).[15] This ensures you utilize the full resolution of the Analog-to-Digital Converter (ADC).

- **Shaping Time (Rise Time):** This is the most critical parameter for resolution. It represents a trade-off: longer shaping times generally yield better resolution by allowing for more complete charge collection but limit the maximum count rate the system can handle without pile-up.[3] For high-resolution HPGe work, typical shaping times range from 3 to 6  $\mu$ s.[10] The optimal value should be determined experimentally (see Protocol 2).
- **Pole-Zero (PZ) Cancellation:** Incorrect PZ settings can cause pulse undershoot or overshoot, which degrades resolution, especially at high count rates. The PZ should be adjusted to ensure the pulse returns to baseline as quickly as possible without crossing it.[15]

#### MCA/ADC Settings:

- **Conversion Gain (Channels):** Select the number of channels to match your desired energy range and resolution. For resolving complex spectra like those containing Bi-214 and its progeny, 4096 (4k) or 8192 (8k) channels are common.[16]
- **Lower-Level Discriminator (LLD):** Set the LLD just above the electronic noise floor to prevent the system from processing noise pulses, which increases dead time unnecessarily.

Table 3: Typical Amplifier and MCA Settings for High-Resolution Spectroscopy

Parameter	Typical Setting	Purpose
Amplifier		
Gain	As needed	Distribute peaks across the full channel range of the MCA.
Shaping Time	3 - 6 $\mu$ s	Optimize the trade-off between resolution and count rate capability.[10]
Pole-Zero	Adjusted for flat baseline	Prevent pulse undershoot/overshoot.[15]
MCA/ADC		
Conversion Gain	4096 or 8192 channels	Provide sufficient channels per peak for accurate analysis.
LLD	~50-100 keV	Exclude low-energy electronic noise from the spectrum.

## Experimental Protocols

### Protocol 1: Energy Calibration of an HPGe Spectrometer

Objective: To establish an accurate relationship between MCA channel number and gamma-ray energy.

Materials:

- Calibrated multi-isotope gamma reference source (e.g., containing  $^{137}\text{Cs}$ ,  $^{60}\text{Co}$ ,  $^{241}\text{Am}$ ).
- HPGe detector system with preamplifier, amplifier, and MCA.
- Spectroscopy software.

Procedure:

- System Setup: Power on all electronic components and allow the system to warm up and stabilize for at least 30 minutes. Ensure the HPGe detector is at its stable operating

temperature.[5]

- Source Placement: Place the calibration source in a reproducible position in front of the detector. A common distance is 10-25 cm from the detector endcap.
- Acquire Spectrum: Begin data acquisition. Collect counts until the primary photopeaks of the calibration source are well-defined with low statistical uncertainty (typically >10,000 counts in the smallest peak of interest).[11]
- Identify Peaks: Stop the acquisition. Using the spectroscopy software, identify the channel number corresponding to the centroid of at least three to four prominent, well-separated photopeaks from your calibration source. For example, use  $^{60}\text{Co}$  (1173.2 keV, 1332.5 keV) and  $^{137}\text{Cs}$  (661.7 keV).[11]
- Generate Calibration Curve: Use the software's energy calibration function. Enter the known energy and measured channel number for each identified peak.[11] The software will perform a linear or quadratic fit to the data points, creating a calibration equation ( $\text{Energy} = m * \text{Channel} + c$ ).
- Verify Calibration: Check the quality of the fit. The software should report a low residual error. Examine the calibrated spectrum to ensure known background peaks, such as  $^{40}\text{K}$  (1460.8 keV), appear at the correct energy.[16]

## Protocol 2: Optimizing Amplifier Shaping Time for Peak Resolution

Objective: To experimentally determine the amplifier shaping time that provides the best energy resolution (lowest FWHM) for a given detector.

Materials:

- Gamma source with a well-defined, isolated peak (e.g.,  $^{60}\text{Co}$ ).
- HPGe detector system and associated electronics.
- Oscilloscope.

- Spectroscopy software capable of FWHM measurement.

## Procedure:

- Initial Setup: Connect the amplifier output to both the MCA and an oscilloscope. Place the  $^{60}\text{Co}$  source in front of the detector to achieve a moderate count rate.
- Set Initial Shaping Time: Select the shortest shaping time available on the amplifier (e.g., 0.5  $\mu\text{s}$ ).
- Adjust Pole-Zero: Observe the amplifier output pulse on the oscilloscope. Adjust the Pole-Zero (PZ) setting until the pulse returns to the baseline quickly with no overshoot or undershoot.[15]
- Acquire and Analyze: Acquire a spectrum long enough to obtain a clear 1332.5 keV peak. Use the software to measure the FWHM of this peak. Record the shaping time and the corresponding FWHM.
- Iterate: Increase the shaping time to the next available setting (e.g., 1.0  $\mu\text{s}$ , 2.0  $\mu\text{s}$ , etc.). Re-adjust the PZ if necessary. Acquire a new spectrum and record the FWHM for the 1332.5 keV peak.
- Repeat: Continue this process for all available shaping times on the amplifier (e.g., up to 10 or 12  $\mu\text{s}$ ).
- Determine Optimum: Plot the measured FWHM as a function of shaping time. The optimal shaping time is the one that corresponds to the minimum FWHM value. This is typically in the range of 3-6  $\mu\text{s}$  for coaxial HPGe detectors.[10] Select this value for subsequent experiments.

## Mandatory Visualizations



[Click to download full resolution via product page](#)

Caption: Uranium-238 decay chain highlighting the path to **Bismuth-214**.

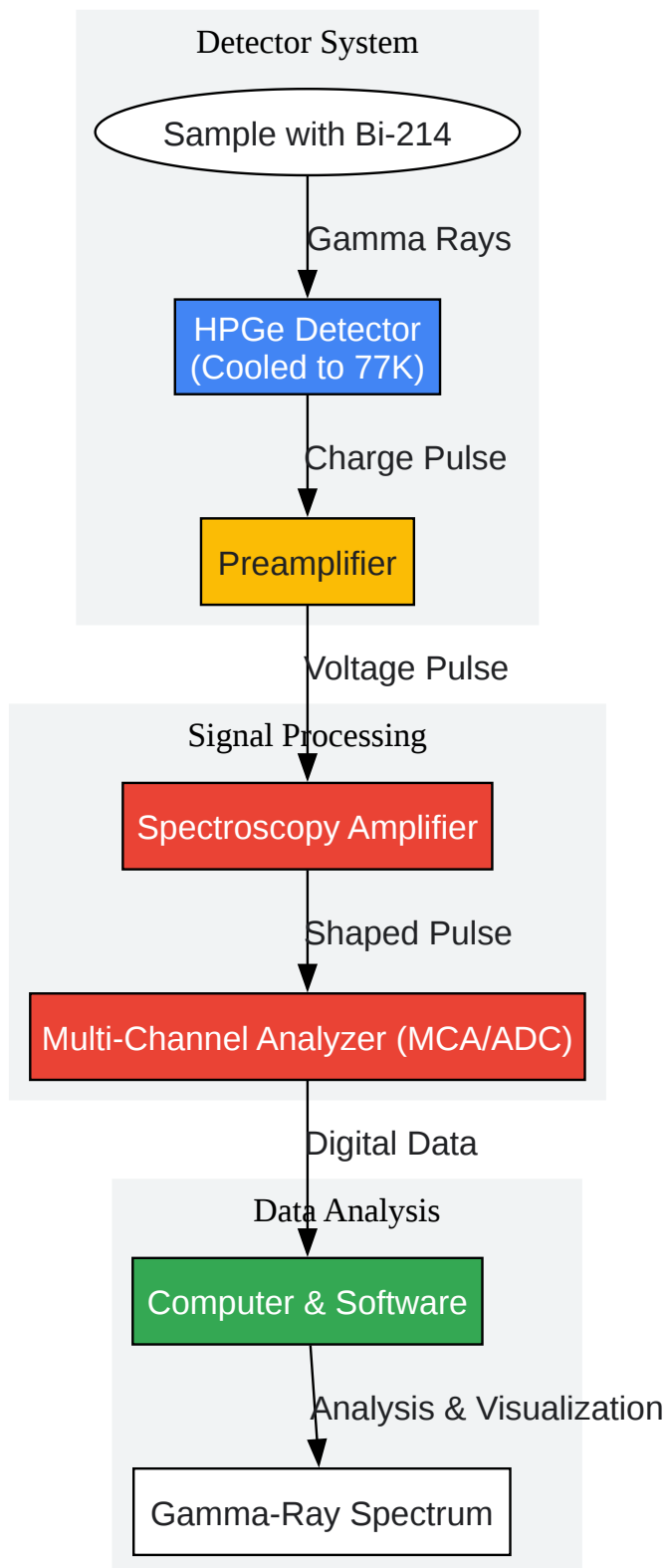

[Click to download full resolution via product page](#)

Caption: Standard experimental workflow for gamma-ray spectroscopy.

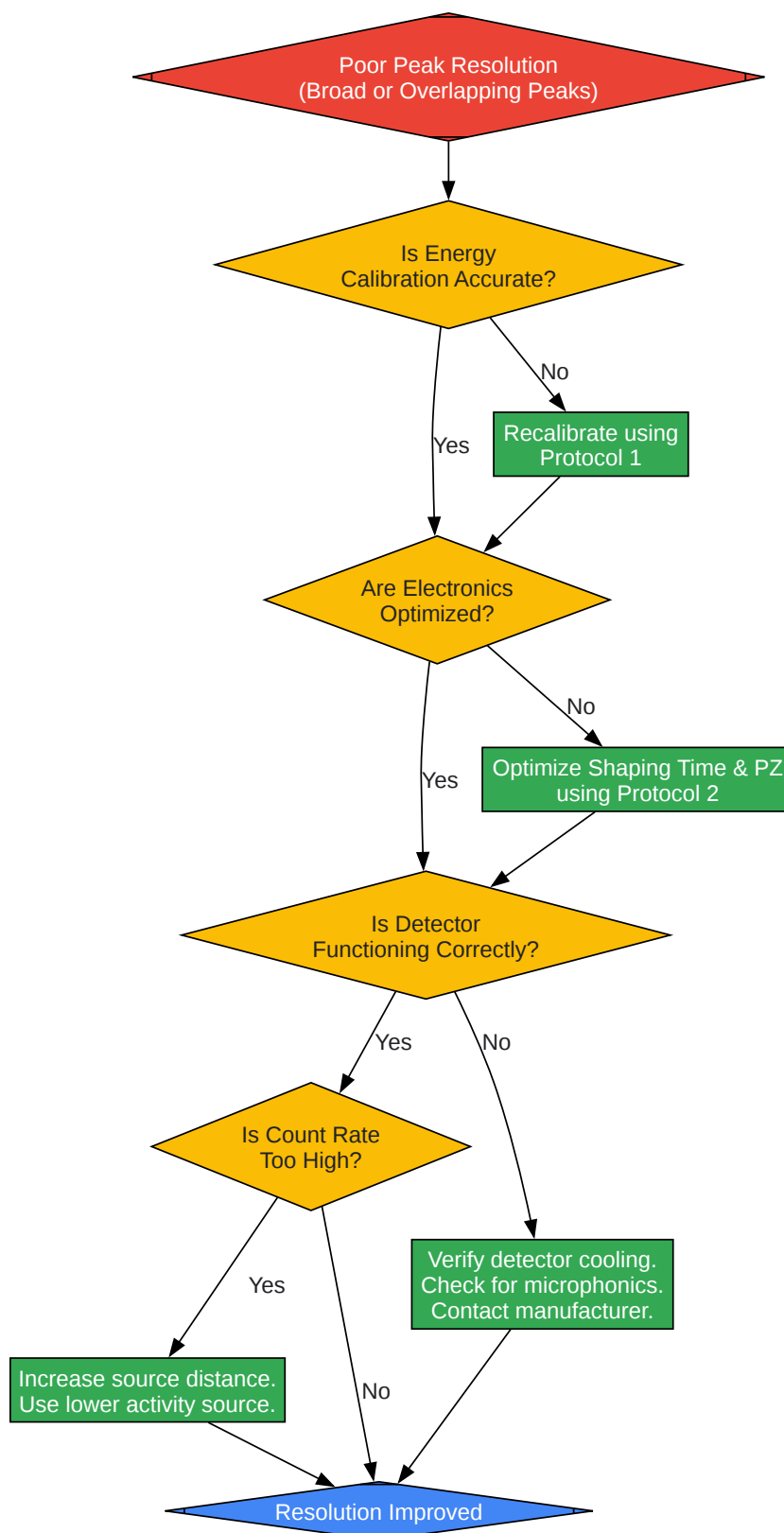

[Click to download full resolution via product page](#)

Caption: Logical troubleshooting flowchart for poor peak resolution.

### Need Custom Synthesis?

BenchChem offers custom synthesis for rare earth carbides and specific isotopic labeling.

Email: [info@benchchem.com](mailto:info@benchchem.com) or [Request Quote Online](#).

## References

- [1. ortec-online.com](https://www.ortec-online.com) [ortec-online.com]
- [2. mirion.com](https://www.mirion.com) [mirion.com]
- [3. ortec-online.com](https://www.ortec-online.com) [ortec-online.com]
- [4. ortec-online.com](https://www.ortec-online.com) [ortec-online.com]
- [5. docs.medusa-radiometrics.com](https://docs.medusa-radiometrics.com) [docs.medusa-radiometrics.com]
- [6. researchgate.net](https://www.researchgate.net) [researchgate.net]
- [7. radiacode.com](https://www.radiacode.com) [radiacode.com]
- [8. radiacode.com](https://www.radiacode.com) [radiacode.com]
- [9. theremino.com](https://www.theremino.com) [theremino.com]
- [10. ijesi.org](https://www.ijesi.org) [ijesi.org]
- [11. cdn.prod.web.uta.edu](https://cdn.prod.web.uta.edu) [cdn.prod.web.uta.edu]
- [12. researchgate.net](https://www.researchgate.net) [researchgate.net]
- [13. researchgate.net](https://www.researchgate.net) [researchgate.net]
- [14. Analytical peak fitting for gamma-ray spectrum analysis with Ge detectors](https://inis.iaea.org) [inis.iaea.org]
- [15. 122.physics.ucdavis.edu](https://122.physics.ucdavis.edu) [122.physics.ucdavis.edu]
- [16. phys.vt.edu](https://phys.vt.edu) [phys.vt.edu]
- To cite this document: BenchChem. [Technical Support Center: Gamma Spectroscopy of Bismuth-214]. BenchChem, [2026]. [Online PDF]. Available at: [\[https://www.benchchem.com/product/b1233251/docs#technical-support-center-gamma-spectroscopy-of-bismuth-214\]](https://www.benchchem.com/product/b1233251/docs#technical-support-center-gamma-spectroscopy-of-bismuth-214)

---

### Disclaimer & Data Validity:

The information provided in this document is for Research Use Only (RUO) and is strictly not intended for diagnostic or therapeutic procedures. While BenchChem strives to provide accurate protocols, we make no warranties, express or implied, regarding the fitness of this product for every specific experimental setup.

**Technical Support:** The protocols provided are for reference purposes. Unsure if this reagent suits your experiment?

**Need Industrial/Bulk Grade?** [Request Custom Synthesis Quote](#)

## BenchChem

Our mission is to be the trusted global source of essential and advanced chemicals, empowering scientists and researchers to drive progress in science and industry.

### Contact

Address: 3281 E Guasti Rd  
Ontario, CA 91761, United States  
Phone: (601) 213-4426  
Email: [info@benchchem.com](mailto:info@benchchem.com)

[Contact our Ph.D. Support Team for a compatibility check](#)