

Technical Monograph: 2-Hydroxynonanoic Acid

Author: BenchChem Technical Support Team. **Date:** May 2026

Compound of Interest

Compound Name: 2-Hydroxynonanoic acid

CAS No.: 70215-04-2

Cat. No.: B1233570

[Get Quote](#)

Chemical Architecture, Biosynthetic Pathways, and Analytical Protocols

Executive Summary

2-Hydroxynonanoic acid (2-HNA), also known as

-hydroxypelargonic acid, is a medium-chain

-hydroxy fatty acid (2-OH FA). Unlike its non-hydroxylated parent (nonanoic acid), the presence of a hydroxyl group at the

-carbon (C2) confers unique physicochemical properties, including increased acidity and the capacity for intermolecular hydrogen bonding. Biologically, 2-HNA is a critical intermediate in the biosynthesis of hydroxylated sphingolipids, essential for the structural integrity of myelin sheaths and the epidermal permeability barrier. This guide details the chemical properties, synthesis pathways, and validated analytical protocols for 2-HNA.

Part 1: Physicochemical Architecture

Structural Analysis & Stereochemistry

The defining feature of 2-HNA is the substitution of a hydrogen atom at the C2 position with a hydroxyl group. This creates a chiral center, resulting in two enantiomers:

-2-hydroxynonanoic acid and

-2-hydroxynonanoic acid. In mammalian sphingolipids, the

-enantiomer is the predominant biological form, synthesized enzymatically.

Chemical Structure Visualization

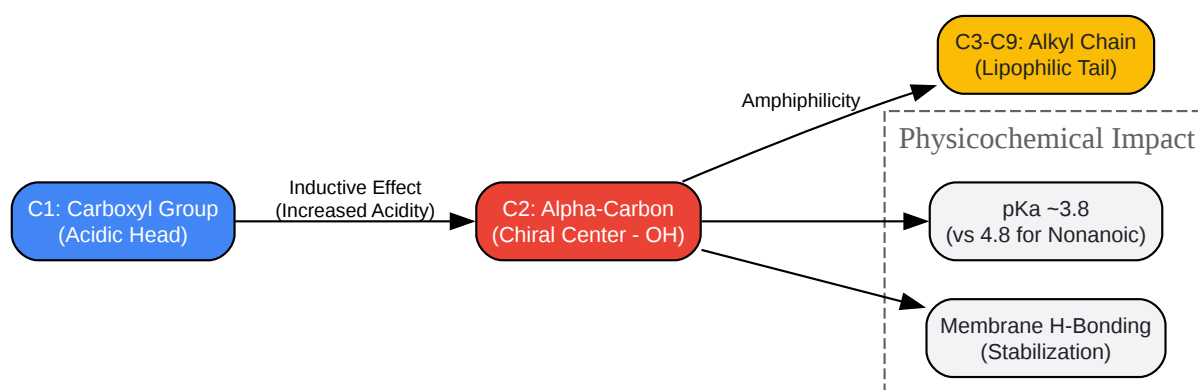

[Click to download full resolution via product page](#)

Figure 1: Structural functionalization of 2-HNA. The electron-withdrawing hydroxyl group at C2 lowers the pKa relative to non-substituted fatty acids.

Key Physicochemical Properties

The

-hydroxyl group significantly alters the solubility profile and acidity compared to nonanoic acid.

Property	Value / Description	Mechanistic Insight
Molecular Formula		Medium-chain fatty acid derivative.[1]
Molecular Weight	174.24 g/mol	Suitable for GC-MS analysis after derivatization.
pKa (Acid)	~3.8 (Predicted)	The -OH group exerts an electron-withdrawing inductive effect (), stabilizing the carboxylate anion more effectively than in unsubstituted fatty acids (pKa ~4.8).
Solubility	Amphiphilic	Soluble in alcohols, chloroform, and ethyl acetate. Poorly soluble in water due to the lipophilic tail, but more soluble than nonanoic acid.
Physical State	Low-melting Solid	Likely melts between 40–50°C (Interpolated from C8 and C10 homologs).
Chirality	and	Biological systems (FA2H enzyme) specifically produce the -enantiomer.

Part 2: Biosynthesis & Chemical Synthesis

Biosynthetic Pathway: Fatty Acid 2-Hydroxylase (FA2H)

In mammalian systems, 2-HNA is not typically formed via

-oxidation but is synthesized directly from nonanoic acid (or its CoA ester) by the enzyme Fatty Acid 2-Hydroxylase (FA2H). This enzyme is critical in the nervous system for producing 2-hydroxy galactolipids (cerebrosides).

Mechanistic Pathway:

- Activation: Nonanoic acid is converted to Nonanoyl-CoA.
- Hydroxylation: FA2H, an NADPH-dependent monooxygenase, introduces a hydroxyl group at the C2 position with high stereospecificity for the *S*-configuration.
- Incorporation: The resulting 2-hydroxynonanoyl-CoA is utilized by ceramide synthase to form hydroxy-ceramides.

Chemical Synthesis: Hell-Volhard-Zelinsky Modification

For laboratory standards (racemic mixtures), the Hell-Volhard-Zelinsky (HVZ) reaction followed by hydrolysis is the standard protocol.

- Bromination: Nonanoic acid + Br_2 / PBr_5
2-Bromononanoic acid.
- Hydrolysis: 2-Bromononanoic acid + NaOH / H_2O
2-Hydroxynonanoic acid.

Part 3: Biological Significance

Membrane Biophysics & Lipid Rafts

2-Hydroxy fatty acids are unique stabilizers of biological membranes.^[2]

- Hydrogen Bonding Network: The C2-hydroxyl group acts as a hydrogen bond donor/acceptor at the membrane interface.^[2] It bridges the amide group of the sphingosine backbone and

the polar headgroups of neighboring lipids.

- Impact: This interaction increases the melting temperature () of the lipid bilayer and promotes the formation of liquid-ordered () phases, also known as lipid rafts. These domains are crucial for signal transduction and protein sorting.

Clinical Relevance[2][3][4][5]

- Skin Barrier: 2-OH ceramides are essential for the epidermal water barrier. Deficiency leads to ichthyosis (dry, scaling skin).
- Neurodegeneration: Mutations in the FA2H gene lead to Leukodystrophy and Spastic Paraplegia, highlighting the role of 2-OH FAs in myelin stability.

Part 4: Analytical Protocol (GC-MS)

Objective: Quantification of 2-HNA in biological samples. Challenge: The hydroxyl and carboxyl groups make the molecule non-volatile and thermally unstable. Double derivatization is required.

Workflow Visualization

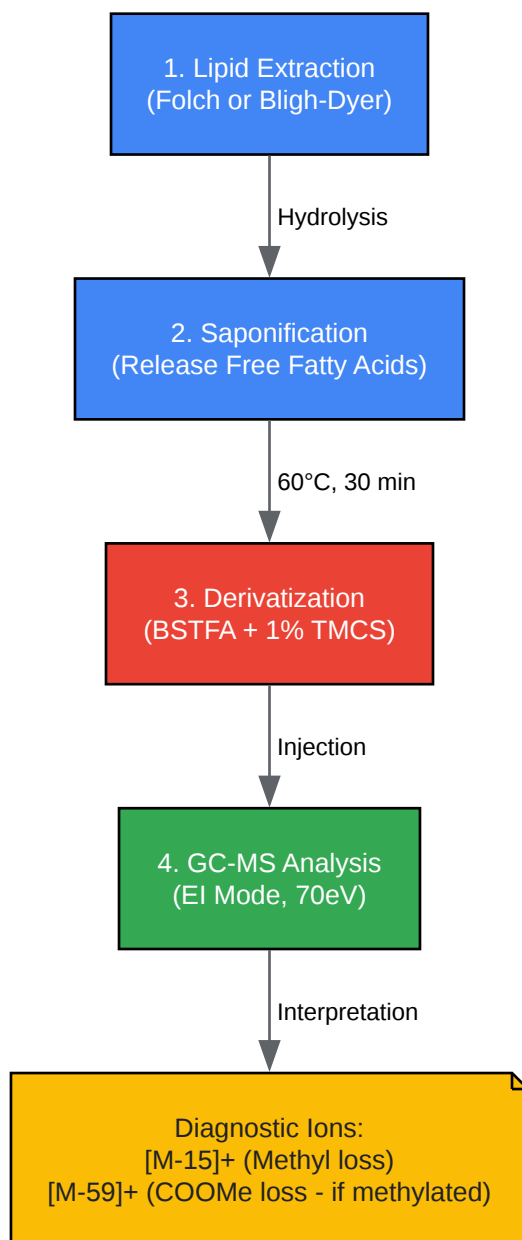

[Click to download full resolution via product page](#)

Figure 2: Validated GC-MS workflow for 2-hydroxy fatty acid analysis.

Detailed Protocol: TMS Derivatization

This protocol converts both the -COOH and -OH groups into Trimethylsilyl (TMS) esters/ethers, rendering the molecule volatile.

Reagents:

- N,O-Bis(trimethylsilyl)trifluoroacetamide (BSTFA)
- Trimethylchlorosilane (TMCS) (Catalyst, 1%)
- Pyridine (Anhydrous solvent)[3]

Step-by-Step Procedure:

- Sample Prep: Dry the lipid extract containing 2-HNA completely under a stream of nitrogen.
Critical: Moisture hydrolyzes TMS derivatives.
- Solubilization: Add 50

L of anhydrous pyridine. Vortex for 10 seconds.
- Derivatization: Add 50

L of BSTFA + 1% TMCS. Cap the vial immediately (Teflon-lined cap).
- Reaction: Incubate at 60°C for 30 minutes.
 - Why: The sterically hindered secondary hydroxyl at C2 requires heat for complete silylation compared to primary alcohols.
- Analysis: Inject 1

L into GC-MS (Splitless mode).

Self-Validating Check:

- Monitor the peak shape.[4] Tailing indicates incomplete derivatization or moisture contamination.
- Look for the M-15 ion (loss of methyl from TMS) and M-90 ion (loss of trimethylsilanol), which are characteristic of TMS-derivatized hydroxy acids.

Alternative: Methyl Ester / TMS Ether

For higher stability, convert the carboxyl group to a methyl ester (using

-Methanol) first, then silylate the hydroxyl group.

- Diagnostic Ion: The mass spectrum will show a prominent peak at [M-59], corresponding to the cleavage of the carbomethoxy group () alpha to the ether oxygen. This is the "fingerprint" for 2-hydroxy fatty acid methyl esters.

References

- Alderson, N. L., et al. (2004). "Physicochemical properties of alpha-hydroxy fatty acids." Journal of Lipid Research.
- Hama, H. (2010). "Fatty acid 2-Hydroxylation in Mammalian Sphingolipid Biology." Biochimica et Biophysica Acta (BBA) - Molecular and Cell Biology of Lipids.
- Jenske, R., &vetter, W. (2007). "Gas chromatography/mass spectrometry analysis of hydroxy fatty acids." Journal of Chromatography A.
- Uchida, Y., et al. (2000). "Hydroxylation of the fatty acyl moiety of sphingolipids." [5][6] Journal of Biological Chemistry.
- PubChem Compound Summary. (2024). "**2-Hydroxynonanoic acid**." [1][7] National Center for Biotechnology Information.

Need Custom Synthesis?

BenchChem offers custom synthesis for rare earth carbides and specific isotopic labeling.

Email: info@benchchem.com or [Request Quote Online](#).

Sources

1. [2-Hydroxynonanoic acid | C9H18O3 | CID 5282897 - PubChem](#) [pubchem.ncbi.nlm.nih.gov]
2. [2'-Hydroxy ceramide in membrane homeostasis and cell signaling - PMC](#) [pmc.ncbi.nlm.nih.gov]
3. [A Gas Chromatography-Mass Spectrometry Method for the Determination of Fatty Acids and Sterols in Yeast and Grape Juice](#) [mdpi.com]

- [4. Simplified derivatization for determining sphingolipid fatty acyl composition by gas chromatography–mass spectrometry - PMC \[pmc.ncbi.nlm.nih.gov\]](#)
- [5. mdpi.com \[mdpi.com\]](#)
- [6. researchgate.net \[researchgate.net\]](#)
- [7. \(R\)-2-hydroxynonanoic acid | C9H18O3 | CID 45266525 - PubChem \[pubchem.ncbi.nlm.nih.gov\]](#)
- To cite this document: BenchChem. [Technical Monograph: 2-Hydroxynonanoic Acid]. BenchChem, [2026]. [Online PDF]. Available at: [\[https://www.benchchem.com/product/b1233570/docs#technical-monograph-2-hydroxynonanoic-acid\]](https://www.benchchem.com/product/b1233570/docs#technical-monograph-2-hydroxynonanoic-acid)

Disclaimer & Data Validity:

The information provided in this document is for Research Use Only (RUO) and is strictly not intended for diagnostic or therapeutic procedures. While BenchChem strives to provide accurate protocols, we make no warranties, express or implied, regarding the fitness of this product for every specific experimental setup.

Technical Support: The protocols provided are for reference purposes. Unsure if this reagent suits your experiment?

Need Industrial/Bulk Grade? [Request Custom Synthesis Quote](#)

BenchChem

Our mission is to be the trusted global source of essential and advanced chemicals, empowering scientists and researchers to drive progress in science and industry.

Contact

Address: 3281 E Guasti Rd
Ontario, CA 91761, United States
Phone: (601) 213-4426
Email: info@benchchem.com

Contact our Ph.D. Support Team for a compatibility check