

A Comparative Guide to the Synthesis of Tertiary Alcohols: Grignard vs. Methyllithium Reagents

Author: BenchChem Technical Support Team. **Date:** April 2026

Compound of Interest

Compound Name: 2-(2-Bromo-5-methylphenyl)propan-2-ol
Cat. No.: B12329135

[Get Quote](#)

For the discerning researcher in organic synthesis and drug development, the choice of a nucleophilic methylating agent for the construction of tertiary alcohols is a critical decision point. The two most prominent contenders for this role, Grignard reagents (specifically methylmagnesium halides) and methyllithium, each present a unique profile of reactivity, selectivity, and practical handling considerations. This guide provides an in-depth, objective comparison to inform your selection process, supported by mechanistic insights and practical experimental data.

Mechanistic Underpinnings: A Tale of Two Metals

The synthesis of tertiary alcohols from ketones or esters hinges on the nucleophilic addition of a methyl group to the carbonyl carbon.^[1] While both Grignard reagents and methyllithium excel at this transformation, the nature of the carbon-metal bond dictates their reactivity.^{[2][3]}

- Grignard Reagents (R-MgX): The carbon-magnesium bond possesses significant ionic character, rendering the methyl group a potent nucleophile.^[4] The reaction with a ketone proceeds through a nucleophilic attack on the carbonyl carbon, forming a magnesium alkoxide intermediate, which is subsequently protonated during aqueous workup to yield the

tertiary alcohol.[4][5] When an ester is the substrate, the reaction proceeds through two successive additions.[1][2][6] The first addition forms a ketone intermediate which is more reactive than the starting ester and rapidly undergoes a second nucleophilic attack by another equivalent of the Grignard reagent.[1][2]

- Methyllithium (CH_3Li): The carbon-lithium bond is even more polarized than the C-Mg bond, making methyllithium a more powerful nucleophile and a stronger base.[2][7] This heightened reactivity can be advantageous in certain scenarios but also introduces challenges in terms of selectivity and handling. The reaction mechanism with ketones and esters is analogous to that of Grignard reagents, involving nucleophilic addition to the carbonyl group.[2]

Visualizing the Mechanisms

To illustrate the subtle yet significant differences in the transition states and intermediates, the following diagrams outline the reaction pathways for both reagents with a generic ketone.

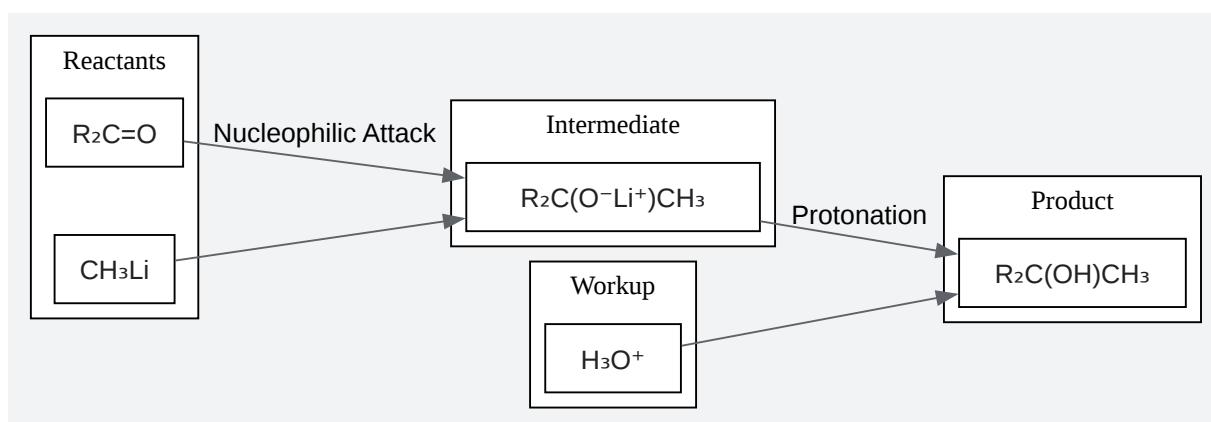
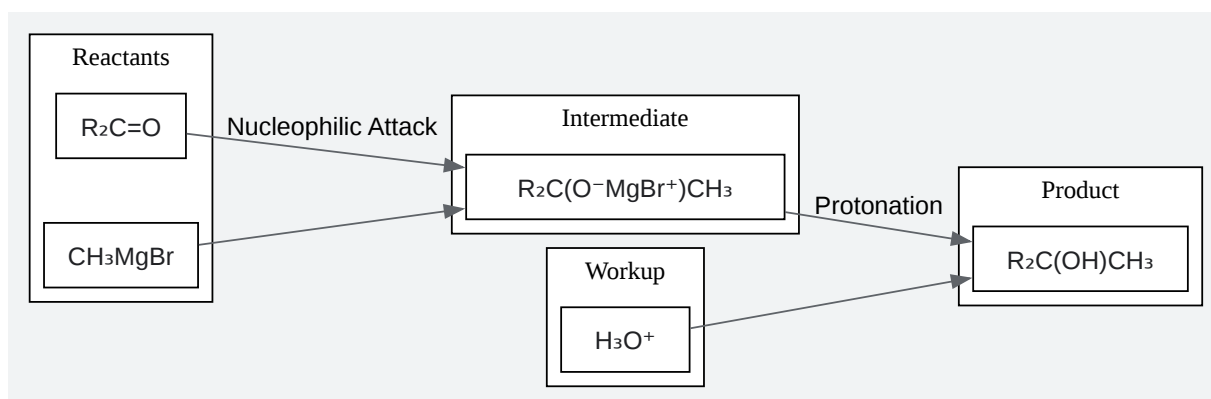

[Click to download full resolution via product page](#)

Caption: Methyllithium reaction with a ketone.

Head-to-Head Comparison: Performance and Practicality

The choice between a Grignard reagent and methyllithium often comes down to a trade-off between reactivity and ease of handling. The following table summarizes the key differences:

Feature	Grignard Reagents (e.g., CH ₃ MgBr)	Methyl lithium (CH ₃ Li)
Reactivity	Highly reactive nucleophiles. [8]	More reactive and more basic than Grignard reagents. [2][7]
Selectivity	Generally good for 1,2-additions to carbonyls. [2] Can act as a base with sterically hindered ketones. [5]	Higher reactivity can lead to reduced selectivity and more side reactions. [7]
Functional Group Tolerance	Intolerant of acidic protons (e.g., -OH, -NH, -SH, terminal alkynes). [3][8]	Even less tolerant of acidic protons due to higher basicity. [3]
Preparation	Can be prepared in situ from magnesium turnings and methyl halide. [9][10]	Typically purchased as a solution; in situ preparation is more hazardous. [11][12]
Solvent	Typically diethyl ether or THF, which are essential for stabilizing the reagent. [3][13]	Often supplied in ethers, but can be used in hydrocarbons. [3][14]
Safety & Handling	Flammable and moisture-sensitive. [8][13] Reactions can be exothermic and require careful control. [13][15]	Pyrophoric (ignites spontaneously in air), highly reactive with water. [11][12] [16] Requires stringent anhydrous and inert atmosphere techniques. [11]
Cost	Generally more cost-effective, especially when prepared in the lab.	Commercially available solutions are typically more expensive.

Experimental Protocols: A Practical Guide

To provide a tangible comparison, the following are detailed protocols for the synthesis of a model tertiary alcohol, 2-phenyl-2-propanol, from acetophenone using both methylmagnesium bromide and methyl lithium.

Protocol 1: Synthesis of 2-phenyl-2-propanol using Methylmagnesium Bromide

Materials:

- Magnesium turnings
- Iodine crystal
- Anhydrous diethyl ether
- Bromomethane (as a solution in diethyl ether) or methyl iodide
- Acetophenone
- Saturated aqueous ammonium chloride solution
- Anhydrous magnesium sulfate

Methodology:

- Grignard Reagent Preparation: In a flame-dried, three-necked flask equipped with a reflux condenser, dropping funnel, and nitrogen inlet, place magnesium turnings and a small crystal of iodine. [17] Add a small portion of a solution of bromomethane in anhydrous diethyl ether. The initiation of the reaction is indicated by the disappearance of the iodine color and gentle refluxing. [18] Once initiated, add the remaining bromomethane solution dropwise to maintain a steady reflux. After the addition is complete, reflux the mixture for an additional 30 minutes to ensure complete reaction.
- Reaction with Ketone: Cool the Grignard solution to 0 °C in an ice bath. Add a solution of acetophenone in anhydrous diethyl ether dropwise from the dropping funnel with vigorous stirring. [17] 3. Workup: After the addition is complete, allow the reaction to warm to room temperature and stir for one hour. Quench the reaction by slowly adding saturated aqueous ammonium chloride solution. [19] 4. Purification: Separate the ether layer, and extract the aqueous layer with diethyl ether. Combine the organic layers, wash with brine, dry over anhydrous magnesium sulfate, filter, and remove the solvent under reduced pressure to yield

the crude tertiary alcohol. [17][20] Further purification can be achieved by recrystallization or distillation.

Protocol 2: Synthesis of 2-phenyl-2-propanol using Methyllithium

Materials:

- Methyllithium (1.6 M solution in diethyl ether)
- Acetophenone
- Anhydrous diethyl ether
- Saturated aqueous ammonium chloride solution
- Anhydrous magnesium sulfate

Methodology:

- **Reaction Setup:** In a flame-dried, three-necked flask equipped with a dropping funnel, nitrogen inlet, and a magnetic stirrer, place a solution of acetophenone in anhydrous diethyl ether. [11]2. **Addition of Methyllithium:** Cool the flask to $-78\text{ }^{\circ}\text{C}$ using a dry ice/acetone bath. Add the methyllithium solution dropwise from the dropping funnel with vigorous stirring. Maintain the temperature below $-70\text{ }^{\circ}\text{C}$ throughout the addition.
- **Workup:** After the addition is complete, allow the reaction to stir at $-78\text{ }^{\circ}\text{C}$ for 30 minutes. Remove the cooling bath and allow the mixture to warm to room temperature. Quench the reaction by the slow, dropwise addition of saturated aqueous ammonium chloride solution.
- **Purification:** Separate the ether layer, and extract the aqueous layer with diethyl ether. Combine the organic layers, wash with brine, dry over anhydrous magnesium sulfate, filter, and remove the solvent under reduced pressure to yield the crude tertiary alcohol. Further purification can be achieved by recrystallization or distillation.

Decision Framework: Choosing the Right Reagent

The selection between a Grignard reagent and methyllithium is not arbitrary but a strategic choice based on the specific requirements of the synthesis. The following workflow provides a logical framework for this decision.

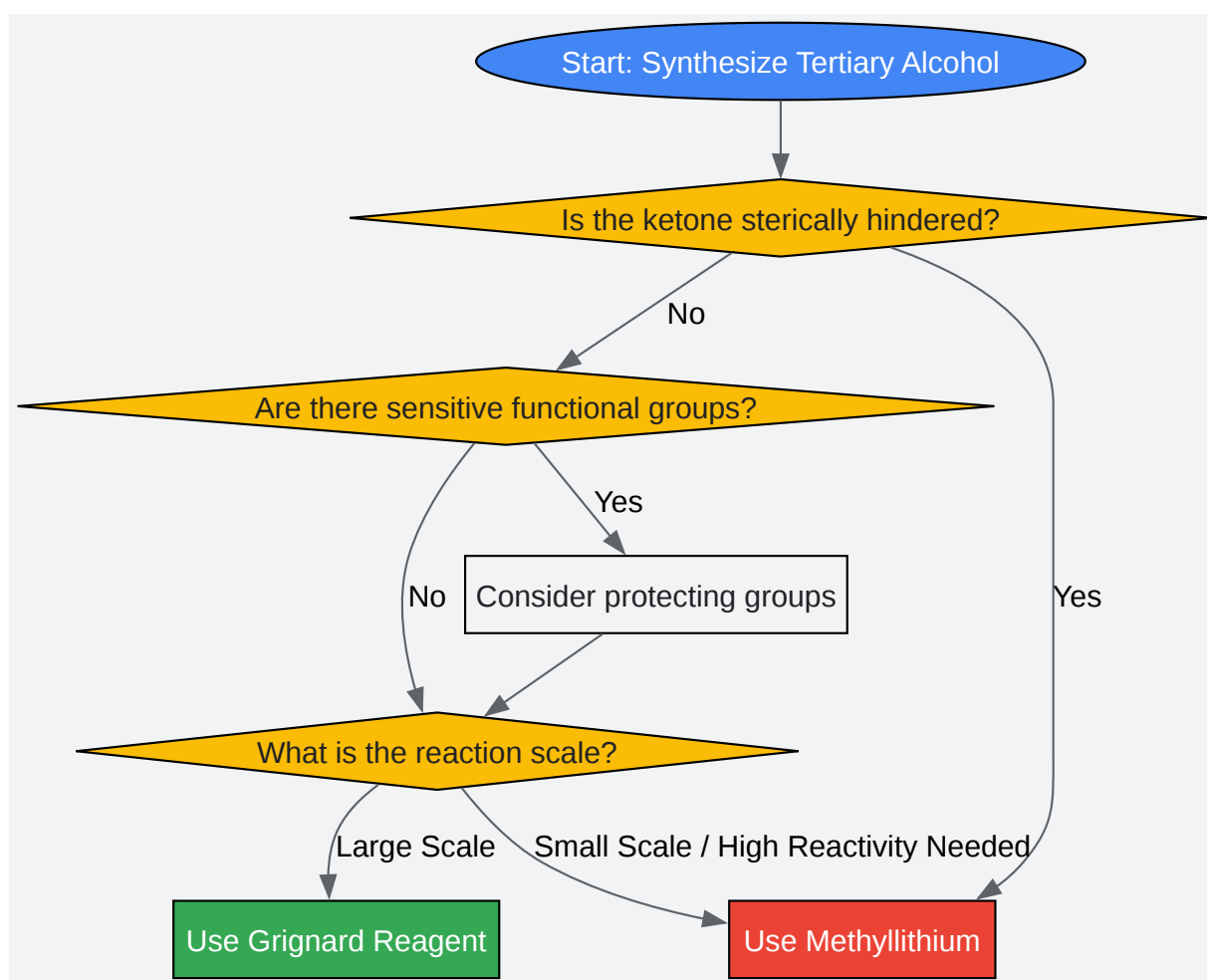

[Click to download full resolution via product page](#)

Caption: Decision workflow for reagent selection.

Conclusion: A Matter of Context and Expertise

Both Grignard reagents and methyllithium are formidable tools for the synthesis of tertiary alcohols. Grignard reagents, particularly for large-scale applications, offer a balance of reactivity, cost-effectiveness, and more manageable safety protocols. [7]Methyllithium, with its heightened reactivity, is the reagent of choice for challenging substrates, such as sterically hindered ketones, where the Grignard reagent might fail or proceed sluggishly. [7]However, its pyrophoric nature demands a higher level of technical expertise and stringent safety precautions. [11][21] Ultimately, the optimal choice is dictated by the specific molecular context, the scale of the reaction, and the laboratory's capabilities. A thorough understanding of the nuances of each reagent, as outlined in this guide, is paramount for successful and safe execution.

References

- Chemistry Steps. (2025, December 3). Grignard (RMgX), Organolithium (RLi), and Gilman (R₂CuLi) Reagents: Summarizing Their Reactions. Retrieved from [\[Link\]](#)
- Master Organic Chemistry. (2015, November 9). Formation of Grignard and Organolithium Reagents From Alkyl Halides. Retrieved from [\[Link\]](#)
- Chemistry LibreTexts. (2023, January 22). Grignard and Organolithium Reagents. Retrieved from [\[Link\]](#)
- Chemistry Steps. (2025, August 5). The Grignard Reaction Mechanism. Retrieved from [\[Link\]](#)
- American Chemical Society. (n.d.). Grignard Reaction. Retrieved from [\[Link\]](#)
- Organic Chemistry Tutor. (n.d.). Synthesis of Alcohols Using the Grignard Reaction. Retrieved from [\[Link\]](#)
- Chemistry LibreTexts. (2020, June 11). 5.2: Practical Considerations, Procedural Changes, Safety Tips. Retrieved from [\[Link\]](#)
- Industrial Chemical Manufacturers. (2024, September 19). Grignard Reaction Reagents: A Toolbox for Chemists. Retrieved from [\[Link\]](#)
- Organic Syntheses. (n.d.). Lithium, methyl-. Retrieved from [\[Link\]](#)

- Organic Chemistry Portal. (n.d.). Grignard Reaction. Retrieved from [\[Link\]](#)
- Stewart, S. M. (2020, June 3). Organolithium vs Grignard Reagents [Video]. YouTube. Retrieved from [\[Link\]](#)
- Master Organic Chemistry. (2016, January 13). Grignard Practice Problems: Synthesis Exercises Involving Grignard Reagents. Retrieved from [\[Link\]](#)
- ResearchGate. (n.d.). The reaction of acyl chlorides with methyllithium. Retrieved from [\[Link\]](#)
- NurdRage. (2018, February 18). Using the Grignard Reaction to Make Tertiary alcohols [Video]. YouTube. Retrieved from [\[Link\]](#)
- Master Organic Chemistry. (2015, December 10). Reactions of Grignard Reagents. Retrieved from [\[Link\]](#)
- University of Wisconsin-Madison. (n.d.). Developing SOPs for Hazardous Chemical Manipulations. Retrieved from [\[Link\]](#)
- Organic Syntheses. (n.d.). 2-. Retrieved from [\[Link\]](#)
- Chemguide. (n.d.). REACTION OF ALDEHYDES AND KETONES WITH GRIGNARD REAGENTS. Retrieved from [\[Link\]](#)
- Der Pharma Chemica. (n.d.). A one-pot two-step synthesis of tertiary alcohols combining the biocatalytic laccase/TEMPO oxidation system with organolithium r. Retrieved from [\[Link\]](#)
- Wikipedia. (n.d.). Methyllithium. Retrieved from [\[Link\]](#)
- Der Pharma Chemica. (n.d.). Synthesis of Tertiary Alcohols via an Ionic Liquid Catalyst. Retrieved from [\[Link\]](#)
- brainly.com. (2023, June 25). [FREE] Reaction of excess methyllithium with ethyl acetate (CH₃CO₂C₂H₅) produces,. Retrieved from [\[Link\]](#)
- University of Calgary. (n.d.). Synthesis and Structure of Alcohols. Retrieved from [\[Link\]](#)

- Chemistry Stack Exchange. (2020, August 29). Why can't Grignard reagents react like Organolithium does (with acids)?. Retrieved from [[Link](#)]
- OperaChem. (2024, May 31). The mechanism of Grignard reaction: finally unravelled. Retrieved from [[Link](#)]
- Organic Chemistry Portal. (n.d.). Alcohol synthesis by 1,2-addition. Retrieved from [[Link](#)]
- Khan Academy. (2012, August 25). Synthesis of alcohols using Grignard reagents II [Video]. YouTube. Retrieved from [[Link](#)]
- Google Patents. (n.d.). EP1682627B1 - Process for preparing methyllithium.
- Chemistry university. (2021, April 27). Organometallic Reagents: Reactions with Carboxylic Acid Derivatives [Video]. YouTube. Retrieved from [[Link](#)]
- Master Organic Chemistry. (2015, December 16). Protecting Groups In Grignard Reactions. Retrieved from [[Link](#)]
- Master Organic Chemistry. (2011, October 14). Grignard Reagents: Their Formation, Reactions, And Reaction Mechanisms. Retrieved from [[Link](#)]

Need Custom Synthesis?

BenchChem offers custom synthesis for rare earth carbides and specific isotopic labeling.

Email: info@benchchem.com or [Request Quote Online](#).

Sources

- [1. masterorganicchemistry.com](https://www.masterorganicchemistry.com) [[masterorganicchemistry.com](https://www.masterorganicchemistry.com)]
- [2. Grignard \(RMgX\), Organolithium \(RLi\), and Gilman \(R₂CuLi\) Reagents: Summarizing Their Reactions - Chemistry Steps](https://www.chemistrysteps.com) [[chemistrysteps.com](https://www.chemistrysteps.com)]
- [3. chem.libretexts.org](https://chem.libretexts.org) [chem.libretexts.org]
- [4. The Grignard Reaction Mechanism - Chemistry Steps](https://www.chemistrysteps.com) [[chemistrysteps.com](https://www.chemistrysteps.com)]
- [5. Grignard Reaction](https://www.organic-chemistry.org) [[organic-chemistry.org](https://www.organic-chemistry.org)]

- [6. masterorganicchemistry.com \[masterorganicchemistry.com\]](https://www.masterorganicchemistry.com)
- [7. youtube.com \[youtube.com\]](https://www.youtube.com)
- [8. Grignard Reaction Reagents: A Toolbox for Chemists - Reachem \[reachemchemicals.com\]](https://www.reachemchemicals.com)
- [9. masterorganicchemistry.com \[masterorganicchemistry.com\]](https://www.masterorganicchemistry.com)
- [10. chemguide.co.uk \[chemguide.co.uk\]](https://www.chemguide.co.uk)
- [11. orgsyn.org \[orgsyn.org\]](https://www.orgsyn.org)
- [12. Methyllithium - Wikipedia \[en.wikipedia.org\]](https://en.wikipedia.org)
- [13. acs.org \[acs.org\]](https://www.acs.org)
- [14. EP1682627B1 - Process for preparing methyllithium - Google Patents \[patents.google.com\]](https://patents.google.com)
- [15. dchas.org \[dchas.org\]](https://www.dchas.org)
- [16. fishersci.com \[fishersci.com\]](https://www.fishersci.com)
- [17. pdf.benchchem.com \[pdf.benchchem.com\]](https://pdf.benchchem.com)
- [18. chem.libretexts.org \[chem.libretexts.org\]](https://chem.libretexts.org)
- [19. m.youtube.com \[m.youtube.com\]](https://m.youtube.com)
- [20. derpharmachemica.com \[derpharmachemica.com\]](https://www.derpharmachemica.com)
- [21. echemi.com \[echemi.com\]](https://www.echemi.com)
- To cite this document: BenchChem. [A Comparative Guide to the Synthesis of Tertiary Alcohols: Grignard vs. Methyllithium Reagents]. BenchChem, [2026]. [Online PDF]. Available at: [<https://www.benchchem.com/product/b12329135/docs#a-comparative-guide-to-the-synthesis-of-tertiary-alcohols-grignard-vs-methyllithium-reagents>]

Disclaimer & Data Validity:

The information provided in this document is for Research Use Only (RUO) and is strictly not intended for diagnostic or therapeutic procedures. While BenchChem strives to provide accurate protocols, we make no warranties, express or implied, regarding the fitness of this product for every specific experimental setup.

Technical Support: The protocols provided are for reference purposes. Unsure if this reagent suits your experiment?

Need Industrial/Bulk Grade? [Request Custom Synthesis Quote](#)

BenchChem

Our mission is to be the trusted global source of essential and advanced chemicals, empowering scientists and researchers to drive progress in science and industry.

Contact

Address: 3281 E Guasti Rd
Ontario, CA 91761, United States
Phone: (601) 213-4426
Email: info@benchchem.com

[Contact our Ph.D. Support Team for a compatibility check](#)