

Application Note: Advanced Radiosynthesis of Aminopyridine-Based PET Tracers

Author: BenchChem Technical Support Team. **Date:** April 2026

Compound of Interest

Compound Name: 4-(1-Aminoethyl)pyridin-2-amine

Cat. No.: B12327400

[Get Quote](#)

Executive Summary & Strategic Rationale

Aminopyridines (APs) are privileged pharmacophores in neuroimaging and oncology, serving as core scaffolds for potassium channel blockers (e.g., 4-aminopyridine for Multiple Sclerosis), iNOS inhibitors, and tau aggregation ligands.[1] However, developing Positron Emission Tomography (PET) tracers from AP precursors presents a distinct "Nucleophile Paradox":

- **Regioselectivity:** The pyridine ring nitrogen is often more nucleophilic than the exocyclic amine, leading to unwanted N-alkylation byproducts during standard labeling.[1]
- **Electronic Deactivation:** The electron-deficient nature of the pyridine ring makes standard nucleophilic aromatic substitution () with difficult, particularly at the meta (3- or 5-) positions.

This guide details two field-proven protocols that circumvent these barriers: Palladium/Copper-mediated

C-methylation and Pyridine

-oxide activated

fluorination.

Chemical Strategy: Overcoming the Aminopyridine Scaffold

The Challenge of Direct Labeling

In standard alkylation conditions (e.g.,

+ Base), the pyridine nitrogen (

) competes with the exocyclic amine. While deprotonation of the amine (

) requires strong bases (e.g., NaH), these conditions often degrade delicate precursors.

Furthermore, direct fluorination of electron-rich aminopyridines is kinetically unfavorable without strong electron-withdrawing groups (EWGs).

The Solutions

- For Carbon-11: Use Stille Cross-Coupling.^{[1][2][3]} By employing an organostannane precursor, we direct the label to a specific carbon atom, bypassing nitrogen nucleophilicity entirely.^[1]
- For Fluorine-18: Use
 - Oxide Activation.^[1] Converting the pyridine precursor to a pyridine-
 - oxide activates the ring for nucleophilic attack, even at the meta position, and allows for subsequent reduction to the desired aminopyridine.

Visual Workflow: Strategic Pathways

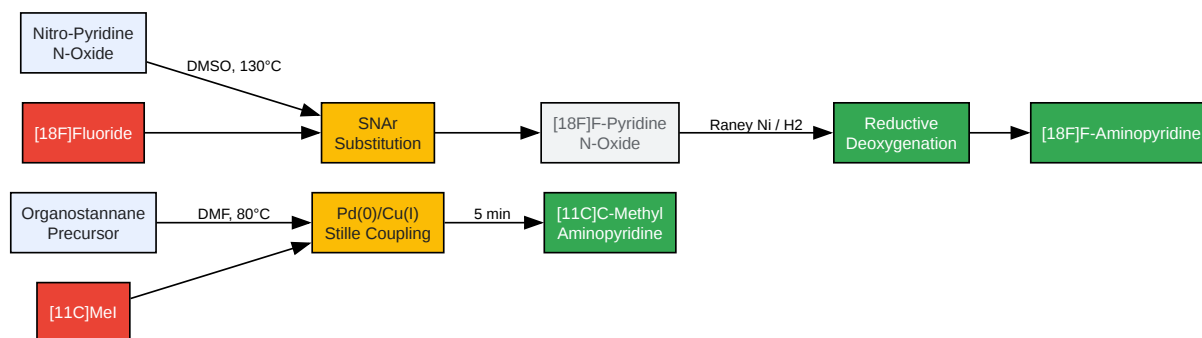

[Click to download full resolution via product page](#)

Caption: Dual pathways for Aminopyridine labeling. Top: C-11 C-methylation via Stille coupling. [1][3] Bottom: F-18 fluorination via N-oxide activation and reduction.

Protocol A: Carbon-11 Labeling via Pd/Cu-Mediated Stille Coupling[3]

Target Application: Synthesis of

-methyl-4-aminopyridine (

) for K⁺ channel imaging. Mechanism: The addition of Copper(I) salts scavenges phosphine ligands and accelerates the transmetalation step, boosting yields for electron-rich heterocycles.

Reagents & Equipment[1][6][7][8]

- Precursor: 3-(tributylstannyl)pyridin-4-amine (High purity >95%).
- Radionuclide:
(produced via gas phase method).[1]
- Catalyst System:

(Tris(dibenzylideneacetone)dipalladium(0)) and

[1]

- Co-Catalyst: CuCl (Copper(I) chloride).[1]
- Solvent: Anhydrous DMF (Dimethylformamide).[1]

Step-by-Step Methodology

- Catalyst Preparation (Glovebox/Inert Atmosphere):
 - In a septum-sealed vial, weigh

(1.5 mg) and

(1.5 mg).[1]
 - Add CuCl (0.5 mg).[1] Note: CuCl is hygroscopic; handle rapidly.[1]
 - Dissolve in 300 μ L of degassed anhydrous DMF.
- Precursor Addition:
 - Add 2.0 mg of the stannyl precursor to the catalyst solution. Vortex for 30 seconds to ensure homogeneity.
- Radiolabeling:
 - Trap

into the reaction vial at room temperature.
 - Once radioactivity peaks, heat the reaction vessel to 80°C for 5 minutes.
 - Critical Insight: Do not exceed 90°C. Higher temperatures promote homocoupling of the stannane and decomposition of the Pd catalyst.
- Quench & Purification:

- Quench with 1.5 mL of HPLC mobile phase (e.g., 10 mM Ammonium Acetate:Acetonitrile).
[1]
- Inject onto a semi-preparative HPLC (Reverse Phase C18).[1]
- Collect the product peak (typically elutes after the hydrolyzed tin byproducts).[1]
- Formulation:
 - Dilute fraction with water, pass through a C18 Sep-Pak, wash with water, and elute with ethanol (1 mL) into saline.

Data Summary: Typical Results

Parameter	Value
Radiochemical Yield (RCY)	40–60% (decay corrected)

| Molar Activity (

) | >100 GBq/μmol | | Radiochemical Purity | >99% | | Synthesis Time | 35 minutes |

Protocol B: Fluorine-18 Labeling via Pyridine - Oxide[7]

Target Application: Synthesis of

-fluoro-4-aminopyridine (

) for MS demyelination imaging. Mechanism: The

-oxide moiety withdraws electron density, activating the 3-position (meta) for nucleophilic attack by

. The

-oxide is subsequently removed to restore the pyridine.

Reagents & Equipment[1][6][7][8][9][10]

- Precursor: 3-bromo-4-nitropyridine [ngcontent-ng-c2977031039="" _ngghost-ng-c1310870263="" class="inline ng-star-inserted">](#)

-oxide. [\[1\]](#)[\[4\]](#)[\[5\]](#)

- Isotope:

(azeotropically dried with

/

). [\[1\]](#)

- Solvent: DMSO (Dimethyl sulfoxide). [\[1\]](#)
- Reducing Agent: Raney Nickel (slurry in ethanol) + Hydrazine or
gas. [\[1\]](#)

Step-by-Step Methodology

- Azeotropic Drying:
 - Trapped
is eluted into the reaction vessel with
/
solution. [\[1\]](#)
 - Dry at 100°C under He flow/vacuum. [\[1\]](#) Add acetonitrile (1 mL) and dry again (repeat 2x) to remove all traces of water. [\[1\]](#) Water severely inhibits nucleophilic fluorination. [\[1\]](#)
- Nucleophilic Substitution (
):
 - Dissolve 3-bromo-4-nitropyridine
-oxide (5 mg) in 0.5 mL DMSO.

- Add to the dried fluoride residue.^{[1][6]}
- Heat at 130°C for 10 minutes.
- Intermediate Check: This yields
-fluoro-4-nitropyridine
-oxide.^{[4][5]}
- One-Pot Reduction (The "Yamada-Curtius" Adaptation):
 - Cool the reactor to 40°C.
 - Add a slurry of Raney Nickel (approx. 50 mg) in Ethanol.^[1]
 - Introduce Hydrogen gas (balloon or controlled flow) or Hydrazine hydrate (50 μL).^[1]
 - Incubate at 60°C for 10 minutes.
 - Mechanism:^{[1][2][7]} This step simultaneously reduces the nitro group to an amine and deoxygenates the
-oxide.
- Filtration & Purification:
 - Filter the mixture through a 0.22 μm PTFE filter to remove Raney Nickel (Radioactive metal waste hazard).^[1]
 - Purify via HPLC (C18 column, 5% EtOH in Phosphate Buffer).
 - Note: Aminopyridines are polar; use a buffer pH ~8 to ensure the free base form if better retention is needed, or low pH for the salt form.^[1]

Data Summary: Typical Results

Parameter	Value
Radiochemical Yield (RCY)	5–15% (decay corrected)

| Molar Activity (

) | 40–80 GBq/μmol | | Purity | >98% | | Synthesis Time | 70–90 minutes |

Quality Control & Troubleshooting

QC Parameters

- Identity: Co-injection with non-radioactive standard (retention time difference < 0.3 min).[1]
- Radionuclidic Purity: Half-life determination (20.4 min for C-11; 109.8 min for F-18).
- Chemical Purity: < 10 μ g/dose of precursor; < 5 ppm residual solvents (DMF/DMSO).[1]

Troubleshooting Guide

Issue	Probable Cause	Corrective Action
Low Yield (Protocol A)	Oxidation of Pd catalyst	Ensure strict inert atmosphere (Glovebox); use fresh .
Homocoupling (Protocol A)	Temperature too high	Reduce reaction temp to 75-80°C; increase CuCl load slightly.
Low Yield (Protocol B)	Wet Fluoride	Dry azeotropically 3x; ensure DMSO is anhydrous.[1]
Incomplete Reduction (Protocol B)	Poisoned Raney Ni	Use fresh Raney Ni; ensure sulfur residues from DMSO don't poison catalyst (dilute with EtOH before adding Ni). [1]

References

- Brugarolas, P., et al. (2018).[1][8] "Development of a PET radioligand for potassium channels to image CNS demyelination." [1][8][9] Scientific Reports. [[Link](#)][1]
- Guehl, N. J., et al. (2021).[1] "Radiochemical Synthesis and Evaluation of 3-[11C]Methyl-4-aminopyridine in Rodents and Nonhuman Primates." ACS Chemical Neuroscience. [[Link](#)][1]
- Matesic, L., et al. (2015).[1] "Synthesis of fluorine-18-labelled 5- and 6-fluoro-2-pyridinamine." Journal of Labelled Compounds and Radiopharmaceuticals. [[Link](#)]
- Doi, H. (2015).[1] "Pd(0)-mediated rapid C-[11C]methylation: revolutionizing the synthesis of short-lived PET probes." Journal of Labelled Compounds and Radiopharmaceuticals. [[Link](#)]
- Basuli, F., et al. (2016).[1] "Rapid synthesis of [18F]fluoropyridines from pyridine N-oxides." Chemical Communications. [[Link](#)]

Need Custom Synthesis?

BenchChem offers custom synthesis for rare earth carbides and specific isotopic labeling.

Email: info@benchchem.com or [Request Quote Online](#).

Sources

- 1. Radiochemical Synthesis and Evaluation in Non-Human Primates of 3-[11C]methoxy-4-aminopyridine: A Novel PET Tracer for Imaging Potassium Channels in the CNS - PubMed [pubmed.ncbi.nlm.nih.gov]
- 2. researchgate.net [researchgate.net]
- 3. Radiochemical Synthesis and Evaluation of 3-[11C]Methyl-4-aminopyridine in Rodents and Nonhuman Primates for Imaging Potassium Channels in the CNS - PMC [pmc.ncbi.nlm.nih.gov]
- 4. researchgate.net [researchgate.net]
- 5. researchgate.net [researchgate.net]
- 6. researchgate.net [researchgate.net]
- 7. pubs.acs.org [pubs.acs.org]

- [8. PET tracer can measure damage from multiple sclerosis - UChicago Medicine \[uchicagomedicine.org\]](#)
- [9. Fluorinated 4-aminopyridines as PET tracers for multiple sclerosis \[morressier.com\]](#)
- To cite this document: BenchChem. [Application Note: Advanced Radiosynthesis of Aminopyridine-Based PET Tracers]. BenchChem, [2026]. [Online PDF]. Available at: [<https://www.benchchem.com/product/b12327400/docs#application-note-advanced-radiosynthesis-of-aminopyridine-based-pet-tracers>]

Disclaimer & Data Validity:

The information provided in this document is for Research Use Only (RUO) and is strictly not intended for diagnostic or therapeutic procedures. While BenchChem strives to provide accurate protocols, we make no warranties, express or implied, regarding the fitness of this product for every specific experimental setup.

Technical Support: The protocols provided are for reference purposes. Unsure if this reagent suits your experiment?

Need Industrial/Bulk Grade? [Request Custom Synthesis Quote](#)

BenchChem

Our mission is to be the trusted global source of essential and advanced chemicals, empowering scientists and researchers to drive progress in science and industry.

Contact

Address: 3281 E Guasti Rd
Ontario, CA 91761, United States
Phone: (601) 213-4426
Email: info@benchchem.com

[Contact our Ph.D. Support Team for a compatibility check](#)

