

A Comparative Guide to the Mass Spectrometry Fragmentation of N-Methylindcarpine

Author: BenchChem Technical Support Team. **Date:** April 2026

Compound of Interest

Compound Name: *N-Methylindcarpine*

Cat. No.: *B12326439*

[Get Quote](#)

For researchers and professionals in drug development and natural product chemistry, the precise structural elucidation of complex molecules is paramount. **N-Methylindcarpine**, a quaternary aporphine alkaloid, presents a unique analytical challenge due to its intricate tetracyclic ring system and multiple functional groups. This guide provides an in-depth analysis of its expected fragmentation patterns under electrospray ionization tandem mass spectrometry (ESI-MS/MS), comparing them with related alkaloid structures to offer a predictive framework for its identification in complex matrices.

Introduction to N-Methylindcarpine and Aporphine Alkaloids

N-Methylindcarpine belongs to the aporphine class of isoquinoline alkaloids, a large family of natural products known for a wide range of pharmacological activities.^{[1][2]} Structurally, it is characterized by a rigid tetracyclic core, a quaternary nitrogen, methoxy groups, a hydroxyl group, and a methylenedioxy bridge. This combination of features makes tandem mass spectrometry an ideal tool for its characterization, as each functional group can influence the fragmentation cascade, producing a diagnostic "fingerprint."

Quaternary aporphine alkaloids, due to their permanent positive charge, typically yield strong molecular ion signals (M^+) in ESI-MS, making them excellent candidates for collision-induced dissociation (CID) experiments.[1][3] Understanding the fragmentation pathways is crucial for differentiating isomers and identifying novel analogues in drug discovery and metabolomics studies.

The Chemical Logic of Fragmentation: Key Pathways

The fragmentation of aporphine alkaloids is not a random process; it is governed by fundamental principles of chemical stability. The fragmentation cascade is dictated by the molecule's structure, with cleavages occurring at the weakest bonds and rearrangements favored when they lead to more stable product ions. For **N-Methylindcarpine**, we can predict several key fragmentation pathways based on extensive studies of related compounds.[2][4][5]

a) Loss of the Quaternary Nitrogen Group:

A hallmark fragmentation for quaternary aporphine alkaloids is the cleavage of the isoquinoline ring system, resulting in the neutral loss of the nitrogen-containing moiety.[3] For **N-Methylindcarpine**, this would involve the loss of N,N-dimethylethylamine or a related fragment. A characteristic ion observed for other quaternary aporphines like magnoflorine is from the neutral loss of C_2H_7N (m/z 45), which signifies the opening of the isoquinoline ring and the elimination of the amino group with its two methyl substituents.[3] This is often a primary and highly diagnostic fragmentation step.

b) Retro-Diels-Alder (RDA) Reaction:

The cyclohexene-like ring within the aporphine core is susceptible to a retro-Diels-Alder (RDA) reaction, a pericyclic process that cleaves the ring into two smaller, stable fragments.[1][6][7] This fragmentation is a powerful tool for localizing substituents on the different rings of the alkaloid skeleton.[6] The way the molecule cleaves can provide significant structural information about the A and D rings of the aporphine nucleus.

c) Cleavage of Peripheral Substituents:

Following the initial major fragmentations, subsequent losses of small neutral molecules from the aromatic substituents are common. These include:

- Loss of a Methyl Radical ($\bullet\text{CH}_3$): From methoxy groups.
- Loss of Methanol (CH_3OH): Occurs when a hydroxyl group is adjacent to a methoxy group. [\[2\]](#)[\[4\]](#)[\[5\]](#)
- Loss of Formaldehyde (CH_2O) followed by Carbon Monoxide (CO): This is characteristic of a methylenedioxy group. [\[2\]](#)[\[4\]](#)[\[5\]](#)
- Loss of Water (H_2O): From the hydroxyl group.

These successive losses help to confirm the presence and arrangement of the substituents on the aromatic rings.

Predicted Fragmentation Pattern of N-Methylindcarpine

Based on the structure of **N-Methylindcarpine** ($\text{C}_{20}\text{H}_{24}\text{NO}_4^+$), with a monoisotopic mass of 342.1705 m/z, we can propose a detailed fragmentation pathway.

Table 1: Predicted Key Fragment Ions for **N-Methylindcarpine**

Precursor Ion (m/z)	Fragment Ion (m/z)	Proposed Neutral Loss	Fragmentation Pathway
342.17	297.11	C ₂ H ₇ N (45 Da)	Loss of the N,N-dimethylaminoethyl moiety
342.17	327.15	•CH ₃ (15 Da)	Loss of a methyl radical from a methoxy group
342.17	311.16	CH ₃ OH (32 Da)	Loss of methanol (from adjacent -OH and -OCH ₃)
297.11	282.09	•CH ₃ (15 Da)	Subsequent loss of a methyl radical
297.11	265.09	CH ₃ OH (32 Da)	Subsequent loss of methanol
265.09	237.09	CO (28 Da)	Subsequent loss of carbon monoxide

This proposed fragmentation is compared with that of Magnoflorine, another well-studied quaternary aporphine alkaloid. Magnoflorine (C₂₀H₂₄NO₄⁺) is an isomer of **N-Methylindcarpine** and shows a characteristic loss of C₂H₇N to form a fragment at m/z 297, which then loses methanol (CH₃OH) to produce an ion at m/z 265.^[3] This comparison provides a strong basis for our predictions for **N-Methylindcarpine**.

Diagram 1: Proposed Fragmentation Pathway of **N-Methylindcarpine**

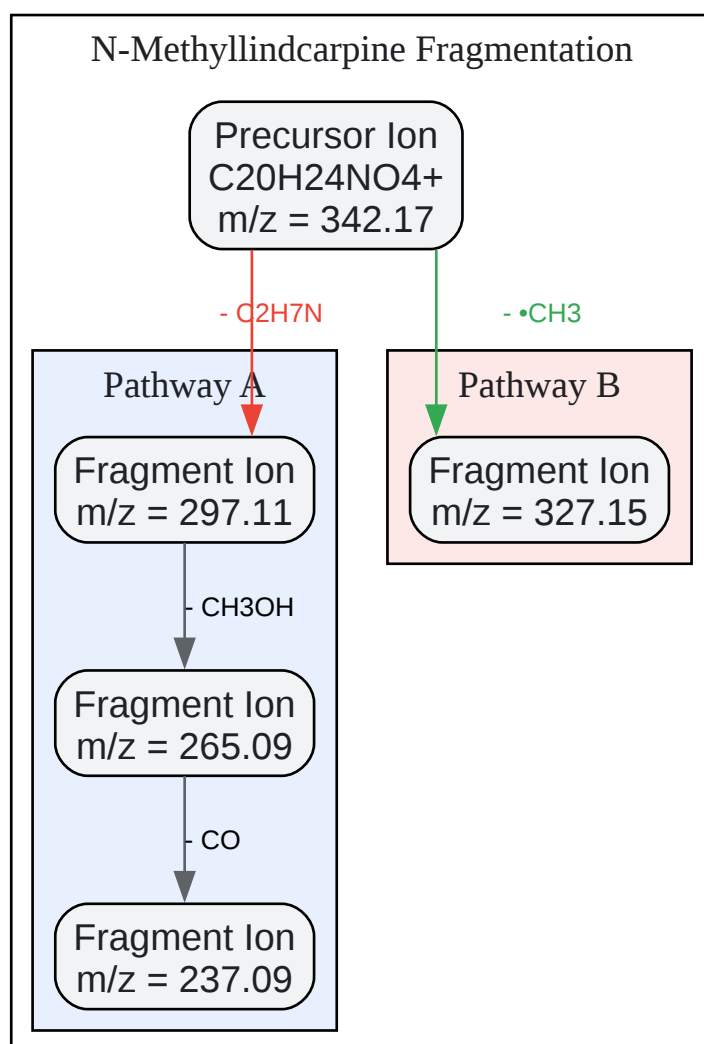

[Click to download full resolution via product page](#)

Caption: Proposed major fragmentation pathways for **N-Methylindcarpine**.

Experimental Protocol for MS/MS Analysis

To validate these predictions, a robust experimental protocol is essential. The following provides a generalized workflow for the analysis of **N-Methylindcarpine** using a Triple Quadrupole or Q-TOF mass spectrometer.

Objective: To acquire high-resolution MS and MS/MS spectra of **N-Methylindcarpine** to confirm its structure and elucidate its fragmentation pathways.

Materials:

- **N-Methylindcarpine** reference standard
- HPLC-grade Methanol
- HPLC-grade Water
- Formic Acid (0.1%)
- Liquid Chromatography-Tandem Mass Spectrometer (LC-MS/MS)

Procedure:

- Sample Preparation:
 - Prepare a stock solution of **N-Methylindcarpine** at 1 mg/mL in methanol.
 - Create a working solution by diluting the stock solution to 1 µg/mL with 50:50 Methanol:Water containing 0.1% formic acid. The acid ensures efficient protonation for positive ion mode ESI.
- Liquid Chromatography (Optional, for complex mixtures):
 - Column: C18 reverse-phase column (e.g., 2.1 x 50 mm, 1.8 µm).
 - Mobile Phase A: Water + 0.1% Formic Acid.
 - Mobile Phase B: Methanol + 0.1% Formic Acid.
 - Gradient: A suitable gradient to separate the analyte from matrix components.
 - Flow Rate: 0.3 mL/min.
 - Injection Volume: 5 µL.
- Mass Spectrometry (Direct Infusion or LC-coupled):
 - Ionization Mode: Electrospray Ionization (ESI), Positive.
 - Capillary Voltage: 3.5 - 4.5 kV.

- Source Temperature: 120-150 °C.
- Desolvation Temperature: 350-450 °C.
- MS1 (Full Scan): Scan from m/z 100-500 to identify the precursor ion ([M]⁺) at m/z 342.17.
- MS2 (Product Ion Scan):
 - Select the precursor ion m/z 342.17 for fragmentation.
 - Apply a range of collision energies (e.g., 10, 20, 30, 40 eV) to observe the full spectrum of fragment ions. This energy ramping is critical to capture both low-energy (e.g., loss of CH₃OH) and high-energy (e.g., ring cleavage) fragmentations.

Diagram 2: Experimental Workflow for MS/MS Analysis

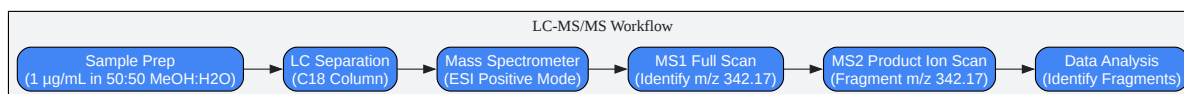

[Click to download full resolution via product page](#)

Caption: Standard workflow for the analysis of **N-Methylindcarpine**.

Conclusion and Broader Implications

The systematic study of **N-Methylindcarpine**'s fragmentation patterns provides a powerful analytical blueprint for its unambiguous identification. By leveraging knowledge from related aporphine alkaloids and applying fundamental mass spectrometry principles, researchers can confidently identify this and similar compounds in complex natural extracts or biological samples. The comparison with known alkaloids like magnoflorine highlights the diagnostic power of key fragmentations, such as the loss of the quaternary amine moiety and subsequent neutral losses from peripheral groups. This guide serves as a practical resource, combining theoretical predictions with a robust experimental protocol to aid scientists in accelerating their research and development efforts in natural product chemistry.

References

- Cho, E., et al. (2018). General Fragmentations of Alkaloids in Electrospray Ionization Tandem Mass Spectrometry. Journal of the Korean Society for Applied Biological Chemistry. Available at: [\[Link\]](#)
- Stévigny, C., et al. (2004). Key fragmentation patterns of aporphine alkaloids by electrospray ionization with multistage mass spectrometry. Rapid Communications in Mass Spectrometry, 18(5), 523-8. Available at: [\[Link\]](#)
- Zhang, M., et al. (2022). A Systematic Method for the Identification of Aporphine Alkaloid Constituents in *Sabia schumanniana* Diels Using UHPLC-Q-Exactive Orbitrap/Mass Spectrometry. Molecules, 27(22), 7709. Available at: [\[Link\]](#)
- PubMed. (2004). Key fragmentation patterns of aporphine alkaloids by electrospray ionization with multistage mass spectrometry. Rapid Communications in Mass Spectrometry. Available at: [\[Link\]](#)
- Scite.ai. (2004). Key fragmentation patterns of aporphine alkaloids by electrospray ionization with multistage mass spectrometry. Rapid Communications in Mass Spectrometry. Available at: [\[Link\]](#)
- Chemistry LibreTexts. (2023). Mass Spectrometry. Available at: [\[Link\]](#)
- ResearchGate. (n.d.). The MS/MS spectrum of alkaloid 1 (A) and the two proposed fragmentation... Available at: [\[Link\]](#)
- Master Organic Chemistry. (2018). The Retro Diels-Alder Reaction. Available at: [\[Link\]](#)

Need Custom Synthesis?

BenchChem offers custom synthesis for rare earth carbides and specific isotopic labeling.

Email: info@benchchem.com or [Request Quote Online](#).

Sources

- [1. scispace.com \[scispace.com\]](#)
- [2. researchgate.net \[researchgate.net\]](#)
- [3. mdpi.com \[mdpi.com\]](#)
- [4. Key fragmentation patterns of aporphine alkaloids by electrospray ionization with multistage mass spectrometry - PubMed \[pubmed.ncbi.nlm.nih.gov\]](#)
- [5. scite.ai \[scite.ai\]](#)
- [6. researchgate.net \[researchgate.net\]](#)
- [7. masterorganicchemistry.com \[masterorganicchemistry.com\]](#)
- To cite this document: BenchChem. [A Comparative Guide to the Mass Spectrometry Fragmentation of N-Methylindcarpine]. BenchChem, [2026]. [Online PDF]. Available at: [<https://www.benchchem.com/product/b12326439/docs#a-comparative-guide-to-the-mass-spectrometry-fragmentation-of-n-methylindcarpine>]

Disclaimer & Data Validity:

The information provided in this document is for Research Use Only (RUO) and is strictly not intended for diagnostic or therapeutic procedures. While BenchChem strives to provide accurate protocols, we make no warranties, express or implied, regarding the fitness of this product for every specific experimental setup.

Technical Support: The protocols provided are for reference purposes. Unsure if this reagent suits your experiment?

Need Industrial/Bulk Grade? [Request Custom Synthesis Quote](#)

BenchChem

Our mission is to be the trusted global source of essential and advanced chemicals, empowering scientists and researchers to drive progress in science and industry.

Contact

Address: 3281 E Guasti Rd

Ontario, CA 91761, United States

Phone: (601) 213-4426

Email: info@benchchem.com

Contact our Ph.D. Support Team for a compatibility check