

Validating the Neuroprotective Mechanism of Scutellarin: A Comparative Guide

Author: BenchChem Technical Support Team. **Date:** April 2026

Compound of Interest

Compound Name: Scutebarbatine X

Cat. No.: B12325117

[Get Quote](#)

For Researchers, Scientists, and Drug Development Professionals

This guide provides an objective comparison of the neuroprotective mechanisms of Scutellarin against two alternative therapeutic agents, Edaravone and Nimodipine. The information presented is supported by experimental data from preclinical studies to aid in the evaluation and validation of Scutellarin's potential as a neuroprotective agent.

Overview of Neuroprotective Mechanisms

Scutellarin, a flavonoid derived from the herb *Erigeron breviscapus*, exhibits robust neuroprotective properties through multiple mechanisms. Its primary modes of action include potent anti-inflammatory and antioxidant effects, as well as the modulation of key signaling pathways involved in cell survival and apoptosis.^{[1][2][3]} This guide compares these mechanisms to those of Edaravone, a free radical scavenger, and Nimodipine, a calcium channel blocker, both of which are used in clinical settings for neuroprotection.

Scutellarin: A multi-target agent with anti-inflammatory, antioxidant, and anti-apoptotic properties.^{[1][2][3]} Edaravone: Primarily a free radical scavenger that mitigates oxidative stress.^{[4][5][6]} Nimodipine: A calcium channel antagonist that prevents calcium overload in neurons, particularly in the context of subarachnoid hemorrhage.^{[7][8][9]}

Comparative Analysis of Neuroprotective Efficacy

Experimental data from in vivo and in vitro models of cerebral ischemia demonstrate the neuroprotective efficacy of Scutellarin. The following tables summarize key quantitative data from comparative and individual studies.

Table 1: In Vivo Neuroprotective Effects in Middle Cerebral Artery Occlusion (MCAO) Models

Compound	Dosage	Infarct Volume Reduction (%)	Neurological Deficit Improvement	Reference
Scutellarin	100 mg/kg	Significant reduction	Significant improvement	[10][11][12]
Edaravone	3 mg/kg	Effective reduction	Effective improvement	[13][14]
Nimodipine	Not directly compared	Varies across studies	Beneficial in some models	[15][16]

Note: Direct comparative quantitative data for Scutellarin vs. Nimodipine in the same MCAO study was not available in the reviewed literature. The efficacy of Nimodipine in focal cerebral ischemia models has shown variable results.[15][16]

Table 2: In Vitro Neuroprotective Effects in Oxygen-Glucose Deprivation (OGD) Models

Compound	Concentration	Cell Viability Increase (%)	Apoptosis Reduction (%)	Reference
Scutellarin	10-50 μ M	Significantly improved	Significantly reduced	[17][18]
Edaravone	10-100 μ M	Dose-dependent increase	Significant inhibition	[19][20]
Nimodipine	10 μ M	Significantly attenuated injury	Protective effects observed	[21][22][23]

Signaling Pathways and Molecular Mechanisms

The neuroprotective effects of Scutellarin and its alternatives are mediated by distinct and overlapping signaling pathways.

Scutellarin's Multi-Target Signaling Cascades

Scutellarin exerts its neuroprotective effects by modulating several key signaling pathways. It is known to activate the PI3K/AKT pathway, a crucial signaling cascade for promoting cell survival and inhibiting apoptosis.[1][24] Furthermore, Scutellarin inhibits inflammatory responses by suppressing the activation of microglia and downregulating the NF- κ B, JNK, and p38 MAPK signaling pathways.[2][3] Its antioxidant properties are, in part, mediated through the activation of the Nrf2 pathway.[1]

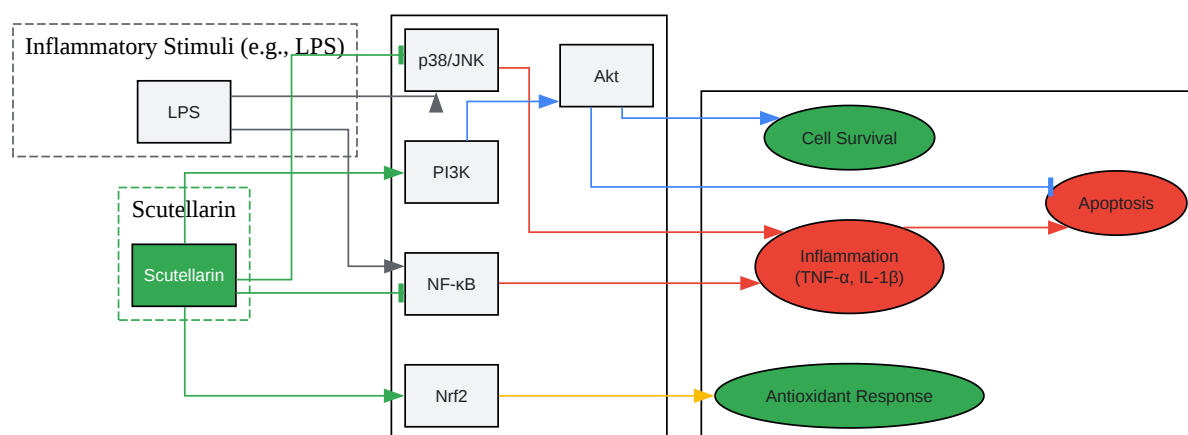

[Click to download full resolution via product page](#)

Scutellarin's neuroprotective signaling pathways.

Edaravone's Free Radical Scavenging Mechanism

Edaravone's primary mechanism is the direct scavenging of reactive oxygen species (ROS) and reactive nitrogen species (RNS), thereby reducing oxidative stress-induced neuronal

damage.[4][5][6] It can also modulate the Keap1/Nrf2 pathway, leading to the expression of antioxidant enzymes.

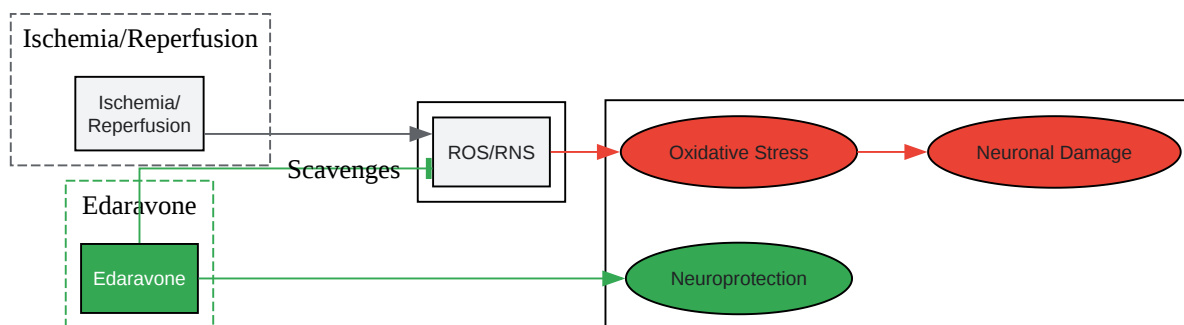

[Click to download full resolution via product page](#)

Edaravone's free radical scavenging action.

Nimodipine's Calcium Channel Blockade

Nimodipine, a dihydropyridine calcium channel blocker, exerts its neuroprotective effects by inhibiting the influx of calcium into neurons.[7][8] This is particularly critical during ischemic events where excessive calcium entry triggers excitotoxicity and subsequent neuronal death.

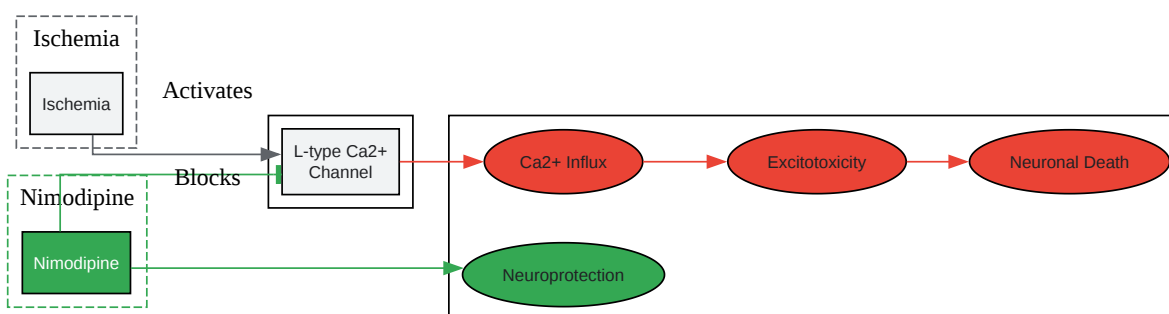

[Click to download full resolution via product page](#)

Nimodipine's calcium channel blocking mechanism.

Experimental Protocols

Detailed methodologies for key experiments are crucial for the validation and replication of findings.

In Vivo Middle Cerebral Artery Occlusion (MCAO) Model

This model is widely used to mimic focal cerebral ischemia.

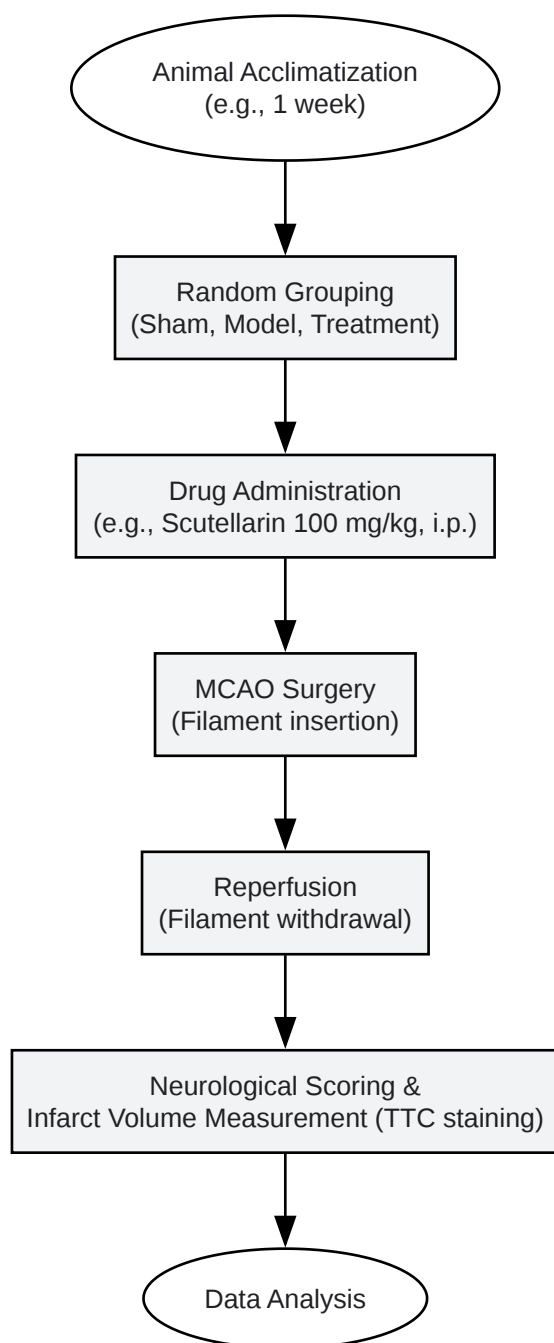

[Click to download full resolution via product page](#)

Workflow for the MCAO in vivo model.

Protocol:

- Animal Model: Adult male Sprague-Dawley or C57BL/6J mice are commonly used.[10][13]

- Anesthesia: Animals are anesthetized, typically with an intraperitoneal injection of a suitable anesthetic.
- MCAO Procedure: The right middle cerebral artery is occluded by inserting a nylon monofilament into the internal carotid artery. Occlusion is typically maintained for 1-2 hours. [\[10\]](#)[\[13\]](#)
- Reperfusion: The filament is withdrawn to allow for blood reperfusion.
- Drug Administration: Scutellarin (e.g., 100 mg/kg), Edaravone (e.g., 3 mg/kg), or Nimodipine is administered, often intraperitoneally, at specific time points before or after the MCAO procedure. [\[10\]](#)[\[11\]](#)[\[13\]](#)[\[14\]](#)
- Assessment: Neurological deficits are scored at various time points post-reperfusion. After a set period (e.g., 24-72 hours), brains are harvested, sectioned, and stained with 2,3,5-triphenyltetrazolium chloride (TTC) to measure the infarct volume. [\[12\]](#)

In Vitro Oxygen-Glucose Deprivation (OGD) Model

This model simulates ischemic conditions in cultured neuronal cells.

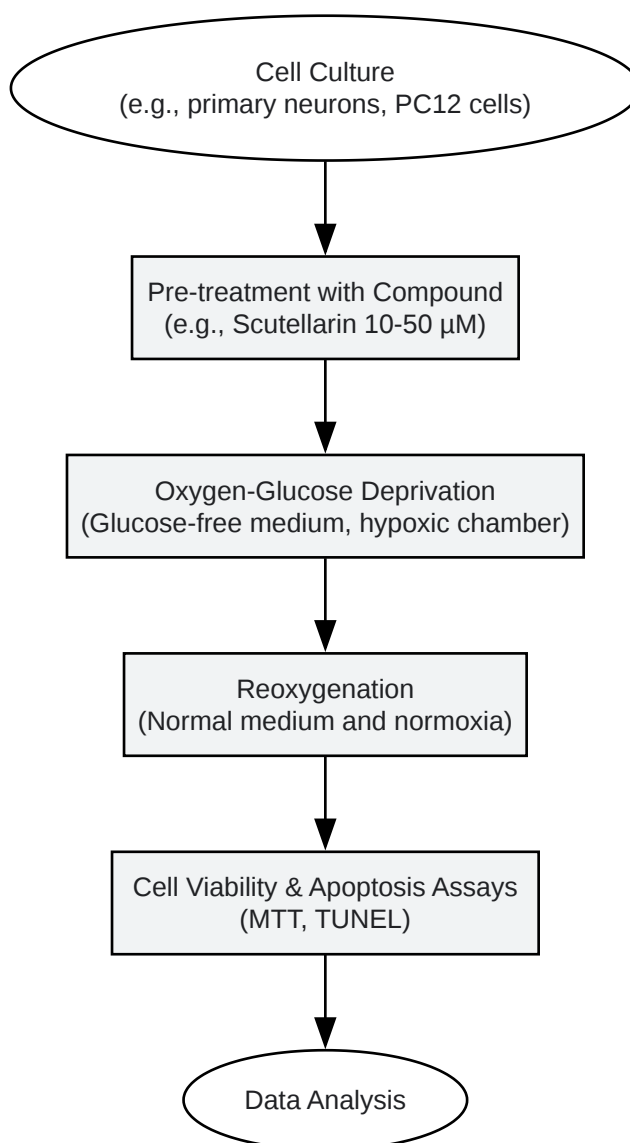

[Click to download full resolution via product page](#)

Workflow for the OGD in vitro model.

Protocol:

- Cell Culture: Primary cortical neurons or cell lines like PC12 are cultured to a suitable confluency.
- OGD Induction: The culture medium is replaced with glucose-free medium, and the cells are placed in a hypoxic chamber (e.g., 95% N₂, 5% CO₂) for a defined period (e.g., 2-4 hours). [\[17\]](#)[\[25\]](#)[\[26\]](#)

- Reoxygenation: The glucose-free medium is replaced with normal culture medium, and the cells are returned to a normoxic incubator.
- Drug Treatment: Cells are typically pre-treated with Scutellarin (e.g., 10-50 μM), Edaravone (e.g., 10-100 μM), or Nimodipine (e.g., 10 μM) for a specific duration before OGD induction. [\[17\]](#)[\[19\]](#)[\[23\]](#)
- Assessment: Cell viability is measured using assays like the MTT or LDH assay. Apoptosis is quantified using methods such as TUNEL staining or by measuring caspase-3 activity.[\[17\]](#)
[\[20\]](#)

Conclusion

Scutellarin demonstrates significant neuroprotective potential through a multi-faceted mechanism that includes anti-inflammatory, antioxidant, and anti-apoptotic actions. In direct comparison with Edaravone, Scutellarin shows comparable or, in some aspects of inflammation modulation, potentially superior efficacy. While a direct quantitative comparison with Nimodipine is lacking in the current literature, Scutellarin's broader mechanistic profile suggests it may offer advantages in neurodegenerative conditions where inflammation and oxidative stress are key pathological drivers, beyond the more specific calcium channel blockade of Nimodipine.

Further head-to-head comparative studies, particularly with Nimodipine, are warranted to fully elucidate the relative therapeutic potential of Scutellarin. The detailed experimental protocols and pathway analyses provided in this guide offer a framework for such validation studies.

Need Custom Synthesis?

BenchChem offers custom synthesis for rare earth carbides and specific isotopic labeling.

Email: info@benchchem.com or [Request Quote Online](#).

References

- [1. Current advances on the therapeutic potential of scutellarin: an updated review - PMC \[pmc.ncbi.nlm.nih.gov\]](#)

- 2. Neuroprotection of Scutellarin is mediated by inhibition of microglial inflammatory activation - PubMed [pubmed.ncbi.nlm.nih.gov]
- 3. researchgate.net [researchgate.net]
- 4. tandfonline.com [tandfonline.com]
- 5. Edaravone's free radical scavenging mechanisms of neuroprotection against cerebral ischemia: review of the literature - PubMed [pubmed.ncbi.nlm.nih.gov]
- 6. scilit.com [scilit.com]
- 7. Nimodipine - StatPearls - NCBI Bookshelf [ncbi.nlm.nih.gov]
- 8. Nimodipine Protects Vascular and Cognitive Function in an Animal Model of Cerebral Small Vessel Disease - PMC [pmc.ncbi.nlm.nih.gov]
- 9. Beyond nimodipine: advanced neuroprotection strategies for aneurysmal subarachnoid hemorrhage vasospasm and delayed cerebral ischemia - PubMed [pubmed.ncbi.nlm.nih.gov]
- 10. Synthesis and Protective Effect of Scutellarein on Focal Cerebral Ischemia/Reperfusion in Rats - PMC [pmc.ncbi.nlm.nih.gov]
- 11. Scutellarin Alleviates Neuronal Apoptosis in Ischemic Stroke via Activation of the PI3K/AKT Signaling Pathway - PMC [pmc.ncbi.nlm.nih.gov]
- 12. researchgate.net [researchgate.net]
- 13. Frontiers | Metabolomic Profiling of Brain Protective Effect of Edaravone on Cerebral Ischemia-Reperfusion Injury in Mice [frontiersin.org]
- 14. Neuroprotection of Oral Edaravone on Middle Cerebral Artery Occlusion in Rats - PubMed [pubmed.ncbi.nlm.nih.gov]
- 15. ahajournals.org [ahajournals.org]
- 16. researchgate.net [researchgate.net]
- 17. Scutellarin protects oxygen/glucose-deprived astrocytes and reduces focal cerebral ischemic injury - PMC [pmc.ncbi.nlm.nih.gov]
- 18. new-discovery.org.cn [new-discovery.org.cn]
- 19. Differential Protective Effects of Edaravone in Cerebellar and Hippocampal Ischemic Injury Models - PMC [pmc.ncbi.nlm.nih.gov]
- 20. Edaravone protects against oxygen-glucose-serum deprivation/restoration-induced apoptosis in spinal cord astrocytes by inhibiting integrated stress response - PMC [pmc.ncbi.nlm.nih.gov]

- [21. researchgate.net \[researchgate.net\]](#)
- [22. Nimodipine Protects PC12 Cells against Oxygen-Glucose Deprivation - Iranian Journal of Pharmacology and Therapeutics \[ijpt.iums.ac.ir\]](#)
- [23. Neuroprotective effects of nimodipine and nifedipine in the NGF-differentiated PC12 cells exposed to oxygen-glucose deprivation or trophic withdrawal - PubMed \[pubmed.ncbi.nlm.nih.gov\]](#)
- [24. Scutellarin alleviates microglia-mediated neuroinflammation and apoptosis after ischemic stroke through the PI3K/AKT/GSK3 \$\beta\$ signaling pathway - PMC \[pmc.ncbi.nlm.nih.gov\]](#)
- [25. Oxygen glucose deprivation/re-oxygenation-induced neuronal cell death is associated with Lnc-D63785 m6A methylation and miR-422a accumulation - PMC \[pmc.ncbi.nlm.nih.gov\]](#)
- [26. Kaempferol Ameliorates Oxygen-Glucose Deprivation/Reoxygenation-Induced Neuronal Ferroptosis by Activating Nrf2/SLC7A11/GPX4 Axis - PMC \[pmc.ncbi.nlm.nih.gov\]](#)
- [To cite this document: BenchChem. \[Validating the Neuroprotective Mechanism of Scutellarin: A Comparative Guide\]. BenchChem, \[2026\]. \[Online PDF\]. Available at: \[https://www.benchchem.com/product/b12325117/docs#validating-the-neuroprotective-mechanism-of-scutellarin-a-comparative-guide\]](#)

Disclaimer & Data Validity:

The information provided in this document is for Research Use Only (RUO) and is strictly not intended for diagnostic or therapeutic procedures. While BenchChem strives to provide accurate protocols, we make no warranties, express or implied, regarding the fitness of this product for every specific experimental setup.

Technical Support: The protocols provided are for reference purposes. Unsure if this reagent suits your experiment?

Need Industrial/Bulk Grade? [Request Custom Synthesis Quote](#)

BenchChem

Our mission is to be the trusted global source of essential and advanced chemicals, empowering scientists and researchers to drive progress in science and industry.

Contact

Address: 3281 E Guasti Rd

Ontario, CA 91761, United States

Phone: (601) 213-4426

Email: info@benchchem.com

[Contact our Ph.D. Support Team for a compatibility check](#)