

# Identifying and minimizing off-target effects of Renifolin F.

**Author:** BenchChem Technical Support Team. **Date:** April 2026

## Compound of Interest

Compound Name: *Renifolin*  
Cat. No.: *B12323878*

[Get Quote](#)

## Technical Support Center: Renifolin F

This technical support center provides researchers, scientists, and drug development professionals with comprehensive guidance on the use of **Renifolin F**, focusing on the identification and minimization of potential off-target effects.

## Frequently Asked Questions (FAQs)

Q1: What is **Renifolin F** and what is its known on-target activity?

A1: **Renifolin F** is a prenylated chalcone isolated from the plant *Shuteria involucrata*.<sup>[1]</sup> Its primary known on-target activity is the attenuation of airway inflammation and hyper-reactivity in allergic asthma models.<sup>[1]</sup> It achieves this by inhibiting the function of type 2 innate lymphoid cells (ILC2s), leading to a reduction in the production of several key inflammatory cytokines.<sup>[2]</sup>

Q2: What is the specific molecular target of **Renifolin F**?

A2: The precise molecular target of **Renifolin F** has not yet been definitively identified. Current research indicates that it modulates the ILC2 signaling pathway, reducing the levels of upstream cytokines like IL-25, IL-33, and TSLP, and downstream cytokines such as IL-4, IL-5,

IL-9, and IL-13.[2] The direct protein(s) that **Renifolin F** binds to initiate these effects is a subject for further investigation.

Q3: What are off-target effects and why are they a concern for small molecules like **Renifolin F**?

A3: Off-target effects are unintended interactions of a drug or compound with proteins or other biomolecules that are not the intended therapeutic target.[3] These interactions can lead to unforeseen biological consequences, including toxicity, reduced efficacy, and confounding experimental results.[4] For a novel compound like **Renifolin F**, characterizing potential off-target effects is a critical step in preclinical development to ensure data integrity and predict potential clinical side effects.[3]

Q4: Are chalcones as a class of compounds known for off-target effects?

A4: Chalcones are a class of naturally occurring compounds known to exhibit a wide range of biological activities, which can sometimes be attributed to their interaction with multiple molecular targets.[5] This promiscuity can be beneficial in some contexts but also increases the likelihood of off-target effects.[5] Therefore, comprehensive profiling of any new chalcone, including **Renifolin F**, is essential.

Q5: What are the general strategies to identify potential off-target effects of **Renifolin F**?

A5: A multi-pronged approach is recommended. This can begin with computational methods to predict potential off-target interactions based on the chemical structure of **Renifolin F**. [3][6] Experimental approaches include broad-panel screening assays, such as kinase profiling, to test for activity against a large number of related proteins. [7][8][9] Unbiased, proteome-wide methods like cellular thermal shift assay (CETSA) can identify direct binding partners within the cell. [10][11]

## Troubleshooting Guides

This section addresses specific issues that may arise during experiments with **Renifolin F**.

Issue 1: I am observing a significant level of cytotoxicity in my cell-based assays with **Renifolin F**, which is unexpected based on the published in vivo data. What could be the cause?

- Possible Cause 1: High Compound Concentration. The concentrations of **Renifolin F** used in your in vitro experiments may be significantly higher than those achieved in vivo, leading to off-target toxicity.
  - Troubleshooting Step: Perform a dose-response curve to determine the EC50 for the on-target effect (e.g., inhibition of cytokine production) and the CC50 for cytotoxicity. Use the lowest effective concentration for your experiments.
- Possible Cause 2: Off-Target Engagement. **Renifolin F** may be interacting with essential cellular proteins in your specific cell line that are not present or as critical in the cell types involved in the in vivo asthma model.
  - Troubleshooting Step: Consider performing a counter-screen with a cell line known to be insensitive to the on-target pathway. If cytotoxicity persists, it is likely due to an off-target effect. Further investigation using the protocols outlined below is recommended.

Issue 2: I am not observing the expected reduction in IL-5 and IL-13 production in my ILC2 cultures after treatment with **Renifolin F**. What should I check?

- Possible Cause 1: Suboptimal Cell Culture Conditions. The activation state and health of your primary ILC2 cultures are critical for observing the effects of **Renifolin F**.
  - Troubleshooting Step: Ensure your ILC2s are properly activated with the appropriate cytokines (e.g., IL-2, IL-7, IL-33) and that cell viability is high prior to and during the experiment.
- Possible Cause 2: Compound Stability and Potency. The batch of **Renifolin F** you are using may have degraded or be of insufficient purity.
  - Troubleshooting Step: Verify the identity and purity of your **Renifolin F** stock by analytical methods such as LC-MS and NMR. If possible, obtain a fresh, validated batch of the compound.
- Possible Cause 3: Experimental Setup. The timing of **Renifolin F** treatment relative to ILC2 activation may be suboptimal.

- Troubleshooting Step: Titrate the timing and duration of **Renifolin F** treatment to determine the optimal window for inhibiting cytokine production.

## Data Presentation

The following table summarizes the known quantitative effects of **Renifolin F** on cytokine levels in an ovalbumin-induced asthma mouse model.[\[2\]](#)

Cytokine	Treatment Group	Concentration (pg/mL)	% Reduction vs. OVA Control
Upstream Cytokines			
IL-25	Control	15.2 ± 2.1	-
OVA Model	45.8 ± 3.5	-	
Renifolin F (1.5 mg/kg)	30.1 ± 2.9	34.3%	
Renifolin F (3.0 mg/kg)	20.5 ± 2.4	55.2%	
IL-33	Control	20.1 ± 2.8	-
OVA Model	62.4 ± 4.1	-	
Renifolin F (1.5 mg/kg)	45.3 ± 3.7	27.4%	
Renifolin F (3.0 mg/kg)	31.8 ± 3.2	49.0%	
TSLP	Control	18.9 ± 2.5	-
OVA Model	55.7 ± 4.3	-	
Renifolin F (1.5 mg/kg)	38.6 ± 3.1	30.7%	
Renifolin F (3.0 mg/kg)	26.4 ± 2.9	52.6%	
Downstream Cytokines			
IL-4	Control	22.5 ± 2.6	-
OVA Model	78.3 ± 5.1	-	
Renifolin F (1.5 mg/kg)	55.1 ± 4.2	29.6%	

Renifolin F (3.0 mg/kg)	38.7 ± 3.9	50.6%	
IL-5	Control	25.4 ± 2.9	-
OVA Model	85.2 ± 6.3	-	
Renifolin F (1.5 mg/kg)	60.8 ± 5.5	28.6%	
Renifolin F (3.0 mg/kg)	42.1 ± 4.7	50.6%	
IL-9	Control	17.8 ± 2.3	-
OVA Model	59.6 ± 4.8	-	
Renifolin F (1.5 mg/kg)	41.2 ± 3.9	30.9%	
Renifolin F (3.0 mg/kg)	28.5 ± 3.1	52.2%	
IL-13	Control	28.1 ± 3.1	-
OVA Model	92.7 ± 7.5	-	
Renifolin F (1.5 mg/kg)	65.4 ± 6.1	29.4%	
Renifolin F (3.0 mg/kg)	45.9 ± 5.3	50.5%	

## Experimental Protocols

### Protocol 1: Kinase Selectivity Profiling

This protocol describes a general method for assessing the off-target effects of **Renifolin F** against a broad panel of kinases.

- Objective: To identify unintended inhibitory or activating effects of **Renifolin F** on a diverse range of human kinases.

- Materials:
  - **Renifolin F** (high purity)
  - DMSO (cell culture grade)
  - Kinase profiling service (e.g., services offered by companies like AssayQuant, BPS Bioscience, or Pharmaron which provide panels of hundreds of kinases).[\[7\]](#)[\[9\]](#)[\[12\]](#)
  - Kinase assay buffer
  - ATP
  - Substrate peptides for each kinase
- Procedure:
  1. Prepare a 10 mM stock solution of **Renifolin F** in DMSO.
  2. Submit the compound to a kinase profiling service. Typically, the service will perform the following steps: a. A primary screen is conducted at a single high concentration of **Renifolin F** (e.g., 10  $\mu$ M) against the entire kinase panel. b. Kinase activity is measured, often using methods that detect the amount of ADP produced (e.g., ADP-Glo) or the phosphorylation of a substrate.[\[8\]](#) c. Results are expressed as a percentage of inhibition or activation relative to a vehicle control (DMSO).
  3. For any "hits" identified in the primary screen (e.g., >50% inhibition), a secondary screen is performed to determine the IC<sub>50</sub> value. This involves a multi-point dose-response curve of **Renifolin F**.
- Data Analysis: The results will be provided by the service, typically including a list of kinases inhibited by **Renifolin F** and their corresponding IC<sub>50</sub> values. This data is crucial for identifying potential off-target liabilities.

#### Protocol 2: Cellular Thermal Shift Assay (CETSA) for Target Identification

This protocol provides a method to identify the direct binding targets of **Renifolin F** in an unbiased manner within intact cells.[\[10\]](#)[\[11\]](#)

- Objective: To identify proteins that are thermally stabilized upon direct binding of **Renifolin F** in a cellular context.
- Materials:
  - Cell line of interest (e.g., a human bronchial epithelial cell line or primary ILC2s)
  - **Renifolin F**
  - DMSO
  - Cell culture medium
  - Phosphate-buffered saline (PBS)
  - Protease inhibitor cocktail
  - Equipment for heating cell lysates (e.g., PCR thermocycler)
  - Equipment for protein quantification (e.g., Western blot apparatus or mass spectrometer)
- Procedure:
  1. Culture cells to ~80% confluency.
  2. Treat one set of cells with **Renifolin F** at a concentration known to be effective (e.g., 10x EC50) and another set with DMSO (vehicle control) for a specified time (e.g., 1-2 hours).
  3. Harvest the cells, wash with PBS, and resuspend in PBS with a protease inhibitor cocktail.
  4. Aliquot the cell suspension into PCR tubes.
  5. Heat the aliquots to a range of temperatures (e.g., 40°C to 70°C in 2°C increments) for 3 minutes, followed by cooling for 3 minutes at room temperature.
  6. Lyse the cells by freeze-thawing (e.g., three cycles of freezing in liquid nitrogen and thawing at room temperature).

7. Separate the soluble protein fraction from the precipitated protein by centrifugation at high speed (e.g., 20,000 x g for 20 minutes at 4°C).
  8. Collect the supernatant (soluble fraction) and analyze the protein content. This can be done for a specific candidate protein by Western blot or for a global analysis of the proteome by mass spectrometry.
- Data Analysis:
    - Western Blot: Quantify the band intensity for the protein of interest at each temperature for both the **Renifolin F**-treated and DMSO-treated samples. A shift in the melting curve to a higher temperature in the presence of **Renifolin F** indicates direct binding and stabilization.
    - Mass Spectrometry: A proteome-wide analysis will identify all proteins that show increased thermal stability in the presence of **Renifolin F**, providing a comprehensive list of potential on- and off-targets.

## Mandatory Visualization

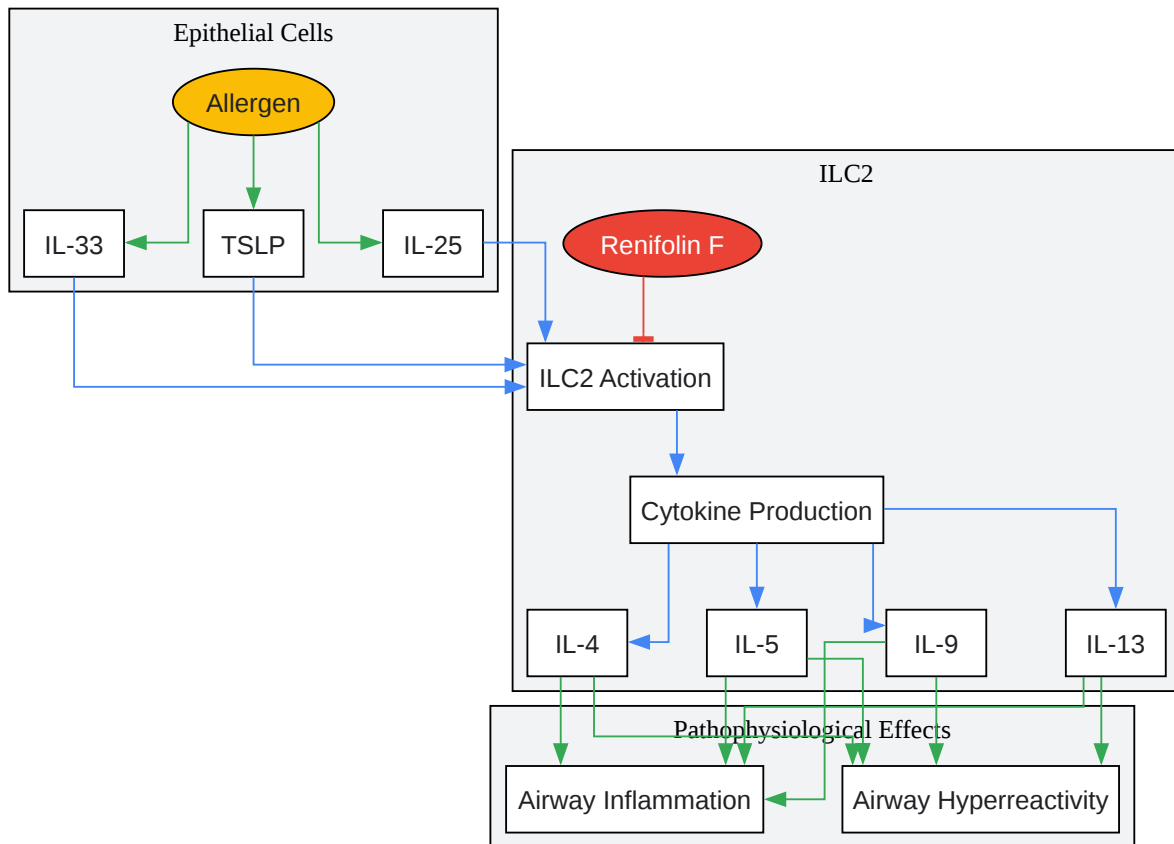

[Click to download full resolution via product page](#)

Caption: Proposed signaling pathway for **Renifolin F** in allergic airway inflammation.

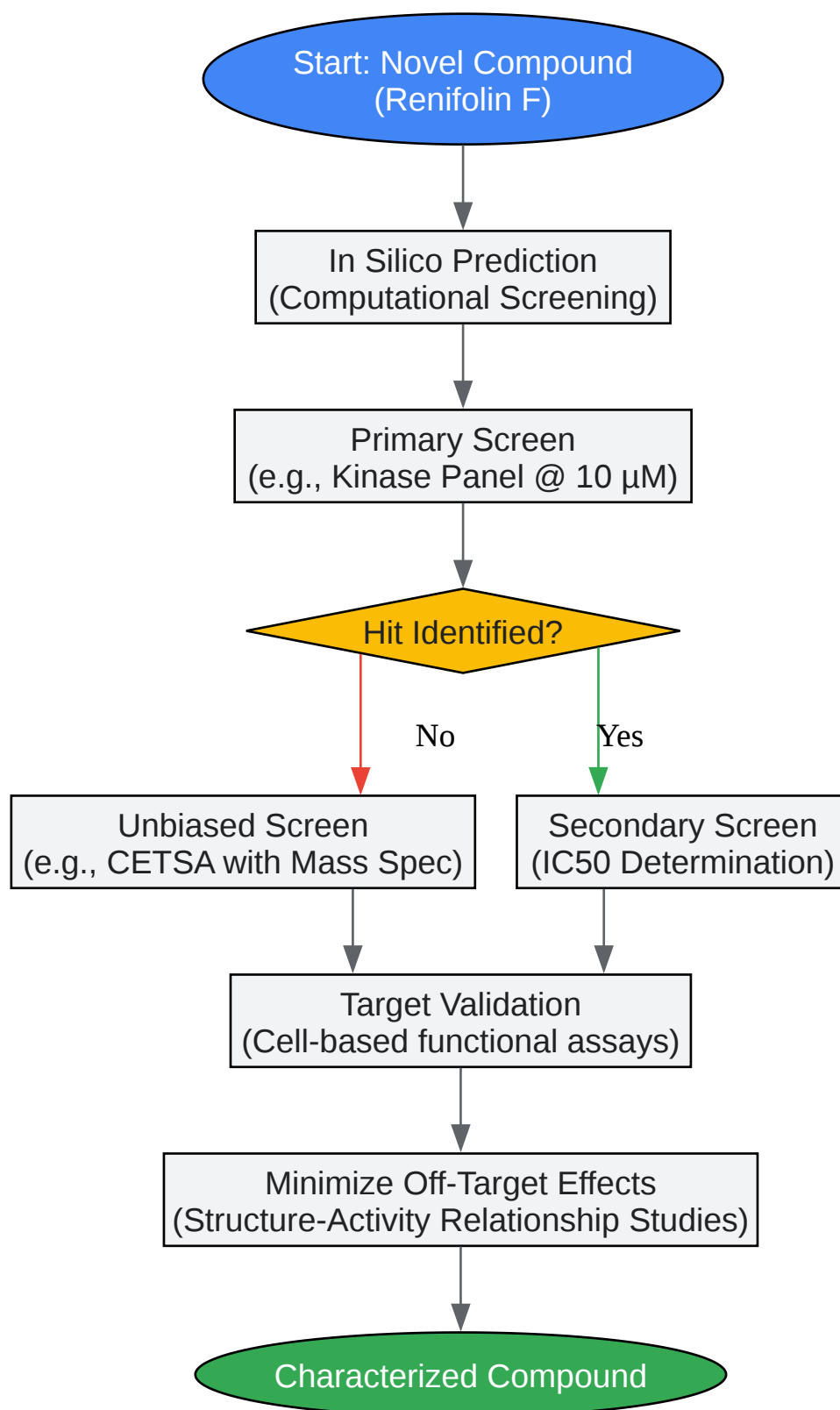

[Click to download full resolution via product page](#)

Caption: A general experimental workflow for identifying and minimizing off-target effects.

### Need Custom Synthesis?

BenchChem offers custom synthesis for rare earth carbides and specific isotopic labeling.

Email: [info@benchchem.com](mailto:info@benchchem.com) or [Request Quote Online](#).

## References

- 1. Therapeutic Effect of Renifolin F on Airway Allergy in an Ovalbumin-Induced Asthma Mouse Model In Vivo - PubMed [[pubmed.ncbi.nlm.nih.gov](https://pubmed.ncbi.nlm.nih.gov)]
- 2. Therapeutic Effect of Renifolin F on Airway Allergy in an Ovalbumin-Induced Asthma Mouse Model In Vivo - PMC [[pmc.ncbi.nlm.nih.gov](https://pmc.ncbi.nlm.nih.gov)]
- 3. Frontiers | Novel Computational Approach to Predict Off-Target Interactions for Small Molecules [[frontiersin.org](https://frontiersin.org)]
- 4. [benchchem.com](https://www.benchchem.com) [[benchchem.com](https://www.benchchem.com)]
- 5. Diverse Molecular Targets for Chalcones with Varied Bioactivities - PMC [[pmc.ncbi.nlm.nih.gov](https://pmc.ncbi.nlm.nih.gov)]
- 6. [mdpi.com](https://www.mdpi.com) [[mdpi.com](https://www.mdpi.com)]
- 7. [assayquant.com](https://www.assayquant.com) [[assayquant.com](https://www.assayquant.com)]
- 8. [kinase.logistics.com](https://www.kinase.logistics.com) [[kinase.logistics.com](https://www.kinase.logistics.com)]
- 9. [bpsbioscience.com](https://www.bpsbioscience.com) [[bpsbioscience.com](https://www.bpsbioscience.com)]
- 10. [benchchem.com](https://www.benchchem.com) [[benchchem.com](https://www.benchchem.com)]
- 11. Screening for Target Engagement using the Cellular Thermal Shift Assay - CETSA - Assay Guidance Manual - NCBI Bookshelf [[ncbi.nlm.nih.gov](https://ncbi.nlm.nih.gov)]
- 12. [pharmaron.com](https://www.pharmaron.com) [[pharmaron.com](https://www.pharmaron.com)]
- To cite this document: BenchChem. [Identifying and minimizing off-target effects of Renifolin F.]. BenchChem, [2026]. [Online PDF]. Available at: [<https://www.benchchem.com/product/b12323878/docs#identifying-and-minimizing-off-target-effects-of-renifolin-f>]

---

### Disclaimer & Data Validity:

The information provided in this document is for Research Use Only (RUO) and is strictly not intended for diagnostic or therapeutic procedures. While BenchChem strives to provide accurate protocols, we make no warranties, express or implied, regarding the fitness of this product for every specific experimental setup.

**Technical Support:** The protocols provided are for reference purposes. Unsure if this reagent suits your experiment?

**Need Industrial/Bulk Grade?** [Request Custom Synthesis Quote](#)

## BenchChem

Our mission is to be the trusted global source of essential and advanced chemicals, empowering scientists and researchers to drive progress in science and industry.

### Contact

Address: 3281 E Guasti Rd  
Ontario, CA 91761, United States  
Phone: (601) 213-4426  
Email: [info@benchchem.com](mailto:info@benchchem.com)

[Contact our Ph.D. Support Team for a compatibility check](#)