

# Technical Guide: Improving Sensitivity for Low-Level Detection of N'-Desmethyl Azithromycin

**Author:** BenchChem Technical Support Team. **Date:** May 2026

## Compound of Interest

Compound Name: *N'-Desmethyl Azithromycin*

Cat. No.: *B12321954*

[Get Quote](#)

## Introduction

**N'-Desmethyl Azithromycin** (also known as 3'-N-desmethyl azithromycin) is a primary metabolite of the macrolide antibiotic Azithromycin. While the parent drug is abundant, the metabolite often presents at significantly lower concentrations, demanding high-sensitivity assays (LLOQ < 1.0 ng/mL).

This guide addresses the three critical bottlenecks in analyzing this compound: adsorption (stickiness), ion suppression (matrix effects), and chromatographic carryover.

## Module 1: Sample Preparation (The "Clean-Up" Phase)

### Core Challenge: Non-Specific Binding & Matrix Interference

Macrolides are lipophilic and basic (pKa ~8.7). They bind aggressively to glass surfaces and residual silanols, leading to poor recovery and non-linear calibration curves at low

concentrations. Furthermore, protein precipitation (PPT) often fails to remove phospholipids, which co-elute and suppress ionization in ESI+ mode.

## Recommended Protocol: Solid Phase Extraction (SPE)

For low-level detection (<1 ng/mL), SPE is superior to Liquid-Liquid Extraction (LLE) or PPT due to its ability to concentrate the sample and remove phospholipids.

Optimized SPE Workflow (Oasis HLB or Equivalent):

- Sample Pre-treatment:
  - Mix 100  $\mu$ L Plasma with 200  $\mu$ L 2% Phosphoric Acid ( $H_3PO_4$ ).
  - Why? Acidification breaks protein binding and ionizes the basic amine, preventing adsorption to the container walls before loading.
- Conditioning:
  - 1 mL Methanol followed by 1 mL Water.
- Loading:
  - Load pre-treated sample slowly (gravity or low vacuum).
- Washing (Critical Step):
  - Wash 1: 1 mL 5% Methanol in Water (Removes salts/proteins).
  - Wash 2: 1 mL 2% Formic Acid in 20% Acetonitrile (Removes phospholipids).
- Elution:
  - Elute with 500  $\mu$ L Acetonitrile/Methanol (1:1).
- Reconstitution:
  - Evaporate under  $N_2$  at 40°C. Reconstitute in mobile phase (e.g., 20% ACN in 0.1% Formic Acid).

- Note: Use Polypropylene (PP) vials only. Do not use glass inserts.

## Troubleshooting Q&A

Q: My recovery is consistently low (<50%), even with SPE.

- Root Cause: Adsorption to labware.
- Fix: Switch all preparation tubes, reservoirs, and autosampler vials to low-bind polypropylene. If glass must be used, silanize it. Ensure the elution solvent is strong enough (100% organic) to desorb the analyte from the sorbent.

Q: I see high variability between replicates.

- Root Cause: Inconsistent pH during loading.
- Fix: Ensure the sample pH is acidic (pH < 3) during loading. If the pH is near the pKa (8.7), the analyte exists as a mix of ionized and neutral forms, leading to variable retention on the SPE cartridge.

## Module 2: LC-MS/MS Optimization (The "Detection" Phase)

### Chromatographic Strategy

Separation must resolve the metabolite from the parent (Azithromycin) and isobaric interferences. A C18 column is standard, but a PFP (Pentafluorophenyl) column can offer alternate selectivity if matrix peaks interfere.

Recommended System:

- Column: ACE C18 or Hypersil GOLD C18 (2.1 x 50 mm, 1.9  $\mu$ m).
- Mobile Phase A: 0.1% Formic Acid in Water (or 10mM Ammonium Formate pH 4.0).
- Mobile Phase B: Acetonitrile/Methanol (50:50) + 0.1% Formic Acid.[\[1\]](#)[\[2\]](#)[\[3\]](#)[\[4\]](#)

- Insight: Mixing MeOH and ACN often improves peak shape for macrolides compared to ACN alone.

## Mass Spectrometry Parameters (ESI+)

The N'-desmethyl metabolite (MW ~734) is detected as the singly charged protonated ion

Table 1: Optimized MRM Transitions

Analyte	Precursor Ion (m/z)	Product Ion (m/z)	Cone Voltage (V)	Collision Energy (eV)	Mechanism
Azithromycin	749.5	591.5	30	28	Loss of Cladinose (-158)
N'-Desmethyl Azithromycin	735.5	577.5	30	30	Loss of Cladinose (-158)
Azithromycin-d5 (IS)	754.5	596.5	30	28	Loss of Cladinose (-158)

Note: The transition 735.5 -> 577.5 corresponds to the neutral loss of the cladinose sugar (158 Da), which is the most abundant fragmentation pathway for this class of macrolides.

## Visualizing the Workflow

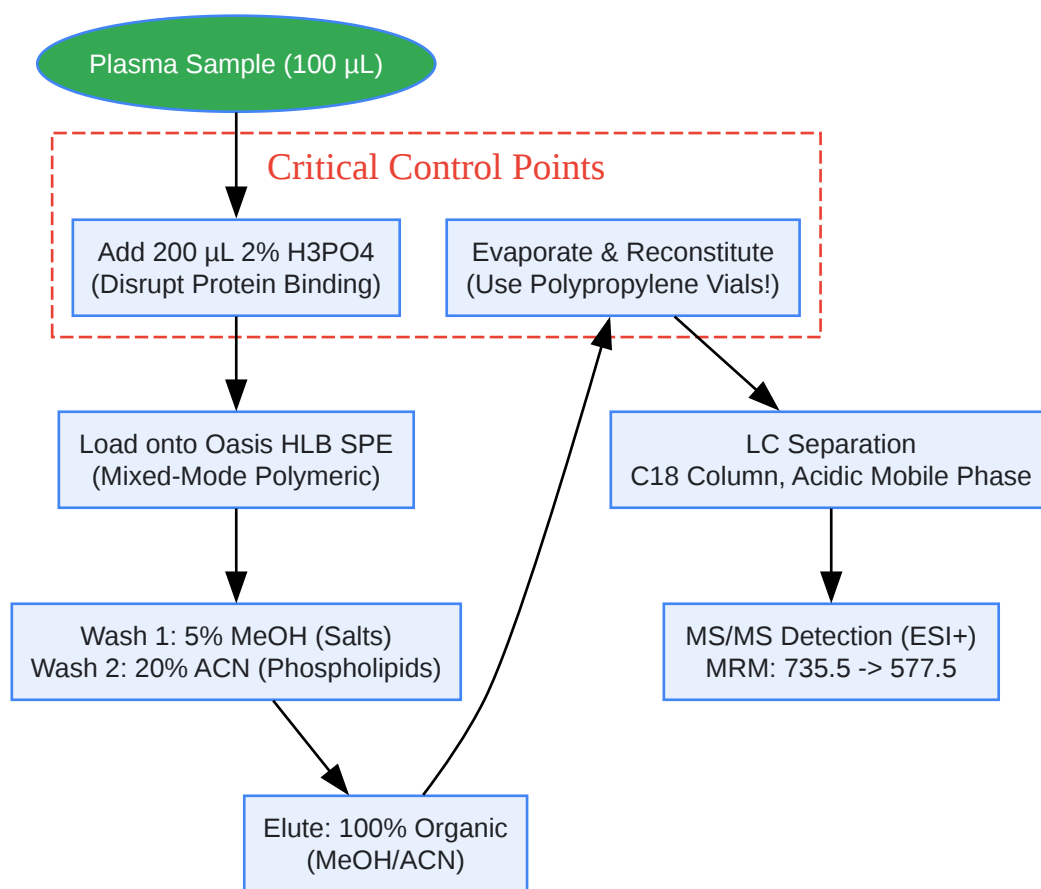

[Click to download full resolution via product page](#)

Figure 1: Optimized Bioanalytical Workflow for **N'-Desmethyl Azithromycin**. Critical control points for preventing adsorption are highlighted.

## Module 3: Troubleshooting Guide

### Issue 1: High Carryover in Blank Samples

Symptom: A peak appears in the blank injection immediately following a high-concentration standard (ULOQ).

- Mechanism: Macrolides are "sticky" bases. They adsorb to the injection needle, valve rotor, and column frit.
- Solution:
  - Needle Wash: Use a dual-wash system.

- Weak Wash: 90% Water / 10% ACN (0.1% Formic Acid).
- Strong Wash: 40% ACN / 40% MeOH / 20% Isopropanol / 0.1% Formic Acid. (The IPA helps solubilize the lipophilic macrolide).
- Column: Use a guard column and replace it frequently.

## Issue 2: Signal Suppression (Matrix Effect)

Symptom: Internal Standard (IS) response drops significantly in patient samples compared to neat standards.

- Mechanism: Co-eluting phospholipids compete for charge in the ESI source.
- Solution:
  - Monitor Phospholipids: Add a trace for m/z 184 → 184 (phosphatidylcholine) to see where they elute.
  - Adjust Gradient: Ensure the metabolite elutes before the phospholipid wash-out phase.
  - Switch to SPE: If using Protein Precipitation, switch to SPE (as detailed in Module 1) to physically remove lipids.

## Issue 3: Peak Tailing

Symptom: Asymmetrical peaks with a long tail, reducing S/N ratio.

- Mechanism: Interaction between the basic amine of the metabolite and residual silanols on the silica column.
- Solution:
  - Mobile Phase Additive: Ensure at least 10mM Ammonium Formate or 0.1% Formic Acid is present.
  - Column Choice: Use an "end-capped" C18 column or a column designed for high pH stability (e.g., Waters XBridge) if you wish to run at pH 10 (though acidic pH is preferred for ESI+ sensitivity).

## References

- Zhang, Y., et al. (2022). "A simple, high-throughput and validated LC-MS/MS method for the determination of azithromycin in human plasma and its application to a clinical pharmacokinetic study." Biomedical Chromatography. [Link](#)
- Chen, B., et al. (2006).[5] "Quantitative determination of azithromycin in human plasma by liquid chromatography-mass spectrometry and its application in a bioequivalence study." Journal of Pharmaceutical and Biomedical Analysis. [Link](#)
- Sultana, T.A., et al. (2025). "Quantitative Determination of Azithromycin in Human Plasma by Liquid Chromatography–Mass Spectrometry." ResearchGate.[2][6] [Link](#)
- Alwsci Technologies. (2025).[7] "SPE Vs. LLE: Choosing The Right Extraction Technique." Alwsci.com. [Link](#)

### Need Custom Synthesis?

BenchChem offers custom synthesis for rare earth carbides and specific isotopic labeling.

Email: [info@benchchem.com](mailto:info@benchchem.com) or [Request Quote Online](#).

## Sources

- 1. A simple, high-throughput and validated LC–MS/MS method for the determination of azithromycin in human plasma and its application to a clinical pharmacokinetic study - PMC [[pubmed.ncbi.nlm.nih.gov](https://pubmed.ncbi.nlm.nih.gov)]
- 2. researchgate.net [[researchgate.net](https://researchgate.net)]
- 3. A simple, high-throughput and validated LC-MS/MS method for the determination of azithromycin in human plasma and its application to a clinical pharmacokinetic study - PubMed [[pubmed.ncbi.nlm.nih.gov](https://pubmed.ncbi.nlm.nih.gov)]
- 4. A simple, high-throughput and validated LC-MS/MS method for the determination of azithromycin in human plasma and its application to a clinical pharmacokinetic study - PubMed [[pubmed.ncbi.nlm.nih.gov](https://pubmed.ncbi.nlm.nih.gov)]
- 5. Quantitative determination of azithromycin in human plasma by liquid chromatography-mass spectrometry and its application in a bioequivalence study - PubMed [[pubmed.ncbi.nlm.nih.gov](https://pubmed.ncbi.nlm.nih.gov)]

- [6. researchgate.net \[researchgate.net\]](#)
- [7. SPE Vs. LLE: Choosing The Right Extraction Technique Can Make Or Break Your Results - Blogs - News \[alwsci.com\]](#)
- To cite this document: BenchChem. [Technical Guide: Improving Sensitivity for Low-Level Detection of N'-Desmethyl Azithromycin]. BenchChem, [2026]. [Online PDF]. Available at: [<https://www.benchchem.com/product/b12321954/docs#technical-guide-improving-sensitivity-for-low-level-detection-of-n-desmethyl-azithromycin>]

---

### Disclaimer & Data Validity:

The information provided in this document is for Research Use Only (RUO) and is strictly not intended for diagnostic or therapeutic procedures. While BenchChem strives to provide accurate protocols, we make no warranties, express or implied, regarding the fitness of this product for every specific experimental setup.

**Technical Support:** The protocols provided are for reference purposes. Unsure if this reagent suits your experiment?

**Need Industrial/Bulk Grade?** [Request Custom Synthesis Quote](#)

## BenchChem

Our mission is to be the trusted global source of essential and advanced chemicals, empowering scientists and researchers to drive progress in science and industry.

### Contact

Address: 3281 E Guasti Rd  
Ontario, CA 91761, United States  
Phone: (601) 213-4426  
Email: [info@benchchem.com](mailto:info@benchchem.com)

[Contact our Ph.D. Support Team for a compatibility check](#)

