

Potential off-target effects of L-687,414

Author: BenchChem Technical Support Team. **Date:** April 2026

Compound of Interest

Compound Name: L-687414
Cat. No.: B12321378

[Get Quote](#)

Technical Support Center: L-687,414

This technical support center provides troubleshooting guides and frequently asked questions (FAQs) for researchers, scientists, and drug development professionals using L-687,414. The information is presented in a question-and-answer format to directly address specific issues that may be encountered during experiments.

Frequently Asked Questions (FAQs)

Q1: What is the primary mechanism of action of L-687,414?

L-687,414 is primarily characterized as a selective antagonist or a low-efficacy partial agonist at the glycine co-agonist site of the N-methyl-D-aspartate (NMDA) receptor.[1] Its function is to modulate the activity of the NMDA receptor, a key player in synaptic plasticity and neurotransmission.

Q2: Are there any known off-target effects of L-687,414?

While comprehensive public data on the off-target binding profile of L-687,414 is limited, preclinical studies suggest potential interactions with other signaling pathways. The hyperlocomotor effects induced by L-687,414 in animal models can be reversed by agonists of the Trace Amine-Associated Receptor 1 (TAAR1) and inhibitors of the Glycine Transporter 1

(GlyT1).[2] This suggests a functional interaction with these pathways, although direct binding affinity data (K_i or IC₅₀ values) for L-687,414 at TAAR1 and GlyT1 are not readily available in public databases.

Q3: What are the potential therapeutic applications of L-687,414?

As a modulator of the NMDA receptor, L-687,414 has been investigated for its potential neuroprotective effects. Its ability to attenuate NMDA receptor overactivation without causing the vacuolization in the brain seen with some other NMDA antagonists makes it a compound of interest in research settings.[1]

Troubleshooting Guide

Observed Issue	Potential Cause	Recommended Action
Unexpected behavioral effects (e.g., hyperlocomotion) in animal models.	This may be an on-target effect of NMDA receptor antagonism or a potential off-target effect related to the dopaminergic or TAAR1 signaling pathways.[2]	Consider co-administration with a TAAR1 agonist or a GlyT1 inhibitor to investigate the involvement of these pathways. Monitor dopamine levels in relevant brain regions.
Variability in experimental results.	Inconsistent compound purity, stability, or concentration. Pipetting errors or issues with cell culture conditions.	Ensure the quality and purity of the L-687,414 stock. Prepare fresh solutions for each experiment. Calibrate pipettes and maintain consistent cell culture conditions. Include appropriate positive and negative controls.
Difficulty replicating published findings.	Differences in experimental protocols, animal strains, or cell lines.	Carefully review and compare your experimental setup with the published methodology. Pay close attention to details such as vehicle, route of administration, and timing of measurements.

Data Presentation

A comprehensive quantitative off-target binding profile for L-687,414 is not publicly available at this time. Researchers are advised to perform their own selectivity profiling against a panel of relevant receptors and kinases to determine the off-target interaction profile for their specific experimental context. Below is a template table that can be used to summarize such findings.

Table 1: Hypothetical Off-Target Binding Profile of L-687,414

Target	Assay Type	Ki (nM)	IC50 (nM)	% Inhibition @ 1µM
NMDA (Glycine Site)	Radioligand Binding	Value	Value	Value
TAAR1	Radioligand Binding	Value	Value	Value
GlyT1	Functional Assay	Value	Value	Value
Kinase Panel (e.g., CAMKII, PKA, PKC)	Kinase Assay	Value	Value	Value
Other GPCRs	Radioligand Binding	Value	Value	Value

Experimental Protocols

Protocol 1: Radioligand Binding Assay for Off-Target Assessment

This protocol provides a general framework for assessing the binding affinity of L-687,414 to a panel of G-protein coupled receptors (GPCRs) and transporters.

1. Materials:

- L-687,414
- Cell membranes expressing the target receptor of interest

- Radioligand specific for the target receptor
- Assay buffer (e.g., 50 mM Tris-HCl, 120 mM NaCl, 5 mM KCl, 2 mM CaCl₂, 1 mM MgCl₂, pH 7.4)
- Non-specific binding inhibitor (a high concentration of a known ligand for the target)
- 96-well plates
- Scintillation fluid and counter

2. Procedure:

- Prepare serial dilutions of L-687,414 in assay buffer.
- In a 96-well plate, add assay buffer, the radioligand at a concentration near its K_d, and either vehicle, a concentration of L-687,414, or the non-specific binding inhibitor.
- Add the cell membrane preparation to initiate the binding reaction.
- Incubate the plate at room temperature for a predetermined time to reach equilibrium.
- Terminate the reaction by rapid filtration through a glass fiber filter mat to separate bound from free radioligand.
- Wash the filters with ice-cold assay buffer.
- Add scintillation fluid to the filters and count the radioactivity using a scintillation counter.

3. Data Analysis:

- Calculate the specific binding by subtracting the non-specific binding from the total binding.
- Plot the specific binding as a function of the L-687,414 concentration.
- Determine the IC₅₀ value using non-linear regression analysis.
- Calculate the K_i value using the Cheng-Prusoff equation: $K_i = IC_{50} / (1 + [L]/K_d)$, where [L] is the concentration of the radioligand and K_d is its dissociation constant.

Protocol 2: Kinase Inhibitor Profiling Assay

This protocol outlines a general method for screening L-687,414 against a panel of kinases to identify potential off-target kinase inhibition.

1. Materials:

- L-687,414
- A panel of purified kinases
- Kinase-specific substrates
- ATP (often radiolabeled, e.g., [γ -³³P]ATP)
- Kinase reaction buffer

- 96-well plates
- Phosphocellulose filter paper or other method for capturing phosphorylated substrate
- Scintillation counter or appropriate detection instrument

2. Procedure:

- Prepare dilutions of L-687,414 in the kinase reaction buffer.
- In a 96-well plate, add the kinase, its specific substrate, and either vehicle or a concentration of L-687,414.
- Initiate the kinase reaction by adding ATP.
- Incubate the plate at 30°C for a specified time.
- Stop the reaction (e.g., by adding a stop solution like phosphoric acid).
- Spot the reaction mixture onto phosphocellulose filter paper to capture the phosphorylated substrate.
- Wash the filter paper to remove unincorporated ATP.
- Quantify the amount of phosphorylated substrate using a scintillation counter or other appropriate detection method.

3. Data Analysis:

- Calculate the percentage of kinase activity remaining at each concentration of L-687,414 relative to the vehicle control.
- Plot the percentage of kinase activity as a function of the L-687,414 concentration.
- Determine the IC₅₀ value for any kinases that show significant inhibition.

Visualizations

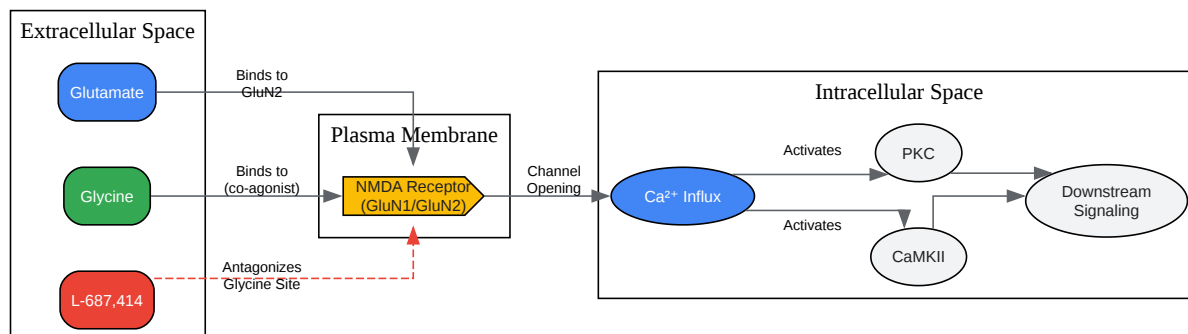

[Click to download full resolution via product page](#)

Caption: NMDA Receptor Signaling Pathway and the Action of L-687,414.

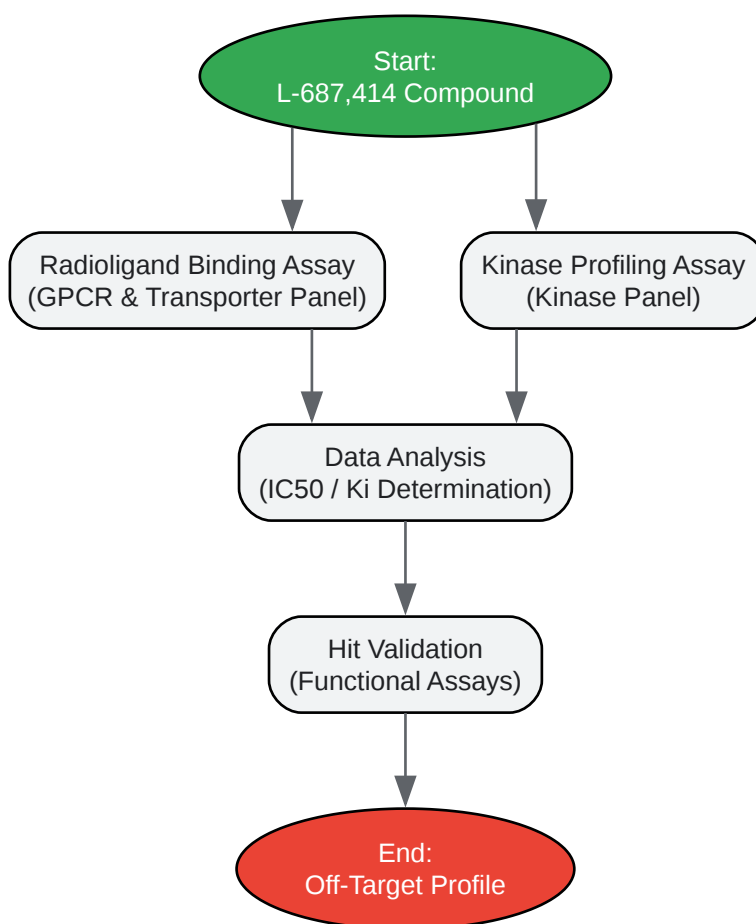

[Click to download full resolution via product page](#)

Caption: Experimental Workflow for Off-Target Profiling of L-687,414.

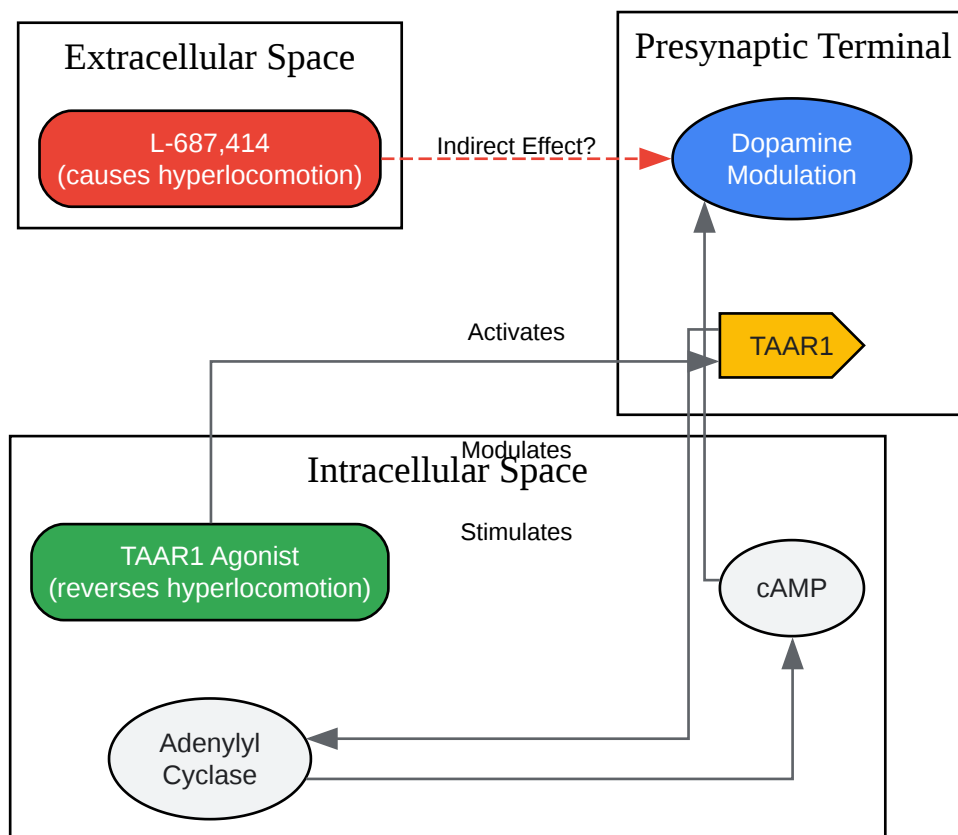

[Click to download full resolution via product page](#)

Caption: Hypothesized TAAR1 Involvement in L-687,414-Induced Hyperlocomotion.

Need Custom Synthesis?

BenchChem offers custom synthesis for rare earth carbides and specific isotopic labeling.

Email: info@benchchem.com or [Request Quote Online](#).

References

- 1. Pharmacology of NMDA Receptors - Biology of the NMDA Receptor - NCBI Bookshelf [[ncbi.nlm.nih.gov](https://www.ncbi.nlm.nih.gov)]

- [2. Potential of Ligands for Trace Amine-Associated Receptor 1 \(TAAR1\) in the Management of Substance Use Disorders - PMC \[pmc.ncbi.nlm.nih.gov\]](#)
- To cite this document: BenchChem. [Potential off-target effects of L-687,414]. BenchChem, [2026]. [Online PDF]. Available at: [\[https://www.benchchem.com/product/b12321378/docs#potential-off-target-effects-of-l-687-414\]](https://www.benchchem.com/product/b12321378/docs#potential-off-target-effects-of-l-687-414)

Disclaimer & Data Validity:

The information provided in this document is for Research Use Only (RUO) and is strictly not intended for diagnostic or therapeutic procedures. While BenchChem strives to provide accurate protocols, we make no warranties, express or implied, regarding the fitness of this product for every specific experimental setup.

Technical Support: The protocols provided are for reference purposes. Unsure if this reagent suits your experiment?

Need Industrial/Bulk Grade? [Request Custom Synthesis Quote](#)

BenchChem

Our mission is to be the trusted global source of essential and advanced chemicals, empowering scientists and researchers to drive progress in science and industry.

Contact

Address: 3281 E Guasti Rd
Ontario, CA 91761, United States
Phone: (601) 213-4426
Email: info@benchchem.com

[Contact our Ph.D. Support Team for a compatibility check](#)