

Technical Guide: Optimizing Incubation Times for Butaclamol Competition Assays

Author: BenchChem Technical Support Team. **Date:** May 2026

Compound of Interest

Compound Name: (-)-Butaclamol hcl

Cat. No.: B12320171

[Get Quote](#)

To: Research Scientists & Assay Development Leads From: Senior Application Scientist, Ligand Binding Unit Subject: Achieving Thermodynamic Equilibrium in Dopamine Receptor Competition Assays

Introduction: The Equilibrium Imperative

In radioligand competition assays, particularly those utilizing Butaclamol to characterize Dopamine receptors (D1/D2), incubation time is not merely a logistical step—it is a thermodynamic variable that dictates the accuracy of your affinity constants (

).

A common misconception is that incubation time should simply match the time required for the radioligand to reach steady state. This is incorrect. In a competition assay, the system must reach a global equilibrium where both the radioligand and the competitor (Butaclamol) have stabilized their occupancy ratios.

If you terminate the assay too early (pre-equilibrium), you risk observing a "Rightward Shift" in your

values, artificially inflating the calculated

and underestimating the affinity of Butaclamol. Conversely, excessive incubation risks receptor degradation and ligand depletion.

This guide provides a self-validating framework to determine the precise incubation window for your specific receptor-ligand system.

The Kinetic Theory (The "Why")

The interaction between the Receptor (

), the Radioligand (

), and the Competitor (

- Butaclamol) is governed by the Law of Mass Action.

The Motulsky-Mahan Rule

According to the seminal work by Motulsky and Mahan (1984), the time to reach equilibrium in a competition assay is determined primarily by the dissociation rate constant (

) of the slower-dissociating ligand.

- Scenario A: If Butaclamol dissociates slower than the radioligand, the incubation time depends on Butaclamol's kinetics.
- Scenario B: If the radioligand (e.g.,
-SCH23390 or
-Spiperone) dissociates slower, the incubation time is dictated by the radioligand's

Failure to account for this results in "kinetic shifts" where

values change over time.

Visualizing the Competitive Dynamic[1][2][3]

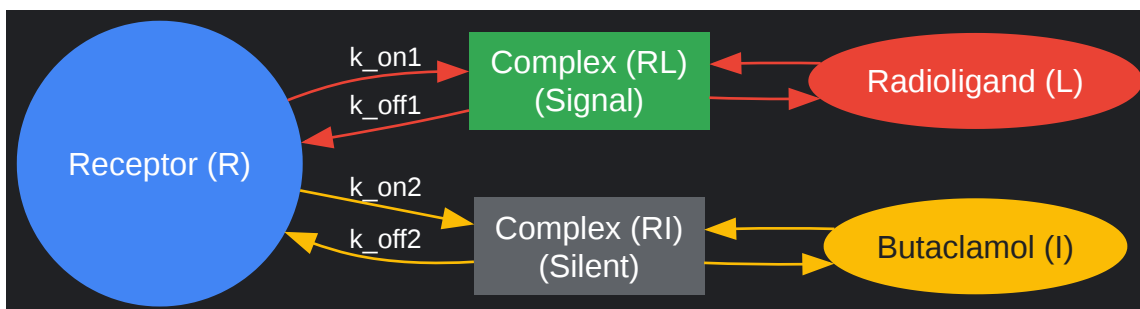

[Click to download full resolution via product page](#)

Figure 1: Competitive binding kinetics. Equilibrium is reached only when the rates of formation and dissociation for both RL (Signal) and RI (Silent) complexes stabilize.

Protocol: The Time-Course Optimization Experiment

Do not guess your incubation time. Perform this validation experiment once per new receptor batch or radioligand lot.

Experimental Design

- Radioligand: Fixed concentration (approx. equal to its K_d).
- Competitor: Butaclamol at a fixed concentration equal to its expected K_d (or $10 \times K_d$).
- Variable: Time (t).

Step-by-Step Methodology

- Preparation: Prepare a master mix of membrane homogenate.
- Staggered Start (Reverse Time Course):

- To ensure all samples are filtered simultaneously (reducing variability), add ligands at different times.
- Example: For a 2-hour window, start the

min tubes first. Start the

min tubes last.
- Incubation Conditions:
 - Maintain constant temperature (usually 25°C or 37°C).[6]
 - Note: Butaclamol is lipophilic; ensure low-binding plastics are used to prevent depletion.
- Termination:
 - Rapid filtration through GF/B filters (pre-soaked in 0.3% PEI to reduce NSB).
- Data Analysis:
 - Plot Specific Binding (CPM) vs. Time (min).
 - Fit to a "One-phase association" model.

Workflow Diagram

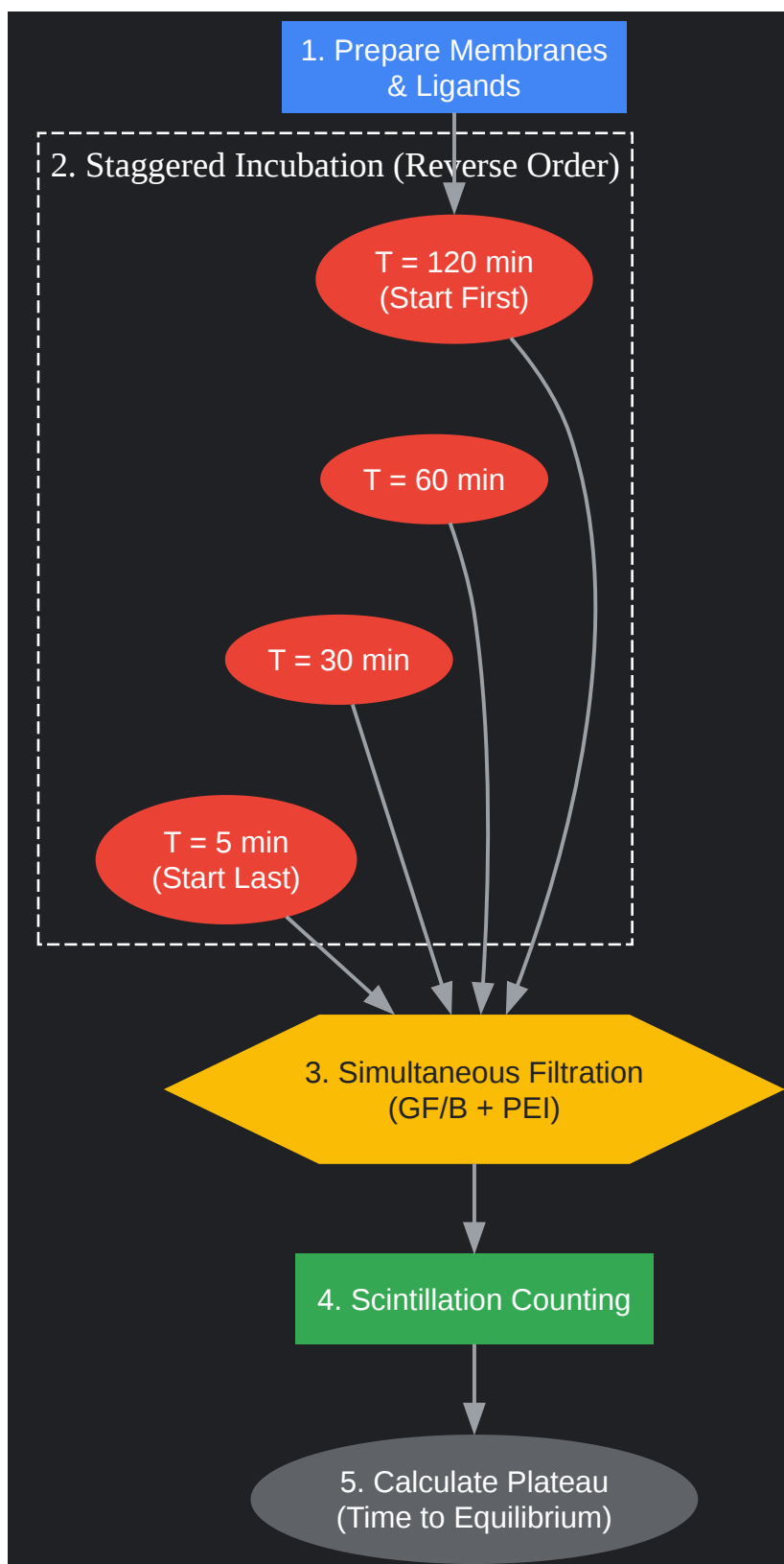

[Click to download full resolution via product page](#)

Figure 2: Reverse Time-Course Workflow. Staggering start times allows for simultaneous termination, minimizing filtration variability.

Troubleshooting & FAQs

Q1: Why does my Butaclamol shift to the left as I increase incubation time?

A: This is a classic sign of non-equilibrium. If the competitor (Butaclamol) associates slowly or the radioligand dissociates slowly, early time points will reflect the "on-rate" advantage of the radioligand rather than the true thermodynamic affinity of Butaclamol.

- Solution: Extend incubation time until the

stabilizes between two consecutive time points (e.g., 90 min and 120 min yield the same value).

Q2: How do I define Non-Specific Binding (NSB) correctly with Butaclamol?

A: Stereoselectivity is the gold standard for Dopamine receptors.

- (+)-Butaclamol: Active enantiomer. Blocks specific D1/D2 receptors.
- (-)-Butaclamol: Inactive enantiomer.^{[7][8]} Does not bind specific receptors but mimics the physicochemical "stickiness" of the active drug.
- Protocol: Define Specific Binding as:

Alternatively, use 1 μ M (+)-Butaclamol to define NSB, as it displaces all specific radioligand.

Q3: My total counts drop significantly after 2 hours. Is this a problem?

A: Yes. This indicates receptor instability or ligand degradation. If the signal drops, the

(total receptor number) is effectively changing during the assay, violating the assumptions of the competition isotherm.

- Solution:
 - Add protease inhibitors to the buffer.
 - Lower the temperature (e.g., 37°C 25°C). Note that lowering temperature slows kinetics, so you will need to extend incubation time further.[\[6\]](#)[\[9\]](#)

Data Analysis: The Stability Matrix

Use the table below to interpret your time-course data.

Observation	Diagnosis	Action Required
decreases over time	Pre-equilibrium	Increase incubation time.
increases over time	Ligand depletion or degradation	Check stability; Decrease receptor concentration.
Stable (+/- 10%)	Equilibrium Reached	Optimal incubation time identified.
High NSB (>50%)	"Sticky" Ligand	Use 0.3% PEI on filters; switch to silanized tubes.

References

- Motulsky, H. J., & Mahan, L. C. (1984). The kinetics of competitive radioligand binding predicted by the law of mass action.[\[10\]](#) *Molecular Pharmacology*, 25(1), 1-9.
- Seeman, P., et al. (1975). Brain receptors for antipsychotic drugs and dopamine: direct binding assays.[\[7\]](#) *Proceedings of the National Academy of Sciences*, 72(11), 4376-4380.[\[7\]](#)
- Burt, D. R., Creese, I., & Snyder, S. H. (1976). Properties of [³H]haloperidol and [³H]dopamine binding associated with dopamine receptors in calf brain membranes. *Molecular Pharmacology*, 12(5), 800-812.

- International Union of Basic and Clinical Pharmacology (IUPHAR). Receptor Binding Assay Guidelines.

Need Custom Synthesis?

BenchChem offers custom synthesis for rare earth carbides and specific isotopic labeling.

Email: info@benchchem.com or [Request Quote Online](#).

Sources

- [1. Analyzing Kinetic Binding Data - Assay Guidance Manual - NCBI Bookshelf \[ncbi.nlm.nih.gov\]](#)
- [2. researchgate.net \[researchgate.net\]](#)
- [3. bmglabtech.com \[bmglabtech.com\]](#)
- [4. graphpad.com \[graphpad.com\]](#)
- [5. Optimum Conditions of Radioligand Receptor Binding Assay of Ligands of Benzodiazepine Receptors - PMC \[pmc.ncbi.nlm.nih.gov\]](#)
- [6. Ligand Binding Assays: Definitions, Techniques, and Tips to Avoid Pitfalls - Fluidic Sciences Ltd % \[fluidic.com\]](#)
- [7. researchgate.net \[researchgate.net\]](#)
- [8. Brain receptors for antipsychotic drugs and dopamine: direct binding assays - PMC \[pmc.ncbi.nlm.nih.gov\]](#)
- [9. pdf.benchchem.com \[pdf.benchchem.com\]](#)
- [10. The kinetics of competitive radioligand binding predicted by the law of mass action - PubMed \[pubmed.ncbi.nlm.nih.gov\]](#)
- To cite this document: BenchChem. [Technical Guide: Optimizing Incubation Times for Butaclamol Competition Assays]. BenchChem, [2026]. [Online PDF]. Available at: [\[https://www.benchchem.com/product/b12320171/docs#technical-guide-optimizing-incubation-times-for-butaclamol-competition-assays\]](https://www.benchchem.com/product/b12320171/docs#technical-guide-optimizing-incubation-times-for-butaclamol-competition-assays)

Disclaimer & Data Validity:

The information provided in this document is for Research Use Only (RUO) and is strictly not intended for diagnostic or therapeutic procedures. While BenchChem strives to provide accurate protocols, we make no warranties, express or implied, regarding the fitness of this product for every specific experimental setup.

Technical Support: The protocols provided are for reference purposes. Unsure if this reagent suits your experiment?

Need Industrial/Bulk Grade? [Request Custom Synthesis Quote](#)

BenchChem

Our mission is to be the trusted global source of essential and advanced chemicals, empowering scientists and researchers to drive progress in science and industry.

Contact

Address: 3281 E Guasti Rd
Ontario, CA 91761, United States
Phone: (601) 213-4426
Email: info@benchchem.com

[Contact our Ph.D. Support Team for a compatibility check](#)