

K-S vs. Li-S Batteries: A Comparative Guide to Electrochemical Performance

Author: BenchChem Technical Support Team. **Date:** December 2025

Compound of Interest

Compound Name: Potassium polysulfide

Cat. No.: B1232493

[Get Quote](#)

For researchers, scientists, and professionals in battery technology, this guide provides an objective comparison of the electrochemical performance of Potassium-Sulfur (K-S) and Lithium-Sulfur (Li-S) batteries, supported by experimental data and detailed methodologies.

The quest for next-generation energy storage systems with higher energy density, lower cost, and improved safety has led to significant interest in metal-sulfur batteries. Among these, Lithium-Sulfur (Li-S) batteries have been extensively studied due to their high theoretical specific energy. More recently, Potassium-Sulfur (K-S) batteries have emerged as a promising alternative, leveraging the natural abundance and low cost of potassium. This guide delves into a detailed comparison of their electrochemical performance, providing a clear overview for researchers in the field.

Data Presentation: A Side-by-Side Look at Performance Metrics

The following table summarizes the key quantitative electrochemical performance metrics for K-S and Li-S batteries based on reported experimental data. It is important to note that these values can vary significantly depending on the specific materials, electrode design, electrolyte composition, and testing conditions.

Performance Metric	Potassium-Sulfur (K-S) Batteries	Lithium-Sulfur (Li-S) Batteries
Theoretical Specific Capacity	1675 mAh/g[1]	1675 mAh/g[2]
Practical Specific Capacity	800 - 1400 mAh/g[3]	800 - 1200 mAh/g[4]
Theoretical Energy Density	~1055 Wh/kg	~2600 Wh/kg[2][5]
Practical Energy Density	150 - 300 Wh/kg[1]	300 - 500 Wh/kg[4][6]
Operating Voltage	~1.8 V	~2.15 V[2]
Coulombic Efficiency	>95%	>98%
Cycle Life	Several hundred cycles with significant capacity fade	Up to 1500 cycles demonstrated in lab settings[2]
Polysulfide Shuttle Effect	More severe due to higher solubility of potassium polysulfides[7]	A major challenge leading to capacity decay[8][9]
Key Challenges	Severe polysulfide shuttle, large volume expansion (~296%), dendrite formation, sluggish kinetics[1]	Polysulfide shuttle, insulating nature of sulfur and Li ₂ S, lithium dendrite formation, volume expansion (~80%)[8]

Experimental Protocols: Methodologies for Evaluation

To ensure a standardized and reproducible comparison of battery performance, detailed experimental protocols are crucial. Below are typical methodologies for the fabrication and electrochemical testing of K-S and Li-S coin cells.

Cathode Preparation (General)

- **Slurry Preparation:** The active material (sulfur), a conductive agent (e.g., Super P or carbon nanotubes), and a binder (e.g., polyvinylidene fluoride - PVDF or carboxymethyl cellulose - CMC) are mixed in a specific weight ratio (e.g., 70:20:10).

- **Solvent Addition:** A suitable solvent (e.g., N-methyl-2-pyrrolidone - NMP for PVDF) is added to the mixture to form a homogeneous slurry.
- **Coating:** The slurry is uniformly cast onto a current collector (e.g., aluminum foil for Li-S, carbon-coated aluminum foil for K-S) using a doctor blade.
- **Drying:** The coated electrode is dried in a vacuum oven at a specific temperature (e.g., 60°C) for several hours to remove the solvent.
- **Electrode Punching:** Circular electrodes of a specific diameter are punched from the dried sheet.

Battery Assembly (Coin Cell - CR2032)

All assembly is performed in an argon-filled glovebox with H₂O and O₂ levels below 0.1 ppm.

- **Anode Placement:** A lithium or potassium metal disc is placed in the center of the coin cell's negative case.
- **Separator Addition:** A separator (e.g., Celgard 2400 or glass fiber) is placed on top of the anode.
- **Electrolyte Addition:** A specific volume of electrolyte is added to wet the separator and anode.
 - **Li-S Electrolyte:** Typically 1 M lithium bis(trifluoromethanesulfonyl)imide (LiTFSI) in a mixture of 1,3-dioxolane (DOL) and 1,2-dimethoxyethane (DME) (1:1 v/v) with an additive like LiNO₃.
 - **K-S Electrolyte:** For instance, 0.8 M potassium bis(fluorosulfonyl)imide (KFSI) in a mixture of DME and DOL.
- **Cathode Placement:** The prepared sulfur cathode is placed on top of the wet separator.
- **Final Assembly:** A spacer disc and a spring are placed on the cathode, and the coin cell is sealed using a crimping machine.

Electrochemical Measurements

- Resting: The assembled cells are rested for several hours to ensure complete electrolyte wetting of the electrodes.
- Cyclic Voltammetry (CV): CV is performed at a slow scan rate (e.g., 0.1 mV/s) within a specific voltage window (e.g., 1.0-3.0 V for K-S, 1.7-2.8 V for Li-S) to identify the redox reactions.
- Galvanostatic Cycling: The cells are charged and discharged at various C-rates (a measure of the rate at which a battery is discharged relative to its maximum capacity) within the same voltage window to evaluate specific capacity, coulombic efficiency, and cycle life.
- Electrochemical Impedance Spectroscopy (EIS): EIS is conducted at different states of charge to analyze the internal resistance and charge transfer kinetics of the battery.

Mandatory Visualizations

Charge-Discharge Mechanisms and the Polysulfide Shuttle Effect

The following diagram illustrates the fundamental differences in the charge-discharge mechanisms and the notorious polysulfide shuttle effect between K-S and Li-S batteries. In both systems, the sulfur cathode undergoes a series of reduction steps upon discharge, forming soluble long-chain polysulfides that can diffuse to the metal anode, leading to capacity loss.

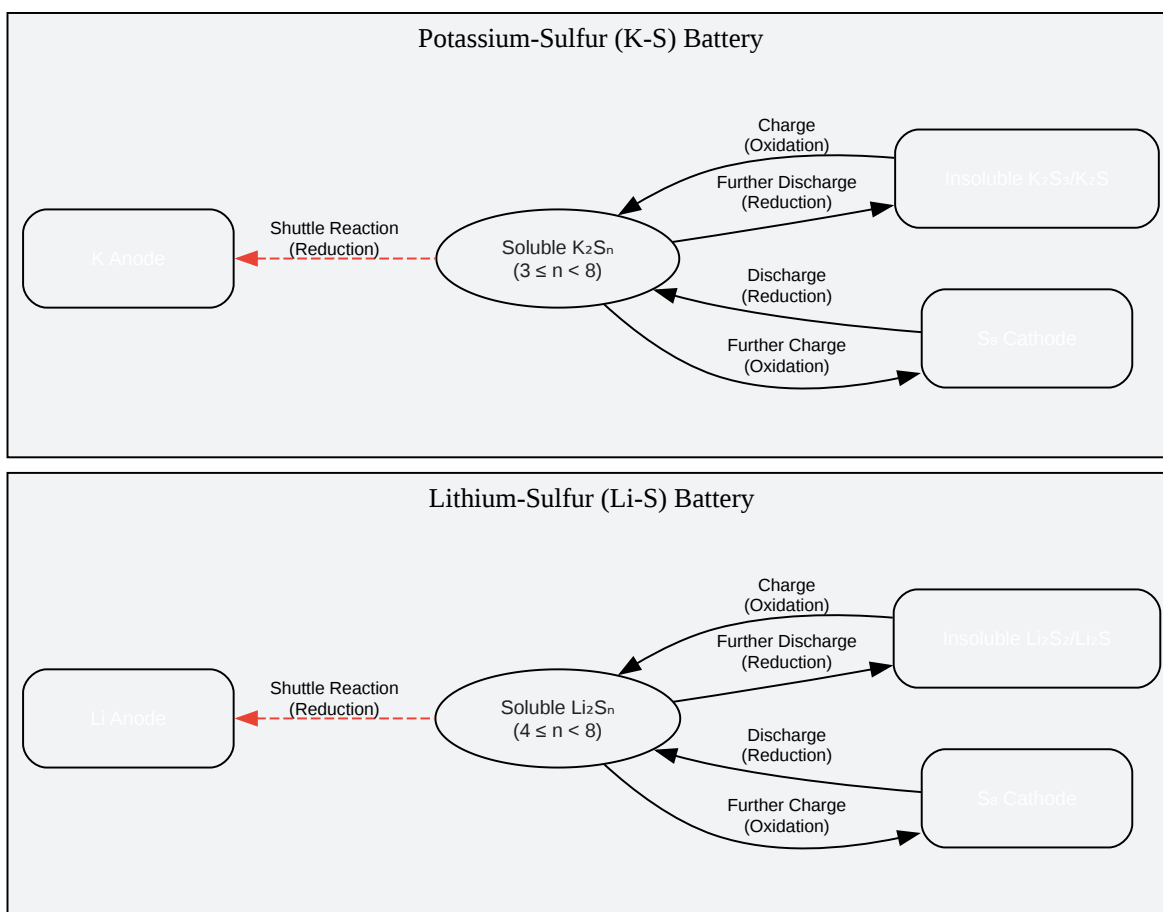

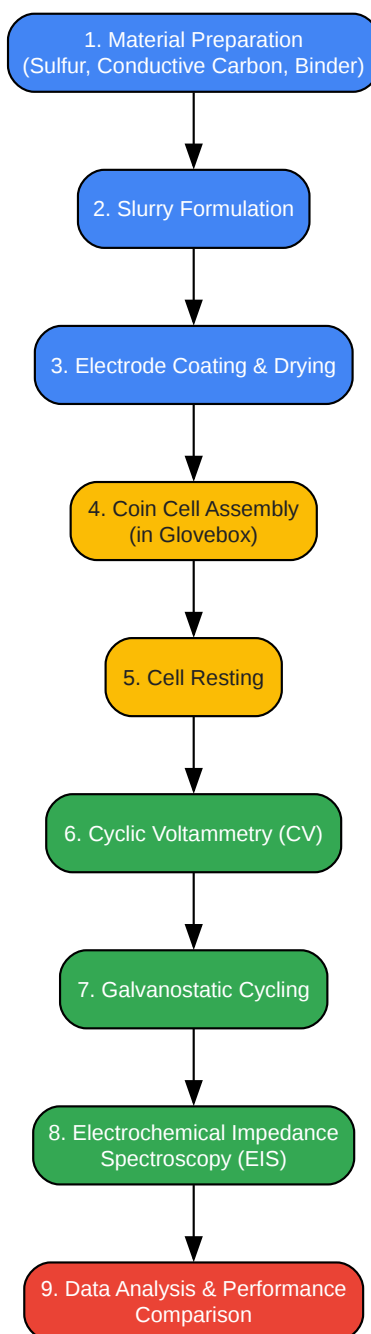

[Click to download full resolution via product page](#)

Need Custom Synthesis?

BenchChem offers custom synthesis for rare earth carbides and specific isotopic labeling.

Email: info@benchchem.com or [Request Quote Online](#).

References

- 1. mdpi.com [mdpi.com]
- 2. ViPER - Research [engineering.purdue.edu]
- 3. espec.com [espec.com]
- 4. Performance benchmarking and analysis of lithium-sulfur batteries for next-generation cell design - PMC [pmc.ncbi.nlm.nih.gov]
- 5. energy.gov [energy.gov]
- 6. researchgate.net [researchgate.net]
- 7. What are the Top 6 Standards for Lithium Battery Safety Testing? – Kelviron Blog [kelviron.in]
- 8. researchgate.net [researchgate.net]
- 9. researchgate.net [researchgate.net]
- To cite this document: BenchChem. [K-S vs. Li-S Batteries: A Comparative Guide to Electrochemical Performance]. BenchChem, [2025]. [Online PDF]. Available at: [https://www.benchchem.com/product/b1232493#electrochemical-performance-comparison-of-k-s-vs-li-s-batteries]

Disclaimer & Data Validity:

The information provided in this document is for Research Use Only (RUO) and is strictly not intended for diagnostic or therapeutic procedures. While BenchChem strives to provide accurate protocols, we make no warranties, express or implied, regarding the fitness of this product for every specific experimental setup.

Technical Support: The protocols provided are for reference purposes. Unsure if this reagent suits your experiment? [[Contact our Ph.D. Support Team for a compatibility check](#)]

Need Industrial/Bulk Grade? [Request Custom Synthesis Quote](#)

BenchChem

Our mission is to be the trusted global source of essential and advanced chemicals, empowering scientists and researchers to drive progress in science and industry.

Contact

Address: 3281 E Guasti Rd

Ontario, CA 91761, United States

Phone: (601) 213-4426

Email: info@benchchem.com