

# Application Notes and Protocols for Studying BrO + ClO Reaction Kinetics

**Author:** BenchChem Technical Support Team. **Date:** April 2026

## Compound of Interest

Compound Name: Bromine oxide

Cat. No.: B1232602

[Get Quote](#)

Audience: Researchers, scientists, and drug development professionals.

Introduction: The reaction between bromine monoxide (BrO) and chlorine monoxide (ClO) is a key process in stratospheric chemistry, playing a significant role in ozone depletion cycles. Understanding the kinetics of this reaction is crucial for accurate atmospheric modeling. This document provides detailed application notes and protocols for the experimental study of BrO + ClO reaction kinetics, primarily focusing on two common techniques: discharge-flow mass spectrometry and laser flash photolysis with UV absorption spectroscopy.

## I. Experimental Methodologies

Two primary experimental techniques are widely employed to investigate the kinetics of the BrO + ClO reaction:

- Discharge-Flow Mass Spectrometry (DF-MS): This technique allows for the study of gas-phase reactions at low pressures and over a range of temperatures.<sup>[1][2]</sup> Radicals are generated in a flow tube, and their concentrations, along with those of the products, are monitored using mass spectrometry.

- Laser Flash Photolysis with UV Absorption Spectroscopy (LFP-UVAS): This method is used to study fast gas-phase reactions.<sup>[3][4]</sup> A laser pulse initiates the reaction by photolyzing precursor molecules to generate the radicals of interest. The concentrations of reactants and products are then monitored in real-time by their characteristic UV absorption spectra.<sup>[3][4]</sup>

## II. Experimental Protocols

This protocol is based on the methodology described by Friedl and Sander.<sup>[1]</sup>

### 1. Reactant Generation:

- BrO radicals are typically produced by the reaction of Br atoms with ozone ( $O_3$ ). Bromine atoms are generated by passing a mixture of  $Br_2$  in a carrier gas (e.g., He) through a microwave discharge.
- ClO radicals are generated by the reaction of Cl atoms with  $O_3$  or  $Cl_2O$ .<sup>[5]</sup> Chlorine atoms are produced by a microwave discharge of  $Cl_2$  in a carrier gas.
- Ozone ( $O_3$ ) is generated by flowing oxygen gas through a cell containing a mercury "pen-ray" lamp.<sup>[4]</sup>

### 2. Reaction Conditions:

- The reaction is carried out in a temperature-controlled flow tube.
- The pressure is typically maintained at around 1 Torr.<sup>[1]</sup>
- The temperature can be varied over a range, for example, from 220 K to 400 K, to study the temperature dependence of the reaction.<sup>[1]</sup>

### 3. Detection:

- A mass spectrometer is used to detect the concentrations of reactants (BrO, ClO) and products (e.g., OClO, BrCl) as a function of reaction time.

### 4. Data Analysis:

- The rate coefficient for the overall reaction and for individual product channels is determined by monitoring the decay of reactants and the formation of products.

This protocol is based on the methodology described by Ferracci and Rowley.[\[3\]](#)[\[4\]](#)

#### 1. Precursor Mixture Preparation:

- A gas mixture containing precursors for BrO and ClO radicals is prepared. A typical mixture includes Cl<sub>2</sub>, Cl<sub>2</sub>O, Br<sub>2</sub>, O<sub>3</sub>, O<sub>2</sub>, and a balance of N<sub>2</sub>.[\[4\]](#)
- Typical precursor concentrations are in the range of 10<sup>15</sup> to 10<sup>18</sup> molecules cm<sup>-3</sup>.[\[4\]](#)

#### 2. Radical Generation:

- A laser flash (e.g., from an excimer laser) is used to photolyze the precursor molecules (e.g., Cl<sub>2</sub>O or O<sub>3</sub>) to produce the desired radicals.

#### 3. Detection:

- Time-resolved UV absorption spectroscopy is used to monitor the concentrations of BrO, ClO, and the product OCIO simultaneously.[\[3\]](#)[\[4\]](#)
- A charge-coupled device (CCD) detector allows for broadband spectral acquisition.[\[3\]](#)[\[4\]](#)

#### 4. Data Analysis:

- The total rate coefficient and the branching ratio for the OCIO-producing channel are determined by fitting the time-resolved absorption data to a kinetic model.[\[3\]](#)[\[4\]](#)

### III. Quantitative Data

The BrO + ClO reaction proceeds through multiple product channels:

- BrO + ClO → Br + ClOO (Channel 1a)
- BrO + ClO → Br + OCIO (Channel 1b)
- BrO + ClO → BrCl + O<sub>2</sub> (Channel 1c)[\[1\]](#)

The overall rate constant and the branching ratios for these channels are temperature-dependent.

Table 1: Summary of Rate Coefficients for the BrO + ClO Reaction

Study	Experimental Technique	Temperature (K)	Total Rate Coefficient (k <sub>total</sub> ) (cm <sup>3</sup> molecule <sup>-1</sup> s <sup>-1</sup> )	Reference
Friedl and Sander (1989)	DF-MS	220 - 400	$(2.59 \pm 0.36) \times 10^{-12} \exp((445 \pm 84)/T)$	[2]
Hills et al. (1988)	LFP-UVAS	241 - 408	$(8.2 \pm 1.0) \times 10^{-12}$ (temperature independent)	[6]
Ferracci and Rowley (2013)	LFP-UVAS	246 - 314	$(2.5 \pm 2.2) \times 10^{-12} \exp((630 \pm 240)/T)$	[3][4]

Table 2: Temperature Dependence of Branching Ratios for the BrO + ClO Reaction

Study	Temperature (K)	Branching Ratio ( $\alpha$ ) for Br + ClOO ( $k_{1a}/k_{total}$ )	Branching Ratio ( $\beta$ ) for Br + OCIO ( $k_{1\beta}/k_{total}$ )	Branching Ratio ( $\gamma$ ) for BrCl + O <sub>2</sub> ( $k_{1c}/k_{total}$ )	Reference
Friedl and Sander (1989)	220	0.06	-	Dominant channel	[4]
Friedl and Sander (1989)	400	0.08	-	-	[4]
Hills et al. (1988)	241 - 408	-	$0.55 \pm 0.10$	$< 0.02$	[6]
Poulet et al. (1990)	298	-	-	0.12	[4]

## IV. Visualizations

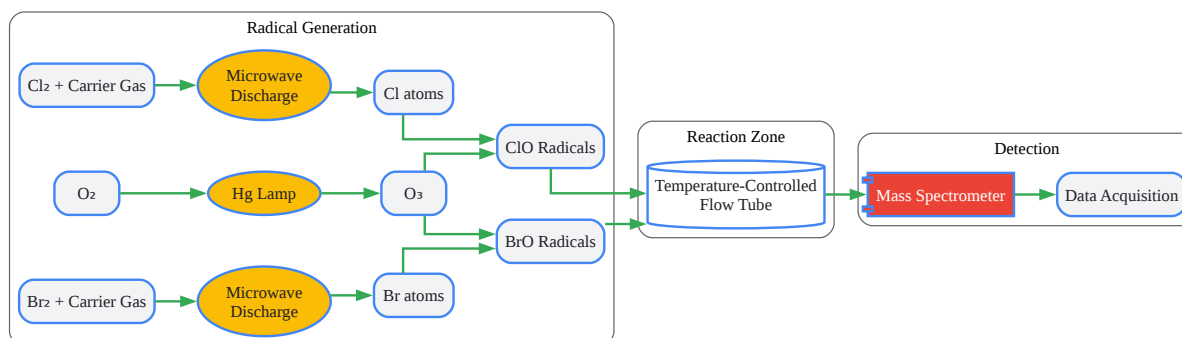

[Click to download full resolution via product page](#)

Caption: Workflow for Discharge-Flow Mass Spectrometry.

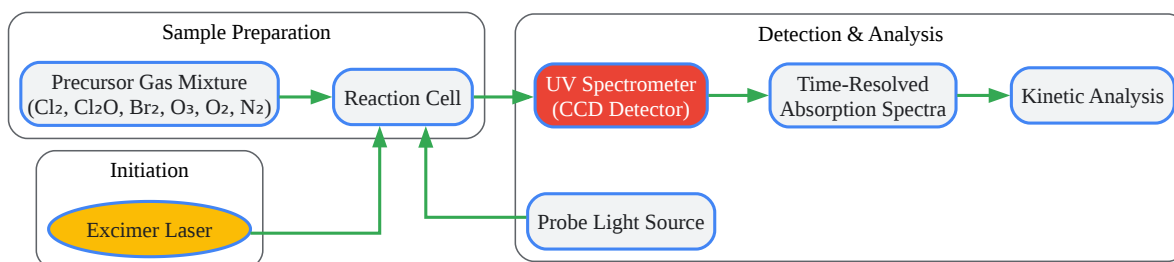

[Click to download full resolution via product page](#)

Caption: Workflow for Laser Flash Photolysis UV Absorption.

### Need Custom Synthesis?

BenchChem offers custom synthesis for rare earth carbides and specific isotopic labeling.

Email: [info@benchchem.com](mailto:info@benchchem.com) or [Request Quote Online](#).

## References

- 1. [ntrs.nasa.gov](https://ntrs.nasa.gov) [[ntrs.nasa.gov](https://ntrs.nasa.gov)]
- 2. Kinetics and temperature dependence of the BrO + ClO reaction (Journal Article) | [OSTI.GOV](https://www.osti.gov) [[osti.gov](https://www.osti.gov)]
- 3. Kinetic studies of the BrO + ClO cross-reaction over the range T = 246–314 K - Physical Chemistry Chemical Physics (RSC Publishing) [[pubs.rsc.org](https://pubs.rsc.org)]
- 4. Kinetic studies of the BrO + ClO cross-reaction over the range T = 246–314 K - Physical Chemistry Chemical Physics (RSC Publishing) DOI:10.1039/C3CP53440E [[pubs.rsc.org](https://pubs.rsc.org)]
- 5. Temperature dependence of the HO2 + ClO reaction. 2. Reaction kinetics using the discharge-flow resonance-fluorescence technique - PubMed [[pubmed.ncbi.nlm.nih.gov](https://pubmed.ncbi.nlm.nih.gov)]

- 6. Temperature dependence of the rate constant and product channels for the BrO + ClO reaction (Journal Article) | OSTI.GOV [osti.gov]
- To cite this document: BenchChem. [Application Notes and Protocols for Studying BrO + ClO Reaction Kinetics]. BenchChem, [2026]. [Online PDF]. Available at: [https://www.benchchem.com/product/b1232602/docs#application-notes-and-protocols-for-studying-bro-clo-reaction-kinetics]

---

**Disclaimer & Data Validity:**

The information provided in this document is for Research Use Only (RUO) and is strictly not intended for diagnostic or therapeutic procedures. While BenchChem strives to provide accurate protocols, we make no warranties, express or implied, regarding the fitness of this product for every specific experimental setup.

**Technical Support:** The protocols provided are for reference purposes. Unsure if this reagent suits your experiment?

**Need Industrial/Bulk Grade?** [Request Custom Synthesis Quote](#)

## BenchChem

Our mission is to be the trusted global source of essential and advanced chemicals, empowering scientists and researchers to drive progress in science and industry.

### Contact

Address: 3281 E Guasti Rd  
Ontario, CA 91761, United States  
Phone: (601) 213-4426  
Email: [info@benchchem.com](mailto:info@benchchem.com)

[Contact our Ph.D. Support Team for a compatibility check](#)