

# A Comparative Guide to BrO Formation: Sea Salt Aerosols vs. Snowpack Sources

**Author:** BenchChem Technical Support Team. **Date:** April 2026

## Compound of Interest

Compound Name: Bromine oxide

Cat. No.: B1232602

[Get Quote](#)

For Researchers, Scientists, and Drug Development Professionals

This guide provides an objective comparison of Bromine monoxide (BrO) formation from two primary environmental sources: sea salt aerosols and snowpack. Understanding these pathways is crucial for atmospheric chemistry models and assessing the environmental fate of various compounds. This document synthesizes experimental data, details methodologies, and illustrates the core chemical processes involved.

## Introduction to Reactive Bromine and BrO Formation

Reactive bromine species, particularly the bromine radical (Br) and bromine monoxide (BrO), play a significant role in the troposphere. They are known to be powerful catalysts for ozone depletion, influence the oxidative capacity of the atmosphere, and are involved in the oxidation of gaseous elemental mercury.<sup>[1]</sup> The release of reactive bromine from saline surfaces, such as sea salt aerosols and snowpack, can lead to rapid, autocatalytic events known as "bromine explosions," where BrO concentrations can increase dramatically.<sup>[2][3]</sup> These events are most prominent in polar regions during springtime.<sup>[1][4]</sup>

## Chemical Pathways of BrO Formation

The fundamental mechanism for BrO formation from both sea salt aerosols and snowpack involves the oxidation of bromide ions ( $\text{Br}^-$ ) to produce photolabile bromine species (e.g.,  $\text{Br}_2$ ), which then photolyze to form bromine radicals. These radicals react with ozone to produce BrO, initiating a catalytic cycle. This process, often termed the "bromine explosion," is autocatalytic, meaning the products of the reaction cycle further promote the release of bromine.

### BrO Formation from Sea Salt Aerosols

The heterogeneous reactions on the surface of sea salt aerosols are a major abiotic source of reactive bromine in the atmosphere.[5][6] The process is initiated by the uptake of acidic gases, which lowers the pH of the aerosol and facilitates the oxidation of bromide. Recent research has also highlighted a novel mechanism involving the spontaneous activation of bromide by  $\text{O}_2$  and  $\text{H}_2\text{O}$  at the air-water interface, a process significantly enhanced by light and acidity.[5][6]

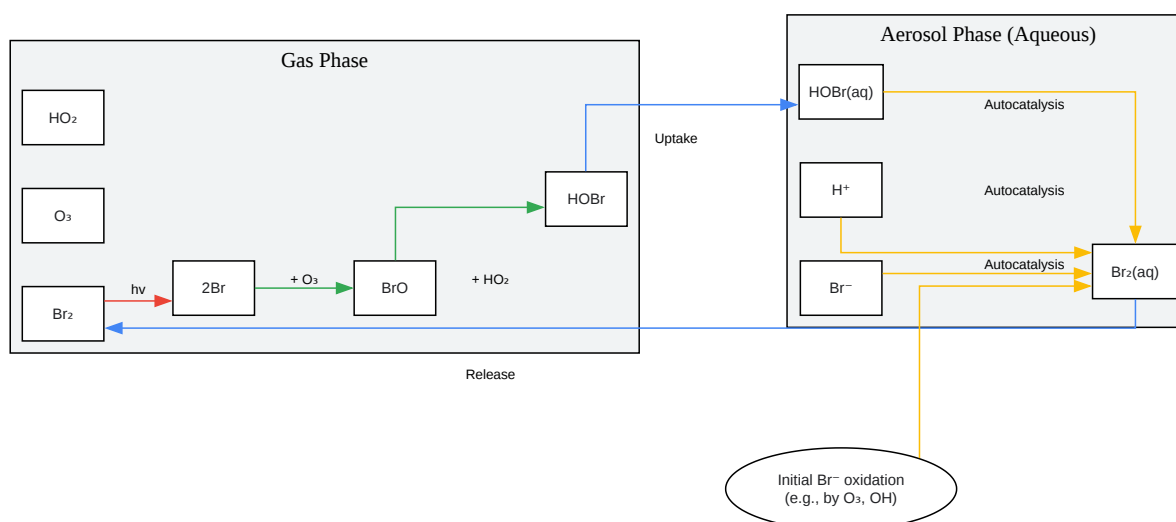

[Click to download full resolution via product page](#)

Caption: BrO formation pathway from sea salt aerosols.

## BrO Formation from Snowpack

BrO formation from snowpack shares a similar autocatalytic cycle but is initiated within the quasi-liquid layer on the surface of snow grains and in the interstitial air.[2] The process is highly dependent on the acidity and bromide-to-chloride ratio of the surface snow.[2]

Photochemical reactions within the snowpack produce oxidants that initiate the conversion of bromide to Br<sub>2</sub>. This Br<sub>2</sub> is then released into the atmosphere, where it triggers the bromine explosion cycle.

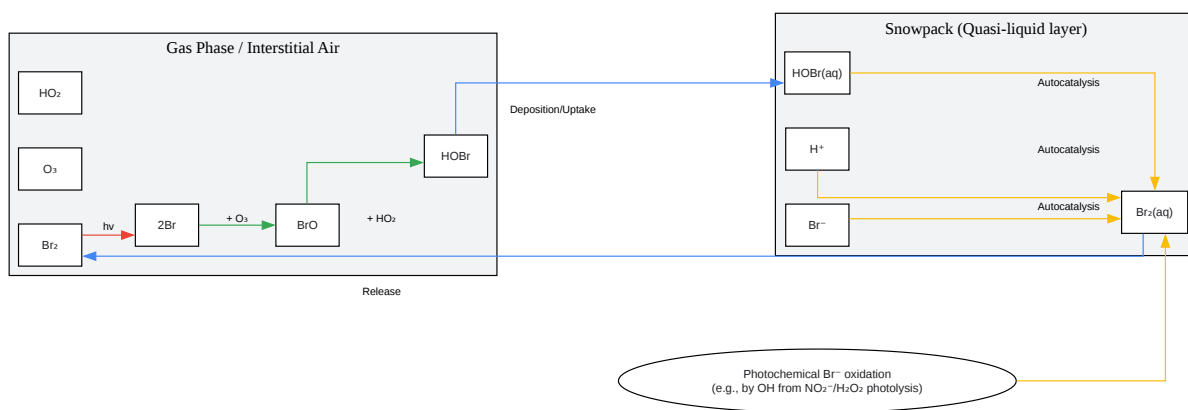

[Click to download full resolution via product page](#)

Caption: BrO formation pathway from snowpack sources.

## Experimental Protocols

### Sea Salt Aerosol BrO Formation Studies

A common experimental setup for studying BrO formation from sea salt aerosols involves a multiphase reaction chamber.

- **Aerosol Generation:** Sea salt aerosols are typically generated by bubbling a gas (e.g., purified air) through natural or artificial seawater, or by using a wave channel to simulate breaking waves.[1]
- **Reaction Chamber:** The generated aerosols are introduced into a reaction chamber, often a potential aerosol mass (PAM) or smog chamber, with controlled temperature, humidity, and UV irradiation (to simulate sunlight).
- **Reactant Introduction:** Oxidants such as ozone ( $O_3$ ) and other relevant trace gases are introduced into the chamber at controlled concentrations.
- **Instrumentation:** A suite of instruments is used to monitor the gas and particle phases. A chemical ionization mass spectrometer (CIMS) can be used to detect reactive bromine species like  $Br_2$ , BrO, and HOBr.[7] Aerosol size distribution and chemical composition are monitored using instruments like a scanning mobility particle sizer (SMPS) and an aerosol mass spectrometer (AMS).

### Snowpack BrO Formation Studies

Experiments investigating BrO formation from snowpack often utilize environmental chambers designed to hold snow samples.

- **Sample Collection:** Snow samples are collected from relevant environments (e.g., Arctic sea ice, tundra) and stored frozen until the experiment.
- **Environmental Chamber:** The snow sample is placed in a temperature-controlled chamber. The headspace above the snow is flushed with purified air containing controlled concentrations of reactants like ozone.[4]
- **Irradiation:** The snow surface is irradiated with lamps that simulate the solar spectrum.[4]

- Instrumentation: The composition of the headspace gas is continuously monitored. A CIMS is often used to measure the flux of Br<sub>2</sub> and other reactive bromine species from the snowpack. [7][8] Ion chromatography is used to determine the initial and final chemical composition of the snow, including bromide and chloride concentrations and pH.[4]

## Quantitative Data Comparison

The following tables summarize key quantitative parameters for BrO formation from sea salt aerosols and snowpack, compiled from various experimental studies. It is important to note that the data are from different studies with varying experimental conditions.

Table 1: Precursor Concentrations and Environmental Conditions

Parameter	Sea Salt Aerosols	Snowpack
Bromide (Br <sup>-</sup> ) Concentration	Varies with seawater composition; enrichment observed in smaller particles	Highly variable, 10 <sup>-2</sup> to 10 <sup>3</sup> μM in surface snow[9]
pH	Can become acidic (pH < 7) through uptake of atmospheric acids	Most efficient Br <sub>2</sub> production at pH 4.6–6.3[2]
Temperature	Ambient atmospheric temperatures	Typically sub-zero (°C) for polar regions
Br <sup>-</sup> /Cl <sup>-</sup> Molar Ratio	~1.5 x 10 <sup>-3</sup> in seawater	Higher ratios (1/148–1/38) favor efficient Br <sub>2</sub> production[2]

Table 2: BrO and Precursor Production/Concentration

Parameter	Sea Salt Aerosols	Snowpack
Br <sub>2</sub> Production/Emission Rate	Up to $1.55 \times 10^{10}$ molecules·cm <sup>-2</sup> ·s <sup>-1</sup> (under light and acidic conditions)[5][6]	$\sim 5 \times 10^8$ molecules·cm <sup>-2</sup> ·s <sup>-1</sup> (mean emission flux)[8]
BrO Mixing Ratios	Can contribute to atmospheric BrO levels exceeding 20 pptv[1]	Can lead to BrO mixing ratios of $\sim 15$ pptv[10]
HOBr Uptake Coefficient ( $\gamma$ )	$\gamma \approx 10^{-2}$ on frozen sea-salt surfaces[11]	Efficient uptake on acidic snow surfaces[2]

## Summary of Comparison

Feature	Sea Salt Aerosols	Snowpack
Primary Location	Marine boundary layer, widespread over oceans	Primarily polar regions, over sea ice and coastal tundra
Initiation Mechanism	Heterogeneous oxidation of Br <sup>-</sup> , often acid-catalyzed; spontaneous activation by O <sub>2</sub> /H <sub>2</sub> O.[5][6]	Photochemical production of oxidants within the snowpack initiates Br <sup>-</sup> oxidation.[2][4]
Key Influencing Factors	Acidity (pH), light, O <sub>3</sub> concentration.[5][6]	Light, snowpack acidity (pH), Br <sup>-</sup> /Cl <sup>-</sup> ratio, O <sub>3</sub> concentration.[2]
Physical State	Liquid or solid particles suspended in the atmosphere.	Solid ice matrix with a quasi-liquid layer at the surface.
Autocatalytic Cycle	Occurs in the aqueous phase of the aerosol.	Occurs in the quasi-liquid layer and interstitial air of the snowpack.[2]
Reported Production Rates	Potentially higher Br <sub>2</sub> production rates under optimal conditions.[5][6]	Significant source of reactive bromine, especially in polar spring.[2]

In conclusion, both sea salt aerosols and snowpack are significant sources of atmospheric BrO, driven by similar fundamental chemical principles of bromide oxidation and autocatalytic recycling. The primary differences lie in the initiation mechanisms, the physical environment of the reactions, and the specific environmental factors that control the rate of bromine release. While sea salt aerosols provide a widespread source of reactive bromine over the world's oceans, snowpack photochemistry is a dominant driver of the dramatic bromine explosion events observed in the polar regions.

### Need Custom Synthesis?

BenchChem offers custom synthesis for rare earth carbides and specific isotopic labeling.

Email: [info@benchchem.com](mailto:info@benchchem.com) or [Request Quote Online](#).

## References

- [1. pubs.acs.org \[pubs.acs.org\]](https://pubs.acs.org)
- [2. Modeling sea-salt aerosols in the atmosphere: 1. Model development | Scilit \[scilit.com\]](#)
- [3. Effect of sea salt aerosol on tropospheric bromine chemistry | NASA Airborne Science Program \[airbornescience.nasa.gov\]](#)
- [4. science.purdue.edu \[science.purdue.edu\]](https://science.purdue.edu)
- [5. online.ucpress.edu \[online.ucpress.edu\]](https://online.ucpress.edu)
- [6. Spontaneous Molecular Bromine Production in Sea-Salt Aerosols - Beijing Institute of Technology \[pure.bit.edu.cn\]](#)
- [7. pmel.noaa.gov \[pmel.noaa.gov\]](https://pmel.noaa.gov)
- [8. epic.awi.de \[epic.awi.de\]](https://epic.awi.de)
- [9. Sea Spray Aerosol: Where Marine Biology Meets Atmospheric Chemistry - PMC \[pmc.ncbi.nlm.nih.gov\]](#)
- [10. ACP - Observations and source investigations of the boundary layer bromine monoxide \(BrO\) in the Ny-Ålesund Arctic \[acp.copernicus.org\]](#)
- [11. ACP - Uptake and reaction of HOBr on frozen and dry NaCl/NaBr surfaces between 253 and 233 K \[acp.copernicus.org\]](#)
- To cite this document: BenchChem. [A Comparative Guide to BrO Formation: Sea Salt Aerosols vs. Snowpack Sources]. BenchChem, [2026]. [Online PDF]. Available at:

[<https://www.benchchem.com/product/b1232602/docs#a-comparative-guide-to-bro-formation-sea-salt-aerosols-vs-snowpack-sources>]

---

**Disclaimer & Data Validity:**

The information provided in this document is for Research Use Only (RUO) and is strictly not intended for diagnostic or therapeutic procedures. While BenchChem strives to provide accurate protocols, we make no warranties, express or implied, regarding the fitness of this product for every specific experimental setup.

**Technical Support:** The protocols provided are for reference purposes. Unsure if this reagent suits your experiment?

**Need Industrial/Bulk Grade?** [Request Custom Synthesis Quote](#)

## BenchChem

Our mission is to be the trusted global source of essential and advanced chemicals, empowering scientists and researchers to drive progress in science and industry.

### Contact

Address: 3281 E Guasti Rd  
Ontario, CA 91761, United States  
Phone: (601) 213-4426  
Email: [info@benchchem.com](mailto:info@benchchem.com)

[Contact our Ph.D. Support Team for a compatibility check](#)