

Application Notes and Protocols for Cell-Based Assays Using Ursolic Aldehyde

Author: BenchChem Technical Support Team. **Date:** April 2026

Compound of Interest

Compound Name: *Ursolic aldehyde*

Cat. No.: *B12313032*

[Get Quote](#)

For Researchers, Scientists, and Drug Development Professionals

Disclaimer: Important Information Regarding Ursolic Aldehyde Data

The following application notes and protocols are primarily based on data and studies conducted on Ursolic Acid due to the limited availability of specific research on **Ursolic Aldehyde**. **Ursolic Aldehyde** is a closely related pentacyclic triterpenoid, and while the provided information can serve as a valuable starting point, it is crucial to note that the difference in the functional group (aldehyde vs. carboxylic acid) may result in different biological activities. Therefore, all protocols and expected outcomes should be independently validated for **Ursolic Aldehyde**.

Introduction

Ursolic aldehyde is a pentacyclic triterpenoid compound.[1] Its close analogue, Ursolic Acid, has been extensively studied and shown to possess a wide range of pharmacological properties, including anti-inflammatory, antioxidant, and anticancer activities.[2][3][4] These effects are attributed to its ability to modulate key signaling pathways involved in cell

proliferation, apoptosis, and inflammation. This document provides detailed protocols for cell-based assays to investigate the potential biological effects of **Ursolic Aldehyde**, based on the known activities of Ursolic Acid.

Mechanism of Action: Key Signaling Pathways

Based on studies of the closely related Ursolic Acid, **Ursolic Aldehyde** may exert its effects by modulating several critical signaling pathways.

NF- κ B Signaling Pathway

The Nuclear Factor-kappa B (NF- κ B) pathway is a central regulator of inflammation, immune responses, and cell survival.[5][6] Ursolic Acid has been shown to inhibit the activation of NF- κ B induced by various stimuli.[7][8] This inhibition is thought to occur through the suppression of I κ B α kinase (IKK) and p65 phosphorylation, preventing the translocation of NF- κ B to the nucleus and the subsequent transcription of pro-inflammatory and pro-survival genes.[7]

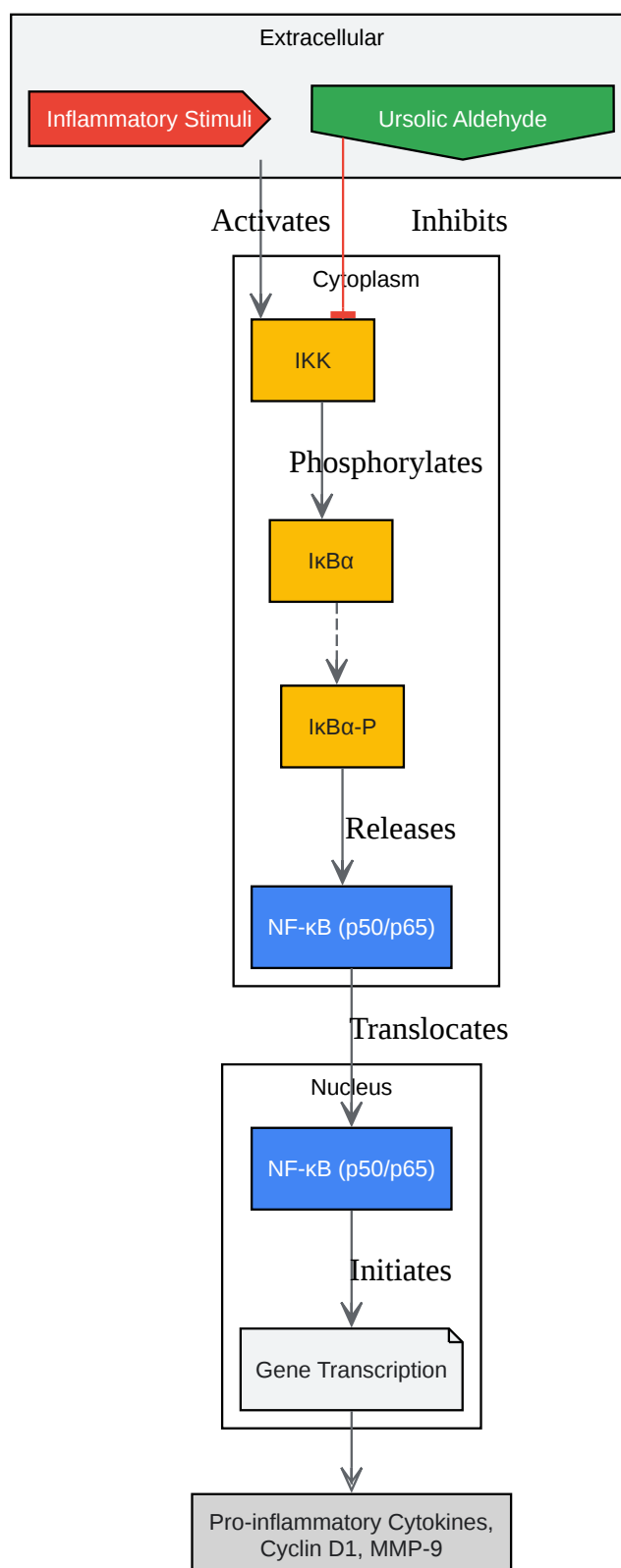

[Click to download full resolution via product page](#)

Caption: Proposed inhibition of the NF-κB signaling pathway by **Ursolic Aldehyde**.

STAT3 Signaling Pathway

Signal Transducer and Activator of Transcription 3 (STAT3) is a transcription factor that plays a crucial role in cell proliferation, survival, and differentiation. Constitutive activation of STAT3 is linked to various cancers.[9][10] Ursolic Acid has been shown to inhibit both constitutive and IL-6-inducible STAT3 activation.[10][11] This is achieved by inhibiting upstream kinases like JAK and Src, and by inducing the expression of the tyrosine phosphatase SHP-1.[10]

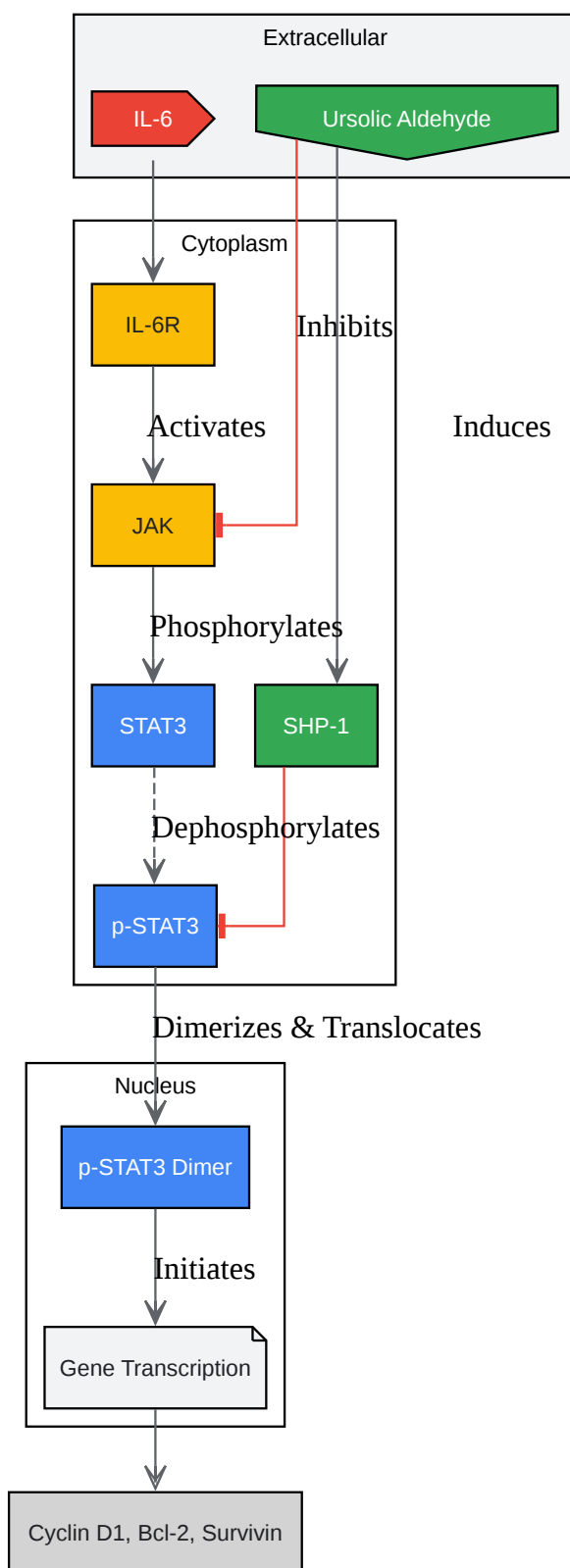

[Click to download full resolution via product page](#)

Caption: Proposed inhibition of the STAT3 signaling pathway by **Ursolic Aldehyde**.

Data Presentation: Quantitative Effects of Ursolic Acid

The following tables summarize the reported IC50 values of Ursolic Acid in various cancer cell lines. These values can serve as a reference for designing dose-response experiments for **Ursolic Aldehyde**.

Table 1: IC50 Values of Ursolic Acid in Different Cancer Cell Lines

Cell Line	Cancer Type	IC50 (μM)	Assay
NCI-H292	Lung Cancer	12	PI Staining
AsPC-1	Pancreatic Ductal Adenocarcinoma	10.1 - 14.2	MTT Assay
BxPC-3	Pancreatic Ductal Adenocarcinoma	10.1 - 14.2	MTT Assay
HTB-26	Breast Cancer	10 - 50	Crystal Violet Assay
PC-3	Pancreatic Cancer	10 - 50	Crystal Violet Assay
HepG2	Hepatocellular Carcinoma	10 - 50	Crystal Violet Assay
HeLa	Cervical Cancer	10	WST-1 Assay
HT-29	Colon Cancer	10	WST-1 Assay
MCF-7	Breast Cancer	20	WST-1 Assay

Data compiled from multiple sources.[\[12\]](#)[\[13\]](#)[\[14\]](#)[\[15\]](#)

Table 2: Anti-Inflammatory Effects of Ursolic Acid

Assay	Cell Line	Stimulant	Effect of Ursolic Acid
Nitric Oxide (NO) Production	RAW 264.7	LPS	Inhibition of NO production
IL-6, IL-8, TNF- α , IL-1 β Release	Various	LPS, Cytokine Mix	Reduction in cytokine levels

Data compiled from multiple sources.[\[3\]](#)[\[16\]](#)[\[17\]](#)

Experimental Protocols

General Experimental Workflow

The following diagram illustrates a general workflow for evaluating the bioactivity of **Ursolic Aldehyde** in cell-based assays.

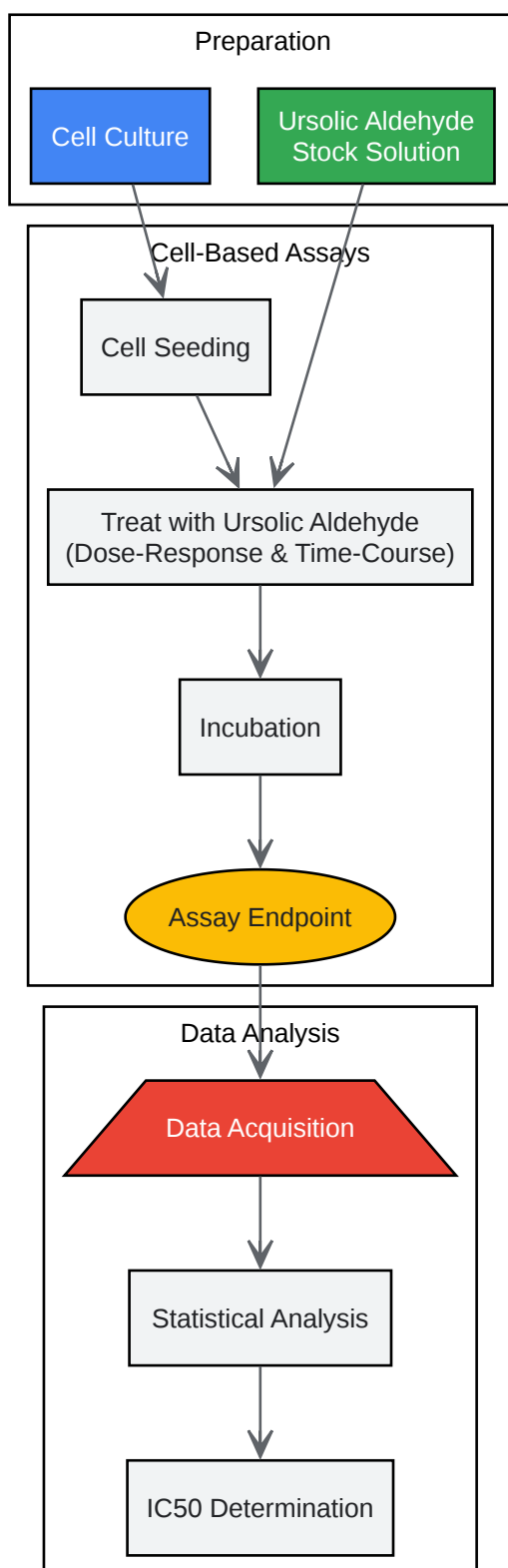

[Click to download full resolution via product page](#)

Caption: General workflow for cell-based assays with **Ursolic Aldehyde**.

Protocol 1: Cell Viability Assessment using MTT Assay

This protocol determines the effect of **Ursolic Aldehyde** on cell proliferation and viability.

Materials:

- Target cell line (e.g., HCT116, SW480, HeLa)
- Complete cell culture medium
- **Ursolic Aldehyde**
- DMSO (for stock solution)
- 96-well plates
- MTT (3-(4,5-dimethylthiazol-2-yl)-2,5-diphenyltetrazolium bromide) solution (5 mg/mL in PBS)
- Solubilization buffer (e.g., DMSO or 0.01 M HCl in 10% SDS)
- Microplate reader

Procedure:

- **Cell Seeding:** Seed cells in a 96-well plate at a density of 5,000-10,000 cells/well in 100 μ L of complete medium. Incubate for 24 hours at 37°C in a 5% CO₂ incubator.
- **Compound Preparation:** Prepare a stock solution of **Ursolic Aldehyde** in DMSO. Make serial dilutions in culture medium to achieve the desired final concentrations. The final DMSO concentration should not exceed 0.5%.
- **Treatment:** Remove the medium and add 100 μ L of medium containing various concentrations of **Ursolic Aldehyde** or vehicle control (medium with the same percentage of DMSO) to the wells.
- **Incubation:** Incubate the plate for 24, 48, or 72 hours at 37°C in a 5% CO₂ incubator.
- **MTT Addition:** Add 20 μ L of MTT solution to each well and incubate for 4 hours at 37°C.

- Solubilization: Remove the medium containing MTT and add 150 μ L of solubilization buffer to each well to dissolve the formazan crystals.
- Measurement: Read the absorbance at 570 nm using a microplate reader.
- Analysis: Calculate the percentage of cell viability relative to the vehicle control and determine the IC50 value.

Protocol 2: Apoptosis Detection using Annexin V-FITC/Propidium Iodide (PI) Staining

This protocol quantifies the induction of apoptosis by **Ursolic Aldehyde**.

Materials:

- Target cell line
- 6-well plates
- **Ursolic Aldehyde**
- Annexin V-FITC Apoptosis Detection Kit (containing Annexin V-FITC, Propidium Iodide, and Binding Buffer)
- Flow cytometer

Procedure:

- Cell Seeding and Treatment: Seed 1×10^5 cells/well in 6-well plates and allow them to attach overnight. Treat the cells with the desired concentrations of **Ursolic Aldehyde** for 24-48 hours.[12]
- Cell Harvesting: Collect both adherent and floating cells. Centrifuge at 300 x g for 5 minutes.
- Staining: Resuspend the cell pellet in 1X Binding Buffer. Add Annexin V-FITC and Propidium Iodide according to the manufacturer's instructions. Incubate in the dark at room temperature for 15 minutes.

- Flow Cytometry: Analyze the stained cells by flow cytometry within one hour.
- Analysis: Differentiate between viable (Annexin V-/PI-), early apoptotic (Annexin V+/PI-), late apoptotic (Annexin V+/PI+), and necrotic (Annexin V-/PI+) cells.

Protocol 3: Anti-Inflammatory Activity Assessment

This assay measures the inhibition of NO production, a key inflammatory mediator.

Materials:

- RAW 264.7 murine macrophage cell line
- Lipopolysaccharide (LPS)
- **Ursolic Aldehyde**
- Griess Reagent System
- 96-well plates
- Sodium Nitrite (for standard curve)

Procedure:

- Cell Seeding: Seed RAW 264.7 cells at 5×10^4 cells/well in a 96-well plate and incubate for 24 hours.[18]
- Pre-treatment: Pre-treat the cells with various concentrations of **Ursolic Aldehyde** for 1-2 hours.[18]
- Stimulation: Add LPS (final concentration 1 $\mu\text{g}/\text{mL}$) to induce NO production. Include a negative control (no LPS) and a positive control (LPS only).[18]
- Incubation: Incubate for 24 hours at 37°C.[18]
- Griess Assay: Transfer 100 μL of the supernatant to a new 96-well plate. Add 100 μL of Griess reagent and incubate for 10-15 minutes in the dark.[18]

- Measurement: Measure the absorbance at 540 nm.
- Analysis: Calculate the nitrite concentration from the standard curve and determine the percentage of NO inhibition.

This assay measures the effect of **Ursolic Aldehyde** on the release of pro-inflammatory cytokines like IL-6 and TNF- α .

Materials:

- Appropriate cell line (e.g., macrophages, stimulated T-cells)
- Inflammatory stimulant (e.g., LPS, Concanavalin A)
- **Ursolic Aldehyde**
- ELISA kits for the specific cytokines of interest (e.g., IL-6, TNF- α)

Procedure:

- Cell Seeding and Treatment: Seed cells and pre-treat with **Ursolic Aldehyde** as described in the NO inhibition assay.
- Stimulation: Add the appropriate stimulant to induce cytokine release.
- Incubation: Incubate for the recommended time for the specific cytokine (e.g., 6 hours for TNF- α , 24 hours for IL-6).^[17]
- Supernatant Collection: Collect the cell culture supernatant.
- ELISA: Perform the ELISA according to the manufacturer's protocol.
- Analysis: Quantify the cytokine concentration and determine the inhibitory effect of **Ursolic Aldehyde**.

Conclusion

While specific data for **Ursolic Aldehyde** is currently scarce, the extensive research on its close analogue, Ursolic Acid, provides a strong foundation for investigating its potential biological activities. The protocols and data presented here offer a comprehensive guide for researchers to design and execute cell-based assays to elucidate the mechanism of action of **Ursolic Aldehyde**. It is imperative to validate these methods and establish dose-response relationships specifically for **Ursolic Aldehyde** to accurately characterize its pharmacological profile.

Need Custom Synthesis?

BenchChem offers custom synthesis for rare earth carbides and specific isotopic labeling.

Email: info@benchchem.com or [Request Quote Online](#).

References

- [1. Ursolic aldehyde \[webbook.nist.gov\]](#)
- [2. mdpi.com \[mdpi.com\]](#)
- [3. Anti-inflammatory and antioxidant activity of ursolic acid: a systematic review and meta-analysis - PMC \[pmc.ncbi.nlm.nih.gov\]](#)
- [4. researchgate.net \[researchgate.net\]](#)
- [5. Ursolic acid inhibits NF- \$\kappa\$ B signaling and attenuates MMP-9/TIMP-1 in progressive osteoarthritis: a network pharmacology-based analysis - RSC Advances \(RSC Publishing\) \[pubs.rsc.org\]](#)
- [6. Ursolic acid inhibits NF- \$\kappa\$ B signaling and attenuates MMP-9/TIMP-1 in progressive osteoarthritis: a network pharmacology-based analysis - PMC \[pmc.ncbi.nlm.nih.gov\]](#)
- [7. Ursolic acid inhibits nuclear factor-kappaB activation induced by carcinogenic agents through suppression of I \$\kappa\$ B \$\alpha\$ kinase and p65 phosphorylation: correlation with down-regulation of cyclooxygenase 2, matrix metalloproteinase 9, and cyclin D1 - PubMed \[pubmed.ncbi.nlm.nih.gov\]](#)
- [8. Targeting Nrf2 and NF- \$\kappa\$ B Signaling Pathways in Cancer Prevention: The Role of Apple Phytochemicals \[mdpi.com\]](#)
- [9. Ursolic Acid Inhibits the Growth of Colon Cancer-initiating Cells by Targeting STAT3 | Anticancer Research \[ar.iiarjournals.org\]](#)

- 10. Ursolic acid inhibits STAT3 activation pathway leading to suppression of proliferation and chemosensitization of human multiple myeloma cells - PubMed [pubmed.ncbi.nlm.nih.gov]
- 11. Ursolic acid inhibits the growth of colon cancer-initiating cells by targeting STAT3 - PubMed [pubmed.ncbi.nlm.nih.gov]
- 12. Ursolic Acid Induces Apoptotic Cell Death Through AIF and Endo G Release Through a Mitochondria-dependent Pathway in NCI-H292 Human Lung Cancer Cells In Vitro - PMC [pmc.ncbi.nlm.nih.gov]
- 13. mdpi.com [mdpi.com]
- 14. researchgate.net [researchgate.net]
- 15. researchgate.net [researchgate.net]
- 16. Ursolic Acid Formulations Effectively Induce Apoptosis and Limit Inflammation in the Psoriasis Models In Vitro | MDPI [mdpi.com]
- 17. Potent Anti-Inflammatory Activity of Ursolic Acid, a Triterpenoid Antioxidant, Is Mediated through Suppression of NF- κ B, AP-1 and NF-AT - PMC [pmc.ncbi.nlm.nih.gov]
- 18. benchchem.com [benchchem.com]
- To cite this document: BenchChem. [Application Notes and Protocols for Cell-Based Assays Using Ursolic Aldehyde]. BenchChem, [2026]. [Online PDF]. Available at: [https://www.benchchem.com/product/b12313032/docs#application-notes-and-protocols-for-cell-based-assays-using-ursolic-aldehyde]

Disclaimer & Data Validity:

The information provided in this document is for Research Use Only (RUO) and is strictly not intended for diagnostic or therapeutic procedures. While BenchChem strives to provide accurate protocols, we make no warranties, express or implied, regarding the fitness of this product for every specific experimental setup.

Technical Support: The protocols provided are for reference purposes. Unsure if this reagent suits your experiment?

Need Industrial/Bulk Grade? [Request Custom Synthesis Quote](#)

BenchChem

Our mission is to be the trusted global source of essential and advanced chemicals, empowering scientists and researchers to drive progress in science and industry.

Contact

Address: 3281 E Guasti Rd

Ontario, CA 91761, United States

Phone: (601) 213-4426

Email: info@benchchem.com

[Contact our Ph.D. Support Team for a compatibility check](#)