

Technical Support Center: Calcium Alpha-Ketoglutarate (Ca-AKG) Animal Studies

Author: BenchChem Technical Support Team. **Date:** December 2025

Compound of Interest

Compound Name: Calcium oxoglurate

Cat. No.: B1231874

[Get Quote](#)

This guide is intended for researchers, scientists, and drug development professionals to address and manage the variability observed in animal responses to Calcium Alpha-Ketoglutarate (Ca-AKG) supplementation.

Frequently Asked Questions (FAQs)

Q1: What is Calcium Alpha-Ketoglutarate (Ca-AKG) and what is its primary mechanism of action?

A1: Calcium Alpha-Ketoglutarate (Ca-AKG) is a salt of alpha-ketoglutarate, a key intermediate in the Krebs (TCA) cycle, which is central to cellular energy production.^{[1][2]} Its primary mechanisms of action include:

- **Energy Metabolism:** As a crucial component of the Krebs cycle, it helps convert nutrients into ATP, the cell's primary energy currency.^[1] The calcium ions in Ca-AKG can allosterically activate enzymes in the TCA cycle, potentially boosting energy production.^[1]
- **Epigenetic Regulation:** AKG is an essential cofactor for enzymes like ten-eleven translocation (TET) dioxygenases and Jumonji C (JmjC) domain-containing histone demethylases. These enzymes are involved in DNA and histone demethylation, thereby influencing gene expression.
- **Nitrogen Metabolism:** AKG serves as a primary nitrogen acceptor, helping to remove ammonia and participating in the synthesis of amino acids like glutamate, glutamine, proline,

and arginine.

- **Signaling Molecule:** AKG can influence major cellular regulatory pathways, including mTOR and AMPK, which are master regulators of cell growth, metabolism, and aging.
- **Antioxidant Properties:** It acts as an antioxidant by neutralizing reactive oxygen species (ROS), reducing oxidative stress.

Q2: Why are we observing significant variability in our animal responses to Ca-AKG compared to published studies?

A2: Variability in animal responses to any supplement, including Ca-AKG, is common and can be attributed to a range of factors. Key contributors include:

- **Species and Strain:** Different animal species and even different strains within a species can metabolize and respond to compounds differently.
- **Age:** The effects of Ca-AKG can be age-dependent. Studies have shown that interventions in middle-aged or older animals can yield significant results, as endogenous AKG levels decline with age.
- **Sex:** Sexual dimorphism is a significant factor. For example, a key study on mice found that Ca-AKG had a more pronounced effect on the lifespan of females compared to males, although both sexes showed a reduction in frailty. Females also showed protection against age-related increases in inflammatory cytokines, an effect not seen in males.
- **Diet and Gut Microbiota:** The composition of the base diet can influence the absorption and efficacy of Ca-AKG. The gut microbiota also plays a role in metabolizing compounds and can vary between animals.
- **Dosage and Administration Route:** The concentration of Ca-AKG and the method of delivery (e.g., in feed, drinking water, oral gavage) will significantly impact bioavailability and physiological effects.
- **Experimental Conditions:** Factors like housing conditions, light cycles, and temperature can influence animal physiology and study outcomes.

Q3: What is the recommended dosage of Ca-AKG for mouse studies?

A3: The most frequently cited effective dose in mouse longevity and healthspan studies is a 2% (w/w) concentration of Ca-AKG mixed into the standard chow diet. This dosage has been shown to extend lifespan and reduce frailty in C57BL/6 mice when administered starting at 18 months of age. For administration in drinking water, concentrations have ranged from 2 mM to 50 mM in different studies. It is crucial to ensure the mixture is homogenous to provide consistent dosing.

Q4: Is there a difference between using Ca-AKG and other forms of AKG?

A4: Yes. Ca-AKG is a salt form that enhances the stability of AKG. The calcium component may also contribute to its effects, as calcium ions can activate key enzymes in the Krebs cycle. Other forms, like Arginine-AKG (AAKG) or Ornithine-AKG (OKG), are also available but may have different properties and effects. The selection of Ca-AKG in prominent aging studies was based on evidence from invertebrate models that showed lifespan extension.

Troubleshooting Guide

This section addresses specific issues that may arise during your experiments.

Issue / Observation	Potential Cause(s)	Recommended Action(s)
<p>No significant effect on lifespan or healthspan markers.</p>	<p>1. Insufficient Duration: The effects of Ca-AKG on aging are often observed over the long term. 2. Suboptimal Dosage: The dose may be too low for the specific animal model or strain. 3. Sex Differences: As noted, effects can be more significant in females. 4. Timing of Intervention: Starting the intervention too late or too early in the animal's life may alter the outcome. Key studies began at middle age (18 months for mice).</p>	<p>1. Ensure the study is sufficiently powered and runs long enough to observe age-related changes. 2. Refer to dose-response data from similar studies. Consider a pilot study with varying doses. The 2% w/w in feed is a well-documented starting point. 3. Analyze data for males and females separately. 4. Align the intervention start time with established protocols that have shown positive results.</p>
<p>Decreased food or water intake after supplementation.</p>	<p>1. Poor Palatability: The taste or texture of the supplemented feed/water may be aversive to the animals.</p>	<p>1. Gradual Introduction: Mix the Ca-AKG diet with the standard diet in increasing proportions (e.g., 25%, 50%, 75%, 100%) over several days to acclimate the animals. 2. Alternative Delivery: If aversion continues, consider another administration method, such as drinking water or oral gavage, though gavage can induce stress. 3. Monitor Intake: Regularly measure food and water consumption to ensure that changes in intake are not a confounding factor.</p>
<p>Inconsistent results between animals in the same group.</p>	<p>1. Inhomogeneous Mixture: The Ca-AKG may not be evenly distributed in the feed,</p>	<p>1. Ensure a thorough and validated mixing process for the diet. For large batches, use</p>

leading to variable dosing. 2. Biological Variability: Natural genetic and physiological differences exist even within the same strain of animals. 3. Social Stress: Housing conditions, such as cage dominance or fighting (especially among males), can impact physiology.

a mechanical mixer. Consider sending a sample for analytical testing to confirm concentration and homogeneity. 2. Increase the number of animals per group to improve statistical power and account for biological variance. 3. Monitor animal behavior. Isolate aggressive animals if necessary, as was done in key lifespan studies.

Concerns about Ca-AKG stability in solution.

1. Degradation: AKG solutions may degrade over time, especially when exposed to light and heat.

1. Fresh Preparation: Prepare fresh solutions every 2-3 days to ensure stability. 2. Proper Storage: Use opaque water bottles to protect the solution from light and store them in a cool, dark place.

Quantitative Data Summary

The following tables summarize key quantitative findings from a pivotal study by Asadi Shahmirzadi et al. (2020) on C57BL/6 mice with Ca-AKG supplementation starting at 18 months of age.

Table 1: Effects of Ca-AKG on Lifespan in C57BL/6 Mice

Sex	Cohort	Parameter	% Increase with Ca-AKG	Statistical Significance
Female	1	Median Lifespan	16.6%	Significant
90th Percentile Survival	19.7%	Significant		
2	Median Lifespan	10.5%	Significant	
90th Percentile Survival	8.0%	Significant		
Male	1	Median Lifespan	9.6%	Not Significant
2	Median Lifespan	12.8%	Not Significant	

Source: Data compiled from multiple reports on the same study.

Table 2: Effects of Ca-AKG on Healthspan (Frailty Index) in C57BL/6 Mice

Sex	Parameter	% Reduction with Ca-AKG
Female	Frailty Score	46%
Male	Frailty Score	41%

Source: Data compiled from multiple reports on the same study.

Experimental Protocols

Protocol 1: Dietary Supplementation of Ca-AKG in Mice

This protocol is based on the methodology used in successful mouse aging studies.

1. Materials:

- Standard rodent chow (e.g., Teklad 2918)
- High-purity Calcium Alpha-Ketoglutarate (Ca-AKG) powder
- Blender or food processor for grinding pellets
- Precision balance
- Mechanical mixer (for large batches) or large mixing bowl

2. Diet Preparation (for a 2% w/w concentration):

- Calculation: Determine the total amount of feed needed. To prepare 1 kg (1000 g) of supplemented feed, you will need 20 g of Ca-AKG and 980 g of standard chow.
- Grinding: Weigh the standard chow pellets and grind them into a fine, uniform powder. This is a critical step for ensuring even distribution.
- Mixing: Transfer the powdered chow to a large mixing bowl or mechanical mixer. Add the pre-weighed Ca-AKG powder. Mix thoroughly for at least 5-10 minutes to ensure a homogenous mixture.
- Storage: Store the control and experimental diets in airtight, labeled containers in a cool, dry place.

3. Animal Acclimation and Administration:

- Acclimation: For one week prior to the study, acclimate all animals to the powdered (non-supplemented) diet to get them used to the texture.
- Gradual Introduction (Optional but Recommended): To improve palatability, introduce the Ca-AKG diet by mixing it with the standard powdered diet in increasing ratios (25%, 50%, 75%, 100%) over 4 days.
- Administration: Provide the respective diets (control or 2% Ca-AKG) to the animals ad libitum. Ensure continuous access to fresh water.

4. Monitoring:

- Food Intake: Measure and record food consumption weekly per cage to monitor for any significant changes in intake.
- Health Status: Monitor animals daily for general health.
- Frailty Assessment: Conduct a frailty index assessment at regular intervals (e.g., monthly) as described in relevant literature.

Visualizations

Signaling Pathways and Experimental Workflows

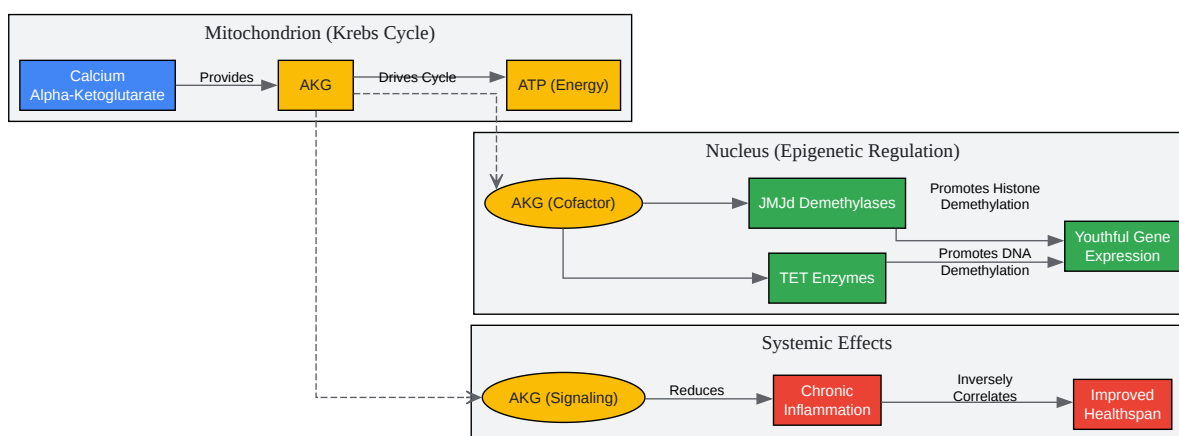

Figure 1: Key Mechanisms of Ca-AKG Action

[Click to download full resolution via product page](#)

Figure 1: Key Mechanisms of Ca-AKG Action

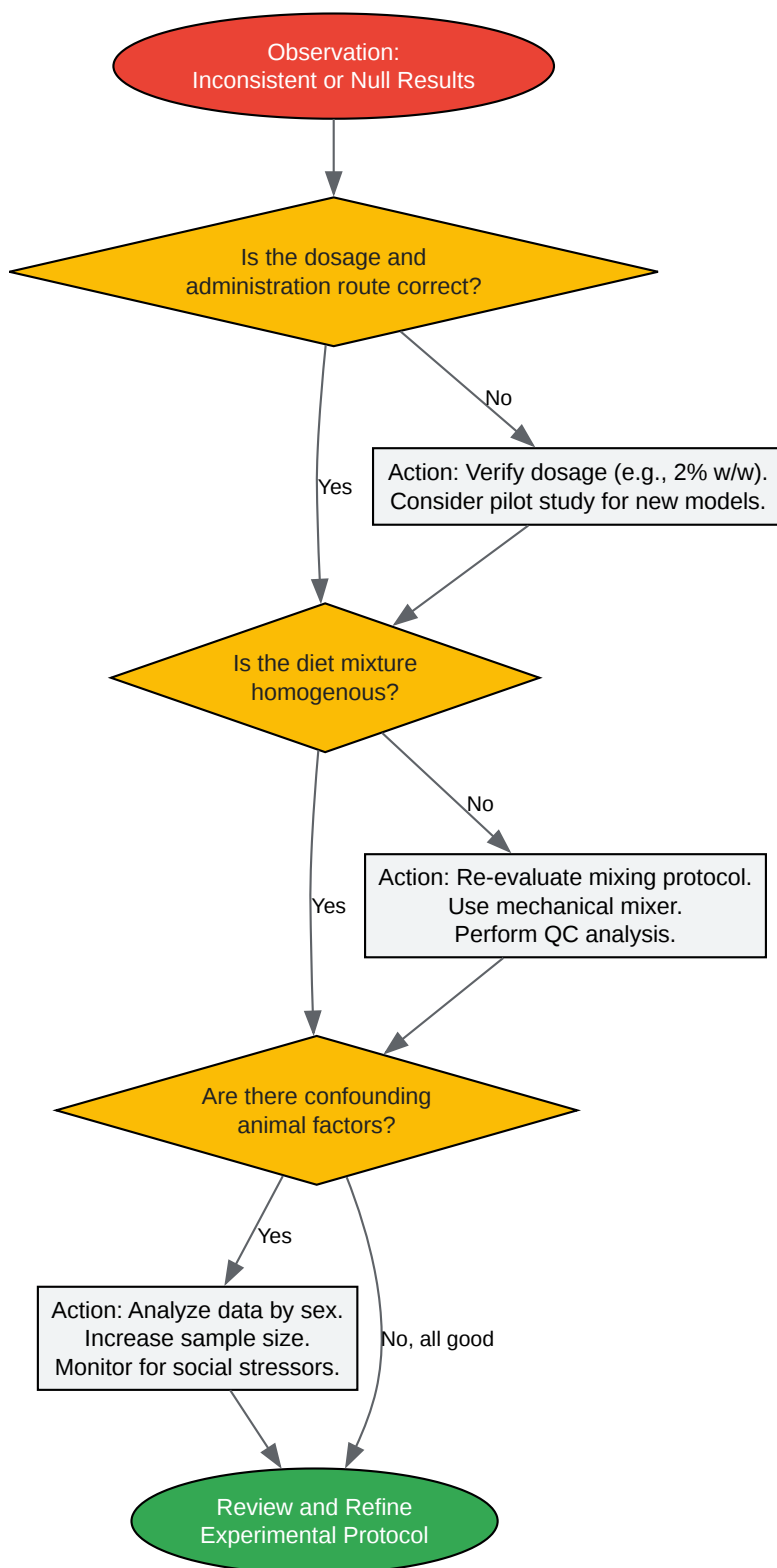

Figure 2: Troubleshooting Workflow for Inconsistent Results

[Click to download full resolution via product page](#)

Figure 2: Troubleshooting Workflow for Inconsistent Results

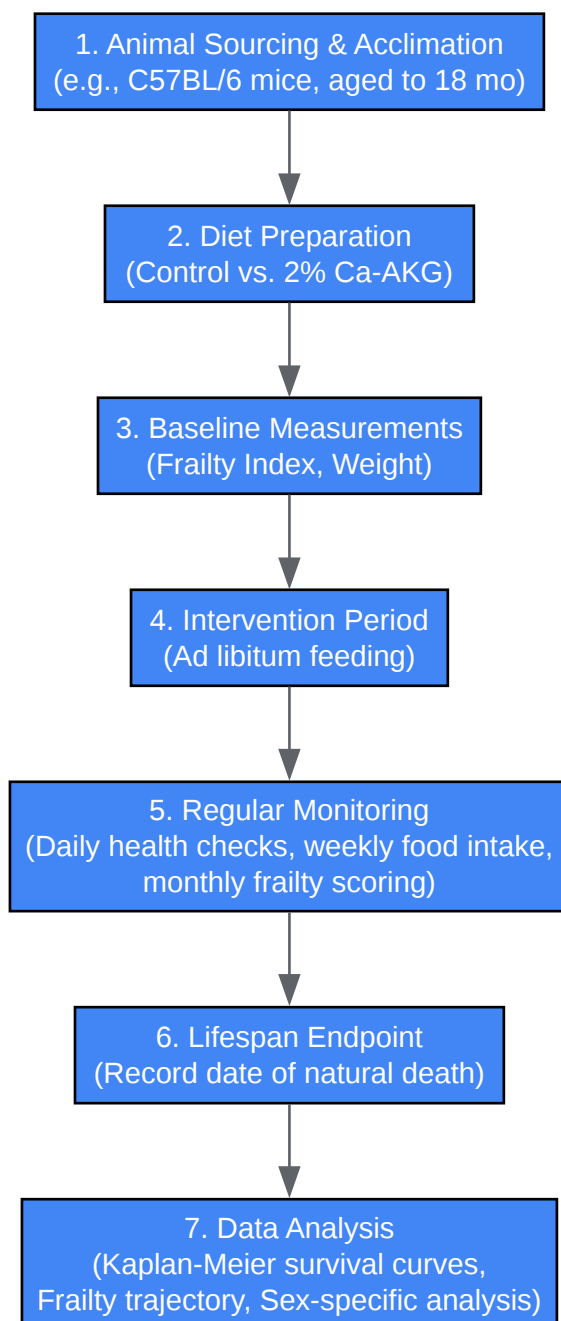

Figure 3: Standard Experimental Workflow for a Ca-AKG Mouse Study

[Click to download full resolution via product page](#)

Figure 3: Standard Experimental Workflow for a Ca-AKG Mouse Study

Need Custom Synthesis?

BenchChem offers custom synthesis for rare earth carbides and specific isotopic labeling.

Email: info@benchchem.com or [Request Quote Online](#).

References

- 1. benchchem.com [benchchem.com]
- 2. caringsunshine.com [caringsunshine.com]
- To cite this document: BenchChem. [Technical Support Center: Calcium Alpha-Ketoglutarate (Ca-AKG) Animal Studies]. BenchChem, [2025]. [Online PDF]. Available at: [https://www.benchchem.com/product/b1231874#addressing-variability-in-animal-responses-to-calcium-alpha-ketoglutarate]

Disclaimer & Data Validity:

The information provided in this document is for Research Use Only (RUO) and is strictly not intended for diagnostic or therapeutic procedures. While BenchChem strives to provide accurate protocols, we make no warranties, express or implied, regarding the fitness of this product for every specific experimental setup.

Technical Support: The protocols provided are for reference purposes. Unsure if this reagent suits your experiment? [[Contact our Ph.D. Support Team for a compatibility check](#)]

Need Industrial/Bulk Grade? [Request Custom Synthesis Quote](#)

BenchChem

Our mission is to be the trusted global source of essential and advanced chemicals, empowering scientists and researchers to drive progress in science and industry.

Contact

Address: 3281 E Guasti Rd
Ontario, CA 91761, United States
Phone: (601) 213-4426
Email: info@benchchem.com