

Confirming Cyclopamine-KAAD Target Engagement: A Comparative Technical Guide

Author: BenchChem Technical Support Team. **Date:** May 2026

Compound of Interest

Compound Name: Cyclopamine-KAAD

Cat. No.: B1231444

[Get Quote](#)

Executive Summary & Comparative Landscape[1]

Cyclopamine-KAAD (3-keto-N-aminoethylaminocaproyl dihydrocinnamoyl cyclopamine) is a high-potency synthetic derivative of the natural alkaloid Cyclopamine. While the parent compound (Cyclopamine) historically defined the inhibition of the Hedgehog (Hh) pathway transducer Smoothed (SMO), it suffers from poor solubility and moderate potency (~300 nM).

KAAD addresses these limitations with a nanomolar IC₅₀ (~10–20 nM) and improved aqueous solubility, making it the preferred in vitro tool compound for interrogating SMO blockade before advancing to clinical-grade inhibitors like Vismodegib.

Product Performance Matrix

The following table contrasts **Cyclopamine-KAAD** with its primary alternatives to justify experimental selection.

Feature	Cyclopamine-KAAD	Cyclopamine (Parent)	Vismodegib (Clinical)
Primary Target	Smoothened (SMO) Transmembrane Domain	Smoothened (SMO) Transmembrane Domain	Smoothened (SMO) Extracellular Loop/TMD
Potency (IC50)	High (10–20 nM)	Moderate (300–500 nM)	Very High (<10 nM)
Solubility	Improved (DMSO/Ethanol stable)	Poor (Acid unstable)	Optimized (Clinical formulation)
Mechanism	Direct Antagonist (Competes with BODIPY-Cyc)	Direct Antagonist	Allosteric/Orthosteric Antagonist
Primary Utility	In vitro mechanistic proof-of-concept	Historical reference	Clinical translation & resistant mutant studies

Mechanistic Logic: The Hedgehog Signaling Axis

To validate target engagement, one must understand the causality of the pathway. KAAD acts by binding the heptahelical bundle of SMO, preventing its accumulation in the primary cilium and blocking the downstream activation of GLI transcription factors.

Pathway Diagram (Inhibited State)

The following diagram illustrates the specific blockade point of **Cyclopamine-KAAD** within the Hh signaling cascade.

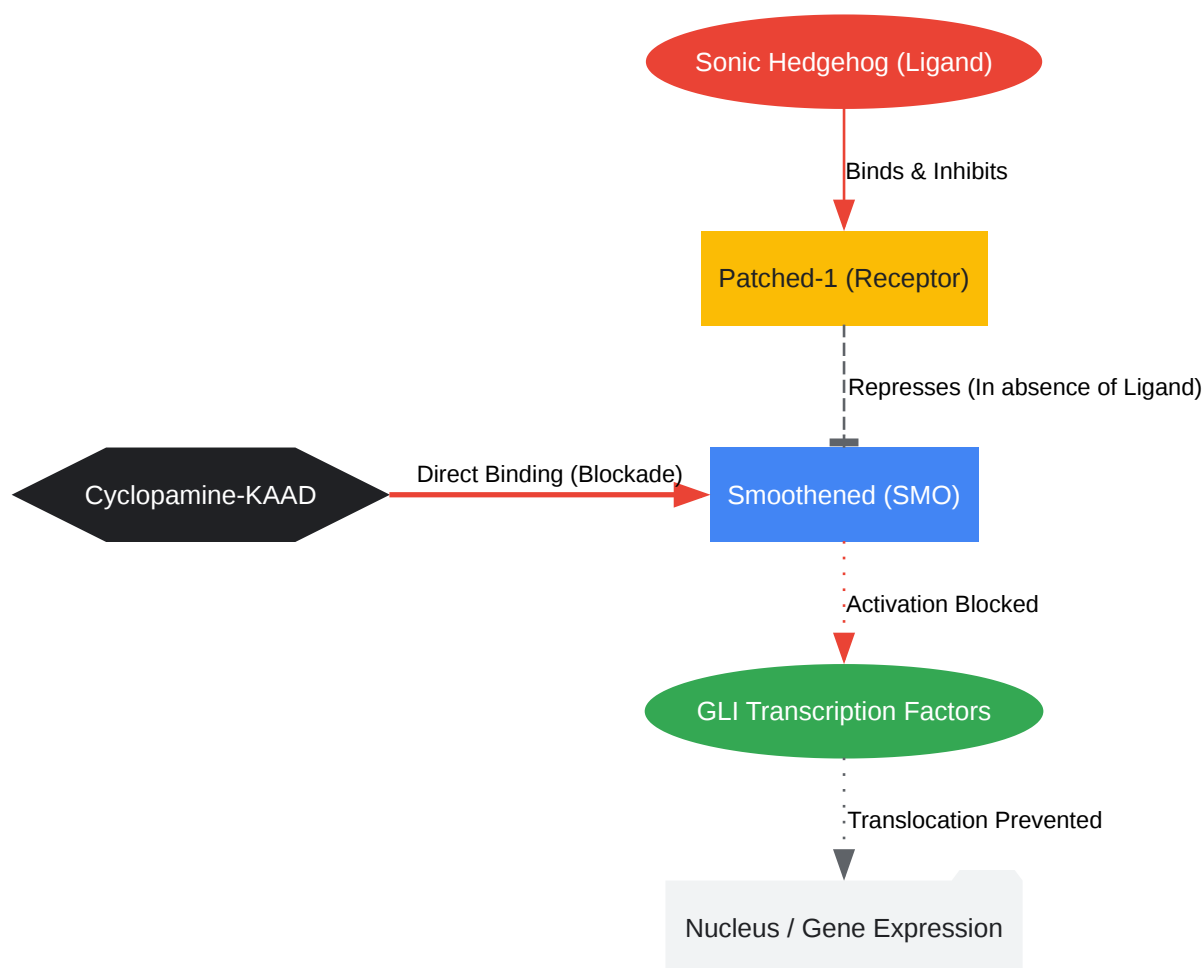

[Click to download full resolution via product page](#)

Caption: **Cyclopamine-KAAD** binds the SMO transmembrane domain, enforcing an inactive conformation and preventing GLI-mediated transcription.

Protocol 1: Direct Target Engagement (The "Gold Standard")

Method: BODIPY-Cyclopamine Competition Assay

Why this works: **Cyclopamine-KAAD** is non-fluorescent. To prove it physically binds SMO in cells (rather than just observing a downstream effect), you must set up a competition assay against a fluorescent tracer, BODIPY-Cyclopamine. If KAAD engages the target, it will displace the fluorescent probe, resulting in a loss of cellular fluorescence.

Experimental Workflow

- Cell Selection: Use SMO-overexpressing cells (e.g., HEK293T transfected with SMO-GFP) or cells with high endogenous SMO (e.g., NIH3T3 stimulated with Shh-conditioned medium).
- Tracer: BODIPY-Cyclopamine (typically used at ~5 nM).
- Competitor: **Cyclopamine-KAAD** (Titration: 1 nM to 1 μ M).

Step-by-Step Protocol

- Seeding: Plate cells at

cells/well in 12-well plates. Allow to adhere overnight.
- Transfection (Optional): If using HEK293, transiently transfect with a SMO expression vector (e.g., pGE-SMO) 24 hours prior to assay.
- Competition Incubation:
 - Prepare media containing 5 nM BODIPY-Cyclopamine (fixed concentration).
 - Add **Cyclopamine-KAAD** at increasing concentrations (e.g., 0, 1, 10, 100, 1000 nM).
 - Control: Include a sample with 5 μ M unlabeled Cyclopamine or Vismodegib to define non-specific binding background.
 - Incubate for 45 minutes at 37°C. (Note: Short incubation prevents internalization artifacts).
- Washing: Rapidly wash cells

with ice-cold PBS to remove unbound tracer.
- Analysis (Flow Cytometry):
 - Lift cells (Trypsin-free dissociation recommended to preserve surface proteins).
 - Analyze on a Flow Cytometer (Ex/Em: 488/510 nm for BODIPY).

- Gating: Gate on live cells.[1] If using SMO-GFP, gate on GFP+ population to ensure you are analyzing transfected cells.

Data Interpretation & Self-Validation

- Success Criteria: You should observe a dose-dependent decrease in Mean Fluorescence Intensity (MFI) in the BODIPY channel.
- IC50 Calculation: Plot % Bound (MFI) vs. Log[KAAD]. The IC50 for displacement should be in the low nanomolar range (~10–50 nM).
- Troubleshooting: If no displacement occurs, ensure the BODIPY-Cycloamine concentration is below the

of the tracer (approx 5-10 nM) to allow competition.

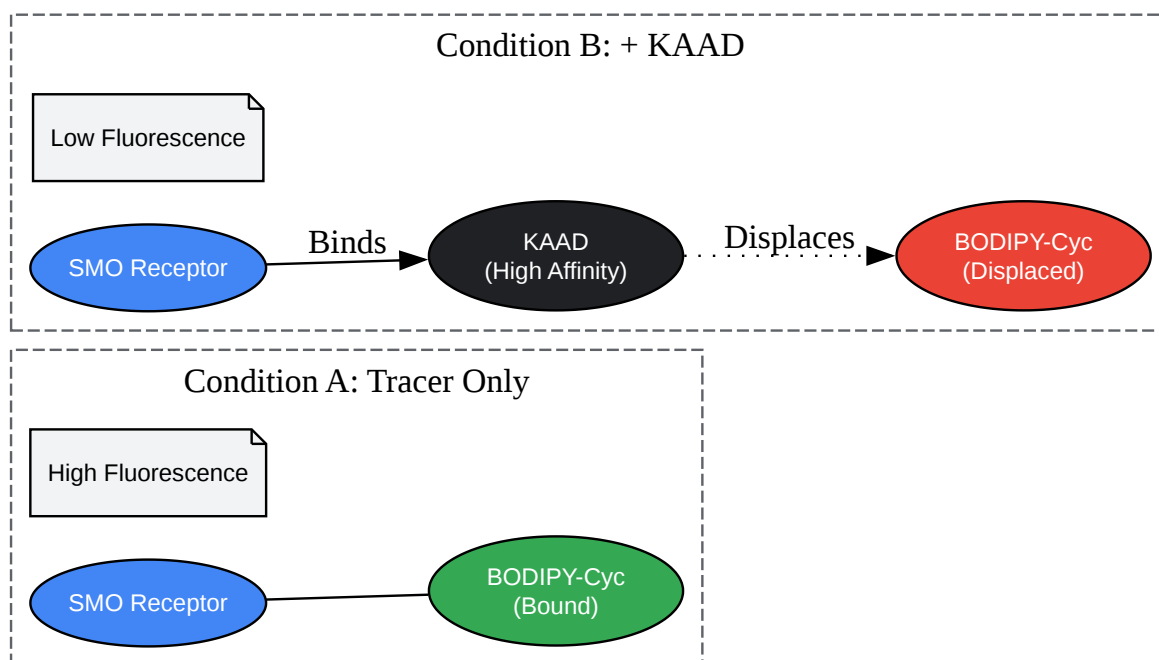

[Click to download full resolution via product page](#)

Caption: Schematic of the competition assay. KAAD displaces the fluorescent tracer, reducing the signal.

Protocol 2: Functional Validation (Downstream)

Method: GLI-Luciferase Reporter Assay (Shh-LIGHT2 Cells)

Why this works: While binding proves physical interaction, it does not prove inhibition. This assay confirms that KAAD binding functionally shuts down the transcriptional machinery.

Step-by-Step Protocol

- Cell System: Use Shh-LIGHT2 cells (NIH3T3 stably transfected with Gli-responsive Firefly luciferase and constitutive Renilla luciferase).
- Induction: Treat cells with Recombinant Sonic Hedgehog (Shh) protein (e.g., 100 ng/mL) or SAG (Smoothed Agonist, 100 nM) to activate the pathway.
- Treatment: Concurrently treat with **Cyclopamine-KAAD** (0.1 nM – 1 μ M).
- Incubation: Incubate for 24–30 hours. (Transcriptional changes take time).
- Lysis & Detection: Use a Dual-Luciferase assay system.
 - Measure Firefly (GLI signal).
 - Measure Renilla (Normalization for cell viability/number).
- Calculation: Calculate the Ratio (Firefly/Renilla). Normalize to "Shh-only" control (100% activity) and "Vehicle" control (0% activity).

Expected Results

- **Cyclopamine-KAAD**: Should show complete inhibition with an IC50
10–20 nM.
- Cyclopamine (Parent): IC50
300 nM.

- Conclusion: The left-shift in the dose-response curve for KAAD validates its superior potency.

References

- Chen, J. K., Taipale, J., Cooper, M. K., & Beachy, P. A. (2002). Inhibition of Hedgehog signaling by direct binding of cyclopamine to Smoothed.[2] *Genes & Development*, 16(21), 2743–2748.
- Taipale, J., et al. (2000). Effects of oncogenic mutations in Smoothed and Patched can be reversed by cyclopamine.
- Kozielowicz, P., et al. (2020). A NanoBRET-Based Binding Assay for Smoothed Allows Real-time Analysis of Ligand Binding and Distinction of Two Binding Sites for BODIPY-cyclopamine.[1][3] *Molecular Pharmacology*, 97(1), 23-34.[3]
- Lipinski, R. J., et al. (2008). Genome-wide analysis reveals mechanisms modulating sensitivity to the hedgehog pathway inhibitor cyclopamine. *BMC Genomics*, 9, 282.

Need Custom Synthesis?

BenchChem offers custom synthesis for rare earth carbides and specific isotopic labeling.

Email: info@benchchem.com or [Request Quote Online](#).

Sources

- 1. A NanoBRET-Based Binding Assay for Smoothed Allows Real-time Analysis of Ligand Binding and Distinction of Two Binding Sites for BODIPY-cyclopamine - PubMed [pubmed.ncbi.nlm.nih.gov]
- 2. Inhibition of Hedgehog signaling by direct binding of cyclopamine to Smoothed - PubMed [pubmed.ncbi.nlm.nih.gov]
- 3. Inhibition of Hedgehog signaling by direct binding of cyclopamine to Smoothed [genesdev.cshlp.org]
- To cite this document: BenchChem. [Confirming Cyclopamine-KAAD Target Engagement: A Comparative Technical Guide]. BenchChem, [2026]. [Online PDF]. Available at:

[<https://www.benchchem.com/product/b1231444/docs#confirming-cyclopamine-kaad-target-engagement-a-comparative-technical-guide>]

Disclaimer & Data Validity:

The information provided in this document is for Research Use Only (RUO) and is strictly not intended for diagnostic or therapeutic procedures. While BenchChem strives to provide accurate protocols, we make no warranties, express or implied, regarding the fitness of this product for every specific experimental setup.

Technical Support: The protocols provided are for reference purposes. Unsure if this reagent suits your experiment?

Need Industrial/Bulk Grade? [Request Custom Synthesis Quote](#)

BenchChem

Our mission is to be the trusted global source of essential and advanced chemicals, empowering scientists and researchers to drive progress in science and industry.

Contact

Address: 3281 E Guasti Rd
Ontario, CA 91761, United States
Phone: (601) 213-4426
Email: info@benchchem.com

[Contact our Ph.D. Support Team for a compatibility check](#)