

Investigating the Binding Site of C3 Protein Interactors: A Methodological Overview

Author: BenchChem Technical Support Team. **Date:** April 2026

Compound of Interest

Compound Name: POT-4
Cat. No.: B12307322

[Get Quote](#)

Disclaimer: An initial search for the compound "**POT-4**" and its interaction with the C3 protein did not yield any specific publicly available scientific literature. Therefore, this guide will use the well-characterized C3 inhibitor, AMY-101 (a Compstatin analog), as a representative example to illustrate the requested technical content and methodologies. The data and protocols presented here are based on published research on AMY-101 and its interaction with the C3 protein.

This technical guide provides an in-depth overview of the experimental approaches used to characterize the binding of a therapeutic agent to the complement C3 protein. We will explore the methodologies for determining binding affinity, identifying the binding site, and elucidating the mechanism of action.

Quantitative Binding Data

The interaction between a ligand and its target protein is quantified by various parameters. The following table summarizes the key binding data for AMY-101 with C3 and its fragments.

Ligand	Target	Method	K_D (nM)	IC_50 (nM)	Reference
AMY-101	Human C3	Surface Plasmon Resonance (SPR)	0.5	-	
AMY-101	Human C3b	Surface Plasmon Resonance (SPR)	0.5	-	
AMY-101	Human C3c	Surface Plasmon Resonance (SPR)	1.2	-	
AMY-101	Baboon C3	Surface Plasmon Resonance (SPR)	0.6	-	
AMY-101	-	Alternative Pathway Hemolysis Assay	-	11	

Experimental Protocols

Detailed methodologies are crucial for the reproducibility of experimental results. Below are the protocols for key experiments used to characterize the AMY-101 and C3 interaction.

2.1. Surface Plasmon Resonance (SPR)

SPR is a label-free technique used to measure real-time biomolecular interactions.

- Objective: To determine the binding affinity (K_D), association rate (k_a), and dissociation rate (k_d) of AMY-101 to C3 and its fragments.

- Instrumentation: Biacore T200 (GE Healthcare) or similar.
- Methodology:
 - Immobilization: C3, C3b, or C3c is immobilized on a CM5 sensor chip via amine coupling.
 - Analyte Injection: A series of concentrations of AMY-101 in a running buffer (e.g., HBS-EP+) are injected over the sensor surface.
 - Data Collection: The change in the refractive index at the sensor surface is recorded as a function of time, generating a sensorgram.
 - Data Analysis: The sensorgrams are fitted to a 1:1 Langmuir binding model to determine the kinetic parameters (k_a , k_d) and the equilibrium dissociation constant (K_D).

2.2. X-ray Crystallography

This technique is used to determine the three-dimensional structure of the C3-AMY-101 complex at atomic resolution.

- Objective: To identify the specific amino acid residues of C3 that are involved in the interaction with AMY-101.
- Methodology:
 - Complex Formation: Purified C3 and AMY-101 are mixed in a stoichiometric ratio to form the complex.
 - Crystallization: The C3-AMY-101 complex is subjected to crystallization screening using various precipitants, buffers, and additives.
 - Data Collection: The resulting crystals are cryo-cooled and subjected to X-ray diffraction at a synchrotron source.
 - Structure Determination: The diffraction data is processed to solve the crystal structure of the complex, revealing the detailed interactions at the binding interface.

2.3. Hemolysis Assays

These functional assays are used to assess the inhibitory effect of AMY-101 on the complement cascade.

- Objective: To determine the half-maximal inhibitory concentration (IC₅₀) of AMY-101 for the alternative pathway of complement activation.
- Methodology:
 - Sensitization: Rabbit erythrocytes are washed and suspended in a buffer that facilitates alternative pathway activation (e.g., GVB/Mg-EGTA).
 - Inhibition: The sensitized erythrocytes are incubated with normal human serum (as a source of complement) in the presence of varying concentrations of AMY-101.
 - Lysis Measurement: The extent of erythrocyte lysis is determined by measuring the absorbance of the released hemoglobin at 412 nm.
 - IC₅₀ Calculation: The IC₅₀ value is calculated by plotting the percentage of hemolysis against the logarithm of the AMY-101 concentration.

Signaling Pathways and Experimental Workflows

Visual representations of complex biological pathways and experimental procedures can aid in understanding.

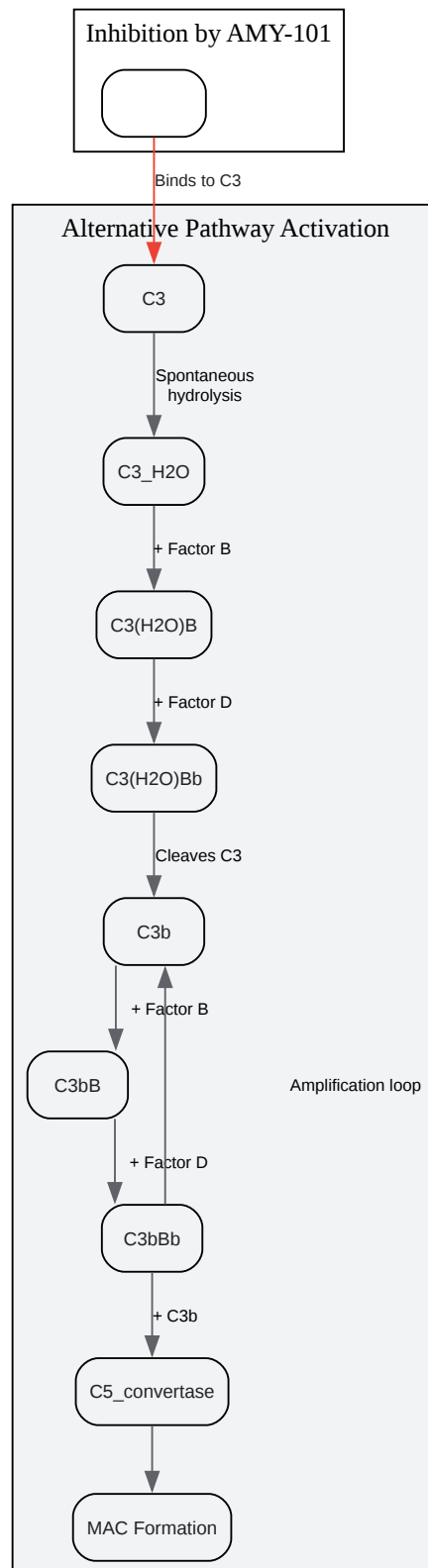

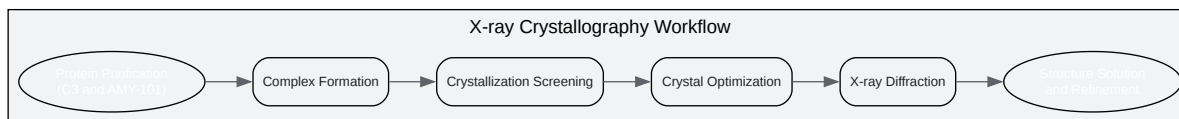

[Click to download full resolution via product page](#)

- To cite this document: BenchChem. [Investigating the Binding Site of C3 Protein Interactors: A Methodological Overview]. BenchChem, [2026]. [Online PDF]. Available at: [\[https://www.benchchem.com/product/b12307322/docs#investigating-the-binding-site-of-c3-protein-interactors-a-methodological-overview\]](https://www.benchchem.com/product/b12307322/docs#investigating-the-binding-site-of-c3-protein-interactors-a-methodological-overview)

Disclaimer & Data Validity:

The information provided in this document is for Research Use Only (RUO) and is strictly not intended for diagnostic or therapeutic procedures. While BenchChem strives to provide accurate protocols, we make no warranties, express or implied, regarding the fitness of this product for every specific experimental setup.

Technical Support: The protocols provided are for reference purposes. Unsure if this reagent suits your experiment?

Need Industrial/Bulk Grade? [Request Custom Synthesis Quote](#)

BenchChem

Our mission is to be the trusted global source of essential and advanced chemicals, empowering scientists and researchers to drive progress in science and industry.

Contact

Address: 3281 E Guasti Rd
Ontario, CA 91761, United States
Phone: (601) 213-4426
Email: info@benchchem.com

Contact our Ph.D. Support Team for a compatibility check