

Pulvomycin Technical Support Center: Identifying and Minimizing Off-Target Effects

Author: BenchChem Technical Support Team. **Date:** April 2026

Compound of Interest

Compound Name: *Pulvomycin*

Cat. No.: *B1230896*

[Get Quote](#)

This technical support center provides researchers, scientists, and drug development professionals with troubleshooting guides and FAQs to address potential issues when using **Pulvomycin**. The focus is on understanding and mitigating its off-target effects to ensure accurate experimental outcomes.

Frequently Asked Questions (FAQs)

Q1: What is the primary mechanism of action of **Pulvomycin**?

A1: **Pulvomycin** is an antibiotic that primarily targets the bacterial elongation factor Tu (EF-Tu). [1][2][3] It inhibits prokaryotic protein synthesis by preventing the formation of the crucial ternary complex consisting of EF-Tu, GTP, and aminoacyl-tRNA.[1][2] This action effectively blocks the delivery of amino acids to the ribosome, thereby halting protein production in bacteria.[1][4]

Q2: What are the known off-target effects of **Pulvomycin** in eukaryotic cells?

A2: A significant off-target effect of **Pulvomycin** in eukaryotic cells is the inhibition of the Signal Transducer and Activator of Transcription 3 (STAT3) signaling pathway.[5] **Pulvomycin** has been shown to suppress the activation of STAT3, which can lead to cell cycle arrest and

apoptosis in certain cancer cells.[5] This makes **Pulvomycin** a potential anti-cancer agent but also a source of confounding results in experiments where it is intended to be used solely as a prokaryotic protein synthesis inhibitor.

Q3: I am using **Pulvomycin** to study bacterial protein synthesis, but I am observing unexpected effects on my eukaryotic host cells. Why could this be happening?

A3: The unexpected effects on eukaryotic host cells are likely due to **Pulvomycin's** off-target inhibition of STAT3 signaling.[5] STAT3 is a key regulator of various cellular processes, including proliferation, survival, and inflammation. Inhibition of STAT3 can lead to a range of phenotypic changes that are independent of **Pulvomycin's** effect on bacterial protein synthesis.

Q4: How can I be sure that the phenotype I observe is due to the on-target (EF-Tu) or off-target (STAT3) effect of **Pulvomycin**?

A4: Distinguishing between on-target and off-target effects requires a combination of control experiments. A recommended approach is to use a rescue experiment or a secondary, structurally unrelated inhibitor. For example, to confirm an on-target effect in a co-culture system, you could attempt to rescue the eukaryotic cells by supplementing with a component that counteracts the downstream effects of bacterial growth inhibition. To validate an off-target effect on STAT3, you could use a known, specific STAT3 inhibitor as a positive control and observe if it phenocopies the effects of **Pulvomycin**. Additionally, genetic approaches like siRNA-mediated knockdown of STAT3 can help determine if the observed phenotype is dependent on this off-target.

Troubleshooting Guides

Problem 1: Inconsistent results in bacterial growth inhibition assays.

- Possible Cause: Degradation of **Pulvomycin**, inappropriate solvent, or incorrect concentration.
- Troubleshooting Steps:
 - Verify Stock Solution: Prepare fresh stock solutions of **Pulvomycin** in a suitable solvent like DMSO. Store aliquots at -20°C or lower to prevent degradation.

- Concentration Titration: Perform a dose-response experiment to determine the minimal inhibitory concentration (MIC) for your specific bacterial strain.
- Control for Solvent Effects: Include a vehicle control (e.g., DMSO alone) to ensure the solvent is not affecting bacterial growth.

Problem 2: Unexpected cytotoxicity in eukaryotic cell lines when using **Pulvomycin** as an antibacterial agent in co-culture experiments.

- Possible Cause: Off-target inhibition of STAT3 signaling by **Pulvomycin** is likely causing toxicity in the eukaryotic cells.^[5]
- Troubleshooting Steps:
 - Determine the IC50 for Eukaryotic Cells: Perform a cell viability assay (e.g., MTT or CellTiter-Glo) to determine the half-maximal inhibitory concentration (IC50) of **Pulvomycin** on your eukaryotic cell line.
 - Use the Lowest Effective Concentration: Use the lowest concentration of **Pulvomycin** that effectively inhibits bacterial growth while having a minimal toxic effect on the eukaryotic cells.
 - Employ a STAT3-null or STAT3-knockdown Cell Line: If available, use a cell line lacking STAT3 to confirm that the cytotoxicity is mediated by this off-target.
 - Consider an Alternative Antibiotic: If the off-target effects are unavoidable and interfere with the experimental goals, consider using an alternative antibiotic with a different mechanism of action.

Quantitative Data Summary

| Compound | Target | Assay Type | Cell Line/System | IC50 / Affinity | Reference |
|------------|---------------------------|----------------------------|--------------------------|-----------------|-----------|
| Pulvomycin | EF-Tu | In vitro protein synthesis | E. coli cell-free system | Not specified | [1][4] |
| Pulvomycin | STAT3 (antiproliferative) | Cell Viability | MDA-MB-231 (TNBC) | ~2.5 μ M | [5] |
| Pulvomycin | STAT3 (antiproliferative) | Cell Viability | Hs578T (TNBC) | ~3.0 μ M | [5] |
| Pulvomycin | STAT3 (antiproliferative) | Cell Viability | HCC38 (TNBC) | ~4.1 μ M | [5] |
| Pulvomycin | STAT3 (antiproliferative) | Cell Viability | HCC1937 (TNBC) | ~0.8 μ M | [5] |

Note: Specific binding affinities (e.g., Kd values) for **Pulvomycin** with EF-Tu and STAT3 are not readily available in the public domain and may need to be determined empirically.

Experimental Protocols

Protocol 1: In Vitro Bacterial Protein Synthesis Inhibition Assay

Objective: To determine the inhibitory effect of **Pulvomycin** on bacterial protein synthesis in a cell-free system.

Methodology:

- Prepare a Bacterial Cell-Free Extract (S30 Extract):

- Grow a suitable bacterial strain (e.g., *E. coli*) to mid-log phase.
- Harvest the cells by centrifugation and wash them with a suitable buffer.
- Lyse the cells using a French press or sonication.
- Centrifuge the lysate at 30,000 x g to pellet cell debris. The supernatant is the S30 extract.
- Set up the In Vitro Translation Reaction:
 - In a microcentrifuge tube, combine the S30 extract, a buffer containing ATP, GTP, and an ATP regenerating system, a mixture of amino acids (including a radiolabeled amino acid like ³⁵S-methionine), and a template mRNA (e.g., luciferase mRNA).
 - Prepare a dilution series of **Pulvomycin** in DMSO.
 - Add the **Pulvomycin** dilutions or vehicle control to the reaction tubes.
- Incubation:
 - Incubate the reactions at 37°C for 30-60 minutes.
- Quantification of Protein Synthesis:
 - Stop the reaction by adding trichloroacetic acid (TCA) to precipitate the newly synthesized proteins.
 - Collect the precipitate on a filter membrane and wash to remove unincorporated radiolabeled amino acids.
 - Measure the radioactivity of the filter using a scintillation counter.
- Data Analysis:
 - Calculate the percentage of inhibition of protein synthesis for each **Pulvomycin** concentration relative to the vehicle control.
 - Plot the percentage of inhibition against the **Pulvomycin** concentration and determine the IC50 value.

Protocol 2: Western Blot for STAT3 Phosphorylation

Objective: To assess the effect of **Pulvomycin** on STAT3 activation in eukaryotic cells.

Methodology:

- Cell Culture and Treatment:
 - Plate your eukaryotic cells of interest and grow them to 70-80% confluency.
 - Treat the cells with various concentrations of **Pulvomycin** or a vehicle control for a specified time (e.g., 6-24 hours).
 - Include a positive control for STAT3 activation (e.g., treatment with a cytokine like IL-6) and a known STAT3 inhibitor as a negative control.
- Cell Lysis:
 - Wash the cells with ice-cold PBS and lyse them in RIPA buffer supplemented with protease and phosphatase inhibitors.
 - Collect the cell lysates and determine the protein concentration using a BCA or Bradford assay.
- SDS-PAGE and Western Blotting:
 - Denature the protein lysates by boiling in Laemmli buffer.
 - Separate the proteins by SDS-polyacrylamide gel electrophoresis (SDS-PAGE).
 - Transfer the proteins to a PVDF or nitrocellulose membrane.
- Immunoblotting:
 - Block the membrane with 5% non-fat milk or BSA in TBST.
 - Incubate the membrane with a primary antibody specific for phosphorylated STAT3 (p-STAT3, Tyr705).

- Wash the membrane and incubate with a horseradish peroxidase (HRP)-conjugated secondary antibody.
- Develop the blot using an enhanced chemiluminescence (ECL) substrate and image the signal.
- Stripping and Re-probing:
 - Strip the membrane and re-probe with a primary antibody for total STAT3 to normalize for protein loading.
 - It is also recommended to probe for a loading control like β -actin or GAPDH.
- Data Analysis:
 - Quantify the band intensities for p-STAT3 and total STAT3.
 - Calculate the ratio of p-STAT3 to total STAT3 for each treatment condition to determine the effect of **Pulvomycin** on STAT3 phosphorylation.

Visualizations

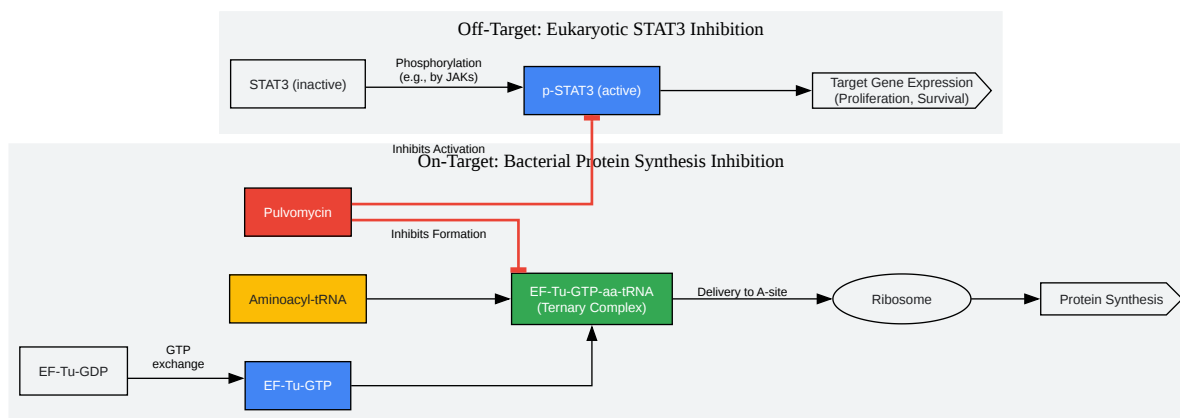

[Click to download full resolution via product page](#)

Caption: On-target and off-target mechanisms of **Pulvomycin**.



[Click to download full resolution via product page](#)

Caption: Troubleshooting workflow for **Pulvomycin**-induced phenotypes.

Need Custom Synthesis?

BenchChem offers custom synthesis for rare earth carbides and specific isotopic labeling.

Email: info@benchchem.com or [Request Quote Online](#).

References

- [1. pubs.acs.org \[pubs.acs.org\]](https://pubs.acs.org)
- [2. Pulvomycin, an inhibitor of protein biosynthesis preventing ternary complex formation between elongation factor Tu, GTP, and aminoacyl-tRNA - PMC \[pmc.ncbi.nlm.nih.gov\]](https://pubmed.ncbi.nlm.nih.gov/123456789/)
- [3. Sensitivity of elongation factor Tu \(EF-Tu\) from different bacterial species to the antibiotics efrotomycin, pulvomycin and MDL 62879 - PubMed \[pubmed.ncbi.nlm.nih.gov\]](https://pubmed.ncbi.nlm.nih.gov/123456789/)
- [4. benchchem.com \[benchchem.com\]](https://www.benchchem.com)
- [5. Structural basis of the action of pulvomycin and GE2270 A on elongation factor Tu - PubMed \[pubmed.ncbi.nlm.nih.gov\]](https://pubmed.ncbi.nlm.nih.gov/123456789/)
- To cite this document: BenchChem. [Pulvomycin Technical Support Center: Identifying and Minimizing Off-Target Effects]. BenchChem, [2026]. [Online PDF]. Available at: [\[https://www.benchchem.com/product/b1230896/docs#pulvomycin-technical-support-center-identifying-and-minimizing-off-target-effects\]](https://www.benchchem.com/product/b1230896/docs#pulvomycin-technical-support-center-identifying-and-minimizing-off-target-effects)

Disclaimer & Data Validity:

The information provided in this document is for Research Use Only (RUO) and is strictly not intended for diagnostic or therapeutic procedures. While BenchChem strives to provide accurate protocols, we make no warranties, express or implied, regarding the fitness of this product for every specific experimental setup.

Technical Support: The protocols provided are for reference purposes. Unsure if this reagent suits your experiment?

Need Industrial/Bulk Grade? [Request Custom Synthesis Quote](#)

BenchChem

Our mission is to be the trusted global source of essential and advanced chemicals, empowering scientists and researchers to drive progress in science and industry.

Contact

Address: 3281 E Guasti Rd

Ontario, CA 91761, United States

Phone: (601) 213-4426

Email: info@benchchem.com

[Contact our Ph.D. Support Team for a compatibility check](#)