

# Pulvomycin: A Technical Guide to a Multifaceted Polyketide

**Author:** BenchChem Technical Support Team. **Date:** April 2026

## Compound of Interest

Compound Name: *Pulvomycin*

Cat. No.: *B1230896*

[Get Quote](#)

For Researchers, Scientists, and Drug Development Professionals

## Abstract

**Pulvomycin** is a macrocyclic polyketide antibiotic with a significant history and renewed interest due to its diverse biological activities. Initially identified as an inhibitor of bacterial protein synthesis, recent studies have illuminated its potential as an anticancer agent through the inhibition of critical signaling pathways. This technical guide provides an in-depth overview of **Pulvomycin**, focusing on its identification, mechanism of action, biosynthesis, and relevant experimental methodologies. All quantitative data is presented in structured tables, and key processes are visualized using diagrams to facilitate a comprehensive understanding for research and development applications.

## Identification and Physicochemical Properties

Accurate identification of a compound is critical for research and regulatory purposes. The Chemical Abstracts Service (CAS) has assigned a unique registry number to **Pulvomycin** for its definitive identification in literature and databases.

CAS Number: 11006-66-9[1][2][3][4]

The fundamental physicochemical properties of **Pulvomycin** are summarized below.

Property	Value	Source
CAS Number	11006-66-9	[1][2][3][4]
Molecular Formula	C47H66O13	[1][5]
Molecular Weight	839.03 g/mol	[1][5]
Exact Mass	838.4503 g/mol	[1][5]
Synonyms	Labilomycin, 1063-Z	[5][6][7]

## Mechanism of Action

**Pulvomycin** exhibits distinct mechanisms of action against prokaryotic and eukaryotic cells, making it a molecule of significant interest for both infectious disease and oncology research.

### Antibacterial Activity: Inhibition of Protein Biosynthesis

In prokaryotes, **Pulvomycin's** primary target is the elongation factor Tu (EF-Tu), a crucial protein in the translation process.[6][7][8] It inhibits protein biosynthesis by preventing the formation of the ternary complex, which consists of EF-Tu, guanosine triphosphate (GTP), and an aminoacyl-tRNA.[6][7][8] By binding to EF-Tu, **Pulvomycin** effectively blocks the delivery of aminoacyl-tRNA to the ribosome, thereby halting polypeptide chain elongation.[6][7][9]

The following diagram illustrates the inhibitory action of **Pulvomycin** on the bacterial translation elongation cycle.

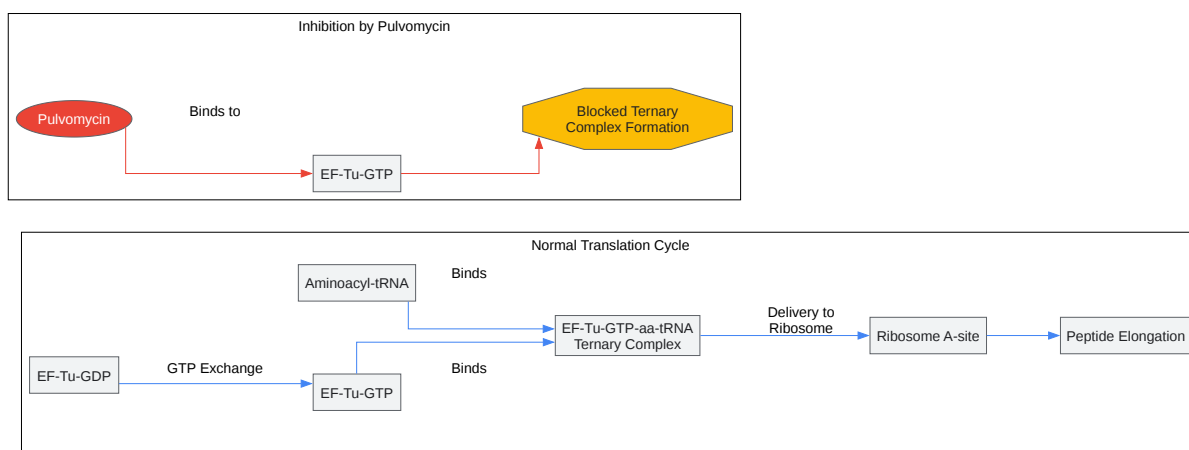

[Click to download full resolution via product page](#)

**Pulvomycin's** inhibition of the bacterial translation elongation cycle.

## Anticancer Activity: STAT3 Signaling Pathway Inhibition

In the context of cancer, particularly in docetaxel-resistant triple-negative breast cancer (TNBC) cells, **Pulvomycin** acts as a novel inhibitor of the Signal Transducer and Activator of Transcription 3 (STAT3) signaling pathway.[10] It effectively suppresses the activation of STAT3 by inhibiting its phosphorylation at tyrosine 705 (p-STAT3 Y705).[10] This inhibition leads to

downstream effects including cell cycle arrest at the G0/G1 phase, induction of apoptosis, and regulation of the epithelial-mesenchymal transition (EMT) pathway.[10]

The diagram below outlines the STAT3 signaling pathway and the point of inhibition by **Pulvomycin**.

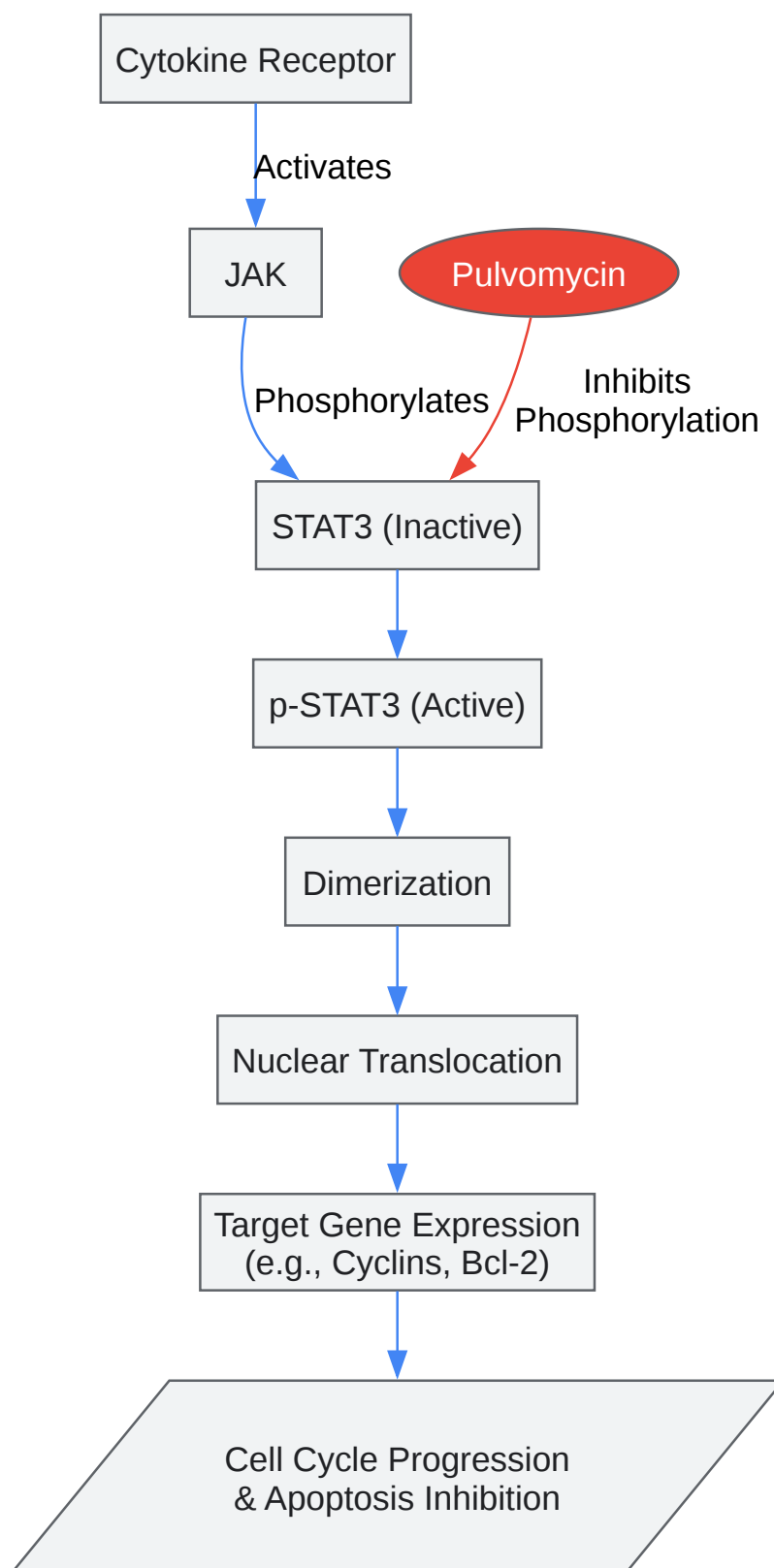

[Click to download full resolution via product page](#)

Inhibition of the STAT3 signaling pathway by **Pulvomycin**.

## Biosynthesis

**Pulvomycin** is a natural product synthesized by certain species of *Streptomyces*.<sup>[10][11][12]</sup> Its complex structure is assembled via a trans-acyltransferase polyketide synthase (trans-AT PKS) biosynthetic pathway.<sup>[11][12]</sup> Genomic analysis of the producing strain, *Streptomyces* sp. HRS33, has successfully identified the biosynthetic gene cluster responsible for its production.<sup>[11][12]</sup> This pathway involves the sequential condensation of small carboxylic acid-derived units to build the complex polyketide backbone, which is then cyclized and further modified to yield the final 22-membered macrocyclic lactone structure.<sup>[11][13]</sup>

## Biological Activity: Quantitative Data

**Pulvomycin** and its analogs have demonstrated potent cytotoxic activity against various human cancer cell lines. The half-maximal inhibitory concentration (IC<sub>50</sub>) values highlight its potential as an anticancer agent.

Cell Line	Cancer Type	IC <sub>50</sub> (μM)	Source
MDA-MB-231	Triple-Negative Breast Cancer	~2.5	[10]
MDA-MB-231-DTR	Docetaxel-Resistant TNBC	~1.8	[10]
A549	Lung Carcinoma	0.8	[10]
HCT116	Colon Carcinoma	4.1	[10]

## Key Experimental Protocols

The characterization of **Pulvomycin**'s biological activity involves a range of standard and advanced molecular biology and synthetic chemistry techniques.

### Western Blot Analysis for STAT3 Inhibition

This protocol is used to determine the effect of **Pulvomycin** on protein expression levels, specifically p-STAT3 and total STAT3.

- Cell Culture and Treatment: Culture cancer cells (e.g., MDA-MB-231-DTR) to ~80% confluency. Treat cells with varying concentrations of **Pulvomycin** (e.g., 0, 1, 2, 4  $\mu$ M) for 24 hours.
- Protein Extraction: Lyse the treated cells using RIPA buffer containing protease and phosphatase inhibitors.
- Quantification: Determine the protein concentration of the lysates using a Bradford assay.[10]
- SDS-PAGE: Separate 20-30  $\mu$ g of protein from each sample on a 10% SDS-polyacrylamide gel.
- Protein Transfer: Transfer the separated proteins from the gel to a polyvinylidene difluoride (PVDF) membrane.
- Blocking and Antibody Incubation: Block the membrane with 5% skim milk or bovine serum albumin (BSA) in Tris-buffered saline with Tween 20 (TBST) for 1 hour. Incubate the membrane with primary antibodies against p-STAT3 (Y705), STAT3, and a loading control (e.g.,  $\beta$ -actin) overnight at 4°C.
- Secondary Antibody and Detection: Wash the membrane with TBST and incubate with a horseradish peroxidase (HRP)-conjugated secondary antibody for 1 hour. Detect the protein bands using an enhanced chemiluminescence (ECL) detection system.
- Analysis: Quantify band intensities using software such as ImageJ.[10]

## Total Synthesis of Pulvomycin D

The total synthesis of **Pulvomycin D**, an analog, was a significant achievement demonstrating a viable synthetic route to this class of molecules.[14][15] A key step in the process is the macrocyclization to form the 22-membered ring.

The workflow below outlines the high-level strategy for the total synthesis of **Pulvomycin D**.

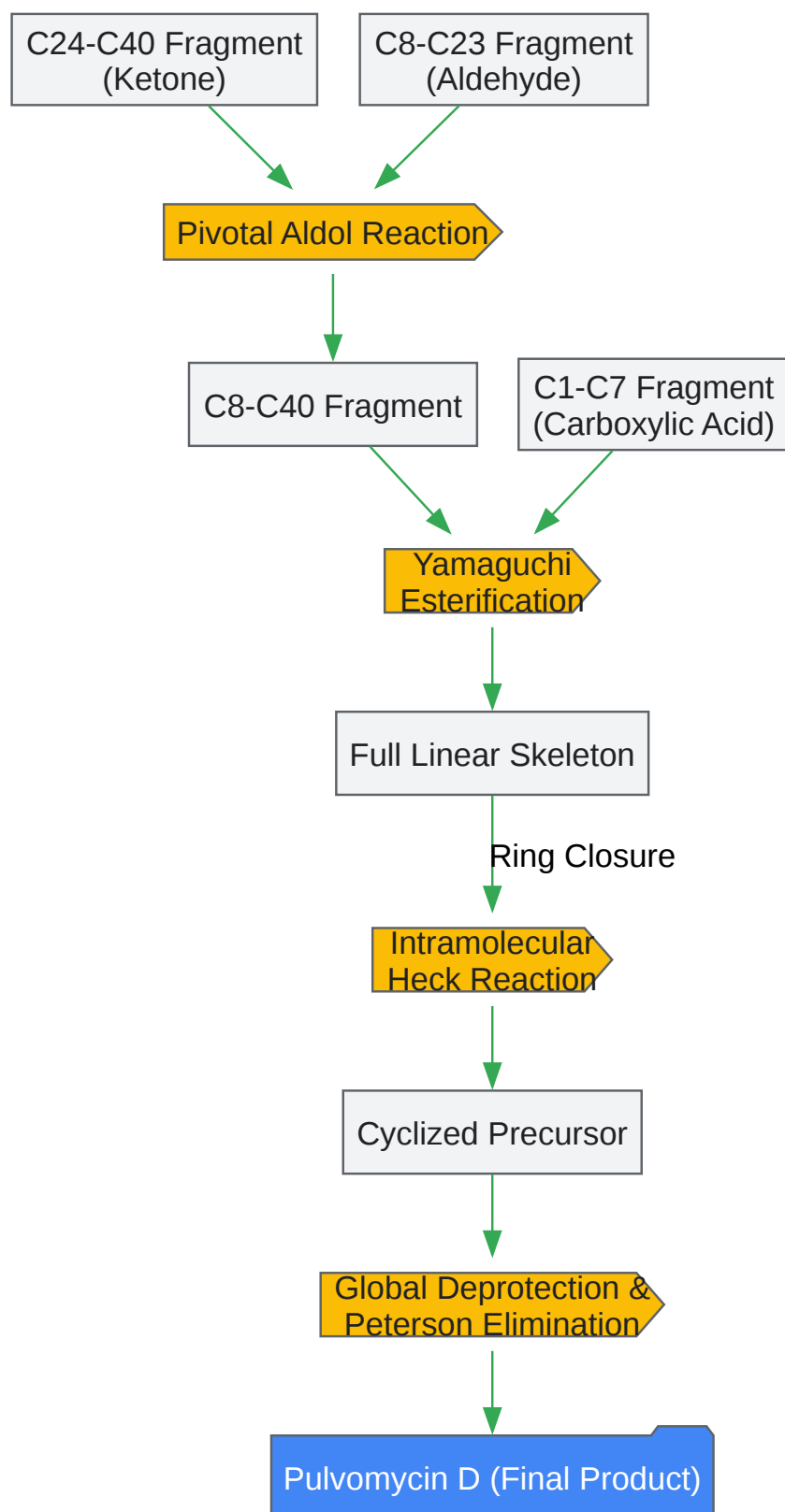

[Click to download full resolution via product page](#)

High-level workflow for the total synthesis of **Pulvomycin D**.

- **Fragment Assembly:** Synthesize three key fragments (C1-C7, C8-C23, and C24-C40) through multi-step sequences.
- **Aldol Reaction:** Couple the C24-C40 and C8-C23 fragments via a pivotal aldol reaction.[\[14\]](#)  
[\[15\]](#)
- **Yamaguchi Esterification:** Attach the C1-C7 fragment to the combined C8-C40 segment using the Yamaguchi protocol, which is efficient for forming esters from sterically hindered alcohols and carboxylic acids.[\[14\]](#)[\[16\]](#)
- **Intramolecular Heck Reaction:** Perform the key macrocyclization step using an intramolecular Heck reaction to form the 22-membered lactone ring.[\[14\]](#)[\[15\]](#)
- **Deprotection and Elimination:** Conduct a final global deprotection to remove all silyl protecting groups, combined with a Peterson elimination to form a crucial olefin, yielding the final natural product.[\[14\]](#)[\[15\]](#)

## Conclusion

**Pulvomycin** is a compelling natural product with well-defined antibacterial and emerging anticancer properties. Its unique ability to inhibit bacterial protein synthesis and the STAT3 signaling pathway in cancer cells provides a dual framework for therapeutic development. The successful total synthesis of a **Pulvomycin**-class molecule opens avenues for analog creation and structure-activity relationship (SAR) studies. This guide provides the core technical information necessary for researchers to further explore the potential of **Pulvomycin** in drug discovery and development.

### *Need Custom Synthesis?*

*BenchChem offers custom synthesis for rare earth carbides and specific isotopic labeling.*

*Email: [info@benchchem.com](mailto:info@benchchem.com) or [Request Quote Online](#).*

## References

- [1. medkoo.com](https://www.medkoo.com) [\[medkoo.com\]](#)

- [2. Pulvomycin, CasNo.11006-66-9 Shanghai Scochem Technology Co., Ltd. China \(Mainland\) \[shop407048.lookchem.com\]](#)
- [3. Pulvomycin | 11006-66-9 \[chemicalbook.com\]](#)
- [4. Pulvomycin CAS#: 11006-66-9 \[m.chemicalbook.com\]](#)
- [5. Pulvomycin | C47H66O13 | CID 5282056 - PubChem \[pubchem.ncbi.nlm.nih.gov\]](#)
- [6. Pulvomycin, an inhibitor of protein biosynthesis preventing ternary complex formation between elongation factor Tu, GTP, and aminoacyl-tRNA - PubMed \[pubmed.ncbi.nlm.nih.gov\]](#)
- [7. Pulvomycin, an inhibitor of protein biosynthesis preventing ternary complex formation between elongation factor Tu, GTP, and aminoacyl-tRNA - PMC \[pmc.ncbi.nlm.nih.gov\]](#)
- [8. The Comprehensive Antibiotic Resistance Database \[card.mcmaster.ca\]](#)
- [9. Pulvomycin, an inhibitor of prokaryotic protein biosynthesis - PubMed \[pubmed.ncbi.nlm.nih.gov\]](#)
- [10. Antitumor Activity of Pulvomycin via Targeting Activated-STAT3 Signaling in Docetaxel-Resistant Triple-Negative Breast Cancer Cells - PMC \[pmc.ncbi.nlm.nih.gov\]](#)
- [11. pubs.acs.org \[pubs.acs.org\]](#)
- [12. pubs.acs.org \[pubs.acs.org\]](#)
- [13. Collection - Structures and Biosynthetic Pathway of Pulvomycins Bâ<sup>FAESTS</sup>D: 22-Membered Macrolides from an Estuarine Streptomyces sp. - Organic Letters - Figshare \[acs.figshare.com\]](#)
- [14. Total Synthesis of Pulvomycin D - PubMed \[pubmed.ncbi.nlm.nih.gov\]](#)
- [15. Total Synthesis of Pulvomycin D - PMC \[pmc.ncbi.nlm.nih.gov\]](#)
- [16. researchgate.net \[researchgate.net\]](#)
- To cite this document: BenchChem. [Pulvomycin: A Technical Guide to a Multifaceted Polyketide]. BenchChem, [2026]. [Online PDF]. Available at: [\[https://www.benchchem.com/product/b1230896/docs#pulvomycin-a-technical-guide-to-a-multifaceted-polyketide\]](https://www.benchchem.com/product/b1230896/docs#pulvomycin-a-technical-guide-to-a-multifaceted-polyketide)

---

### Disclaimer & Data Validity:

The information provided in this document is for Research Use Only (RUO) and is strictly not intended for diagnostic or therapeutic procedures. While BenchChem strives to provide

accurate protocols, we make no warranties, express or implied, regarding the fitness of this product for every specific experimental setup.

**Technical Support:** The protocols provided are for reference purposes. Unsure if this reagent suits your experiment?

**Need Industrial/Bulk Grade?** [Request Custom Synthesis Quote](#)

## BenchChem

Our mission is to be the trusted global source of essential and advanced chemicals, empowering scientists and researchers to drive progress in science and industry.

### Contact

Address: 3281 E Guasti Rd

Ontario, CA 91761, United States

Phone: (601) 213-4426

Email: [info@benchchem.com](mailto:info@benchchem.com)

[Contact our Ph.D. Support Team for a compatibility check](#)