

Application Notes & Protocols: Dynamic Nuclear Polarization with Cross-Polarization (DNPC) in NMR Spectroscopy

Author: BenchChem Technical Support Team. **Date:** May 2026

Compound of Interest

Compound Name:	1,2- <i>Dinonanoylphosphatidylcholine</i>
CAS No.:	27869-45-0
Cat. No.:	B1230402

[Get Quote](#)

Abstract

Nuclear Magnetic Resonance (NMR) spectroscopy is an unparalleled technique for elucidating molecular structure and dynamics at an atomic level.[1][2] However, its utility, particularly in the solid state, has historically been constrained by its inherent low sensitivity.[3][4][5] Dynamic Nuclear Polarization (DNP) has emerged as a transformative hyperpolarization technique, dramatically overcoming this limitation by transferring the large spin polarization of electrons to nuclear spins, boosting NMR signals by orders of magnitude.[6][7][8] This guide focuses on the synergistic combination of DNP with Cross-Polarization (CP), a workflow we term DNPC. This powerful pairing first enhances the polarization of abundant nuclei like protons (^1H) via DNP and then efficiently transfers this enhanced polarization to dilute, low-gyromagnetic-ratio nuclei such as ^{13}C and ^{15}N via CP. This DNPC approach is the cornerstone of modern high-sensitivity solid-state NMR (ssNMR), enabling previously infeasible studies in structural biology, materials science, and pharmaceutical development.[9][10]

The Principle of DNPC: A Two-Stage Signal Amplification

The low sensitivity of NMR stems from the small population difference between nuclear spin states, even in the strongest magnetic fields.^[11] DNPC tackles this challenge through a powerful two-step process.

Step 1: Dynamic Nuclear Polarization (DNP) The process begins by introducing a stable paramagnetic polarizing agent (PA), typically a biradical, into the sample.^{[12][13]} At cryogenic temperatures (~100 K) and under high magnetic fields, the electron spins of this radical are almost fully polarized. By irradiating the sample with microwaves at a frequency close to the electron paramagnetic resonance (EPR) transition, this massive polarization is transferred to the surrounding nuclear spins, typically ^1H .^{[7][14]} The primary mechanism for this transfer in modern high-field DNP is the Cross-Effect (CE), which is highly efficient when using tailored biradicals.^{[8][12][15]} This initial step can increase the proton polarization by a factor of 100 to 200, which translates to a reduction in experiment time by a factor of 10,000 to 40,000.^{[8][12]}

Step 2: Cross-Polarization (CP) While the protons are now hyperpolarized, the nuclei of primary interest in structural studies (e.g., ^{13}C , ^{15}N) are still at thermal equilibrium. Cross-Polarization is a standard ssNMR technique used to transfer magnetization from abundant spins (^1H) to dilute spins (X-nuclei like ^{13}C , ^{15}N).^[10] This is achieved by applying radiofrequency (RF) fields to both ^1H and X channels simultaneously, satisfying the Hartmann-Hahn matching condition. The DNP-enhanced proton polarization is thus efficiently transferred to the target nuclei, resulting in a dramatically amplified signal for these crucial nuclei.

The entire DNPC workflow represents a cascade of polarization, making it possible to obtain high-resolution spectra of insensitive nuclei in a fraction of the time required by conventional ssNMR.

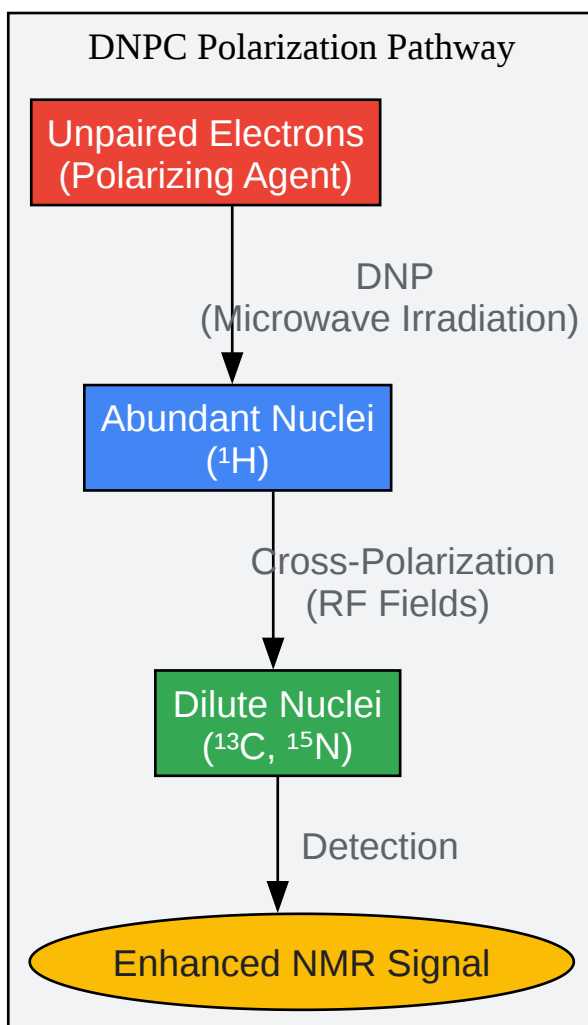

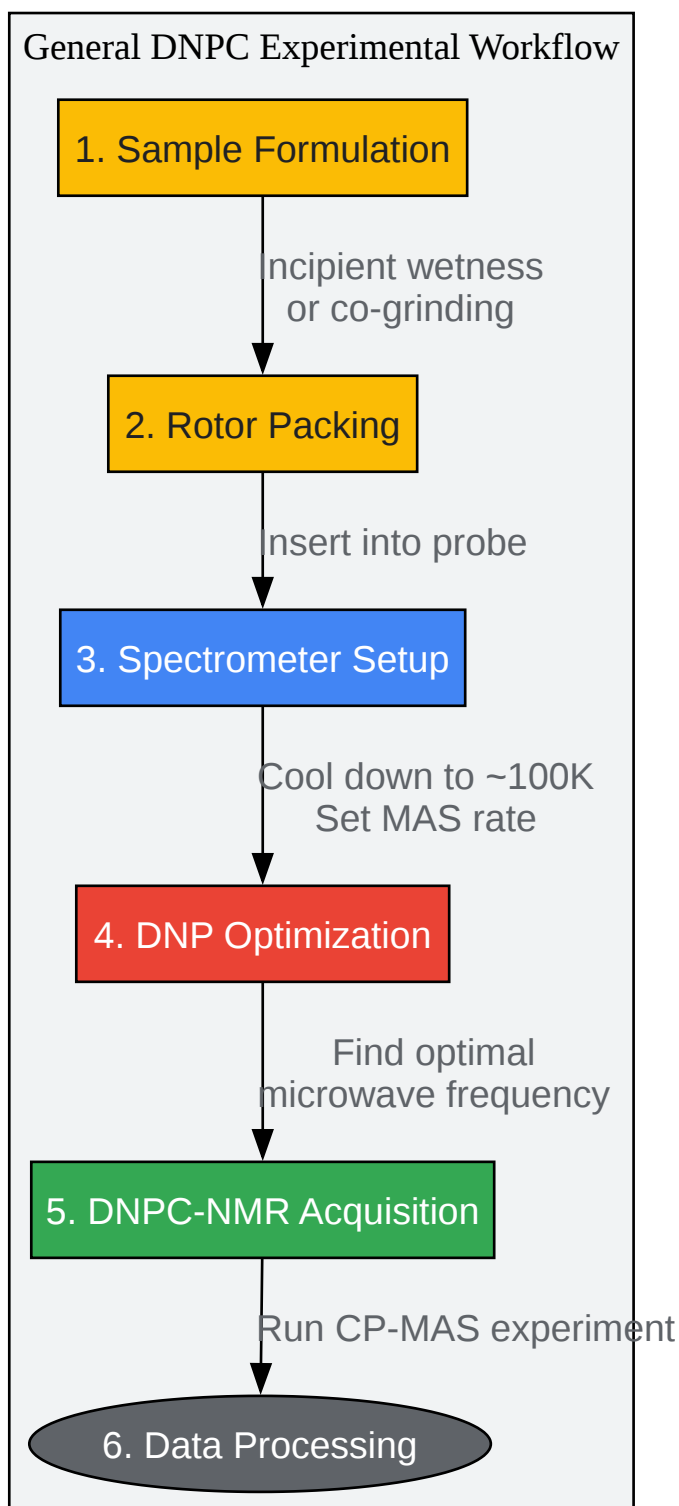

[Click to download full resolution via product page](#)

Need Custom Synthesis?

BenchChem offers custom synthesis for rare earth carbides and specific isotopic labeling.

Email: info@benchchem.com or [Request Quote Online](#).

Sources

- [1. Nuclear magnetic resonance spectroscopy - Wikipedia \[en.wikipedia.org\]](#)
- [2. longdom.org \[longdom.org\]](#)
- [3. weizmann.elsevierpure.com \[weizmann.elsevierpure.com\]](#)
- [4. annualreviews.org \[annualreviews.org\]](#)
- [5. researchgate.net \[researchgate.net\]](#)
- [6. pubs.acs.org \[pubs.acs.org\]](#)
- [7. bridge12.com \[bridge12.com\]](#)
- [8. Dynamic nuclear polarization \(DNP\) - NMR-Festkörperspektroskopie - AG Corzilius - University of Rostock \[corzilius.chemie.uni-rostock.de\]](#)
- [9. Dynamic Nuclear Polarization Solid-State NMR Spectroscopy for Materials Research: Abstract, Citation \(BibTeX\) & Reference | Bohrium \[bohrium.com\]](#)
- [10. Experimental Approaches of NMR Spectroscopy | springerprofessional.de \[springerprofessional.de\]](#)
- [11. Dynamic Nuclear Polarization \(DNP\) | The Vega Group \[weizmann.ac.il\]](#)
- [12. Dynamic Nuclear Polarization | Solid State NMR | Bruker \[bruker.com\]](#)
- [13. Sample preparation strategies dnp experiments | Bruker \[bruker.com\]](#)
- [14. Dynamic Nuclear Polarization – NYSBC \[nysbc.org\]](#)
- [15. Dynamic Nuclear Polarization in Solid State NMR - The Science Snail \[sciencesnail.com\]](#)
- To cite this document: BenchChem. [Application Notes & Protocols: Dynamic Nuclear Polarization with Cross-Polarization (DNPC) in NMR Spectroscopy]. BenchChem, [2026]. [Online PDF]. Available at: [\[https://www.benchchem.com/product/b1230402/docs#application-notes-protocols-dynamic-nuclear-polarization-with-cross-polarization-dnpc-in-nmr-spectroscopy\]](https://www.benchchem.com/product/b1230402/docs#application-notes-protocols-dynamic-nuclear-polarization-with-cross-polarization-dnpc-in-nmr-spectroscopy)

Disclaimer & Data Validity:

The information provided in this document is for Research Use Only (RUO) and is strictly not intended for diagnostic or therapeutic procedures. While BenchChem strives to provide accurate protocols, we make no warranties, express or implied, regarding the fitness of this product for every specific experimental setup.

Technical Support: The protocols provided are for reference purposes. Unsure if this reagent suits your experiment?

Need Industrial/Bulk Grade? [Request Custom Synthesis Quote](#)

BenchChem

Our mission is to be the trusted global source of essential and advanced chemicals, empowering scientists and researchers to drive progress in science and industry.

Contact

Address: 3281 E Guasti Rd
Ontario, CA 91761, United States
Phone: (601) 213-4426
Email: info@benchchem.com

[Contact our Ph.D. Support Team for a compatibility check](#)