

# Technical Support Center: Epicinchonidine Stereoselectivity Optimization

**Author:** BenchChem Technical Support Team. **Date:** March 2026

## Compound of Interest

Compound Name: *Epicinchonidine*

CAS No.: 550-54-9

Cat. No.: B123159

[Get Quote](#)

Topic: Effect of Temperature on **Epicinchonidine** Stereoselectivity Ticket ID: #EPI-T9-OPT  
Assigned Specialist: Senior Application Scientist, Chiral Catalysis Unit

## Executive Summary: The Thermodynamics of Selectivity

Welcome to the technical guide for optimizing **Epicinchonidine** (specifically 9-epi-cinchonidine and its derivatives) mediated catalysis. Unlike standard Cinchona alkaloids, the "epi" series possesses a distinct C9-stereochemistry (typically 8S, 9S) that alters the conformation of the quinuclidine nitrogen relative to the quinoline ring.

Temperature is not merely a kinetic switch; it is the primary lever for manipulating the Differential Activation Free Energy (

) . In organocatalysis, stereoselectivity is governed by the competition between enthalpy (

) and entropy (

) terms:

Key Insight: Lowering the temperature generally increases the enantiomeric ratio (

) because the enthalpic term (

)—derived from specific H-bonding interactions in the transition state—becomes more dominant over the entropic disorder term (

). However, users must be vigilant for the Isokinetic Temperature (

), where selectivity can vanish or invert.

## Troubleshooting Guide & FAQs

### Scenario A: "My enantiomeric excess (ee) is stalling below 80% despite using standard protocols."

Diagnosis: The reaction is likely operating under Entropy Control or suffering from a Background Racemic Reaction.

Q1: I am running the reaction at Room Temperature (25°C). Should I cool it down?

- Answer: Yes. For **Epicinchonidine**-catalyzed Michael additions or Aldol reactions, a temperature drop to -20°C or -40°C often results in a significant boost in ee.
  - Mechanism:[\[1\]](#)[\[2\]](#)[\[3\]](#)[\[4\]](#)[\[5\]](#)[\[6\]](#) The rigid chiral pocket formed by the catalyst binds the substrate more tightly (enthalpy) at lower temperatures, excluding the "mismatched" transition state.
  - Action: Perform a "Temperature Scan" (0°C, -20°C, -40°C, -78°C). Plot  
  
vs.  
  
. Linearity confirms standard Arrhenius behavior.

Q2: I cooled the reaction to -78°C, but the yield dropped to <10%.

- Answer: You have hit the Reactivity Wall. At extremely low temperatures, the catalytic turnover frequency (TOF) drops because the system lacks the thermal energy to cross the activation barrier ( ).
  - Action: Increase catalyst loading (from 5 mol% to 10-15 mol%) or increase concentration (if solubility permits). Alternatively, find the "Goldilocks Zone" (usually -20°C to -40°C)

where ee is acceptable and rate is practical.

## Scenario B: "The stereochemistry flipped! I got the (R)-product at high temp and (S)-product at low temp."

Diagnosis: You have crossed the Isokinetic Temperature ( ).

Q3: Is it possible for temperature to invert chirality?

- Answer: Yes. This occurs when the Enthalpy ( ) and Entropy ( ) terms favor opposite enantiomers.
  - High T: Entropy dominates ( ). The "looser" transition state is favored.
  - Low T: Enthalpy dominates ( ). The "tighter," better H-bonded transition state is favored.
  - Action: If you need the low-temp enantiomer, stay well below . If you need the high-temp enantiomer, ensure your catalyst is stable at that elevated temperature (Cinchona alkaloids are generally stable up to 60-80°C).

## Scenario C: "My results are inconsistent between batches."

Diagnosis: Thermal Fluctuations or Solubility Issues.

Q4: How sensitive is **Epincinchonidine** to minor temperature changes?

- Answer: Highly sensitive. A fluctuation of  $\pm 5^{\circ}\text{C}$  can shift the ee by 2-5% depending on the substrate.

- Action: Use a cryostat or a precise chilling block, not just an ice/salt bath which warms over time.
- Check: Ensure the catalyst is fully dissolved. At low temperatures, **Epicinchonidine** derivatives (especially thioureas) can precipitate, leading to a heterogeneous reaction which often has lower selectivity (or acts as a racemic background scavenger).

## Visualizing the Decision Matrix

The following diagram illustrates the troubleshooting workflow for optimizing stereoselectivity based on temperature response.

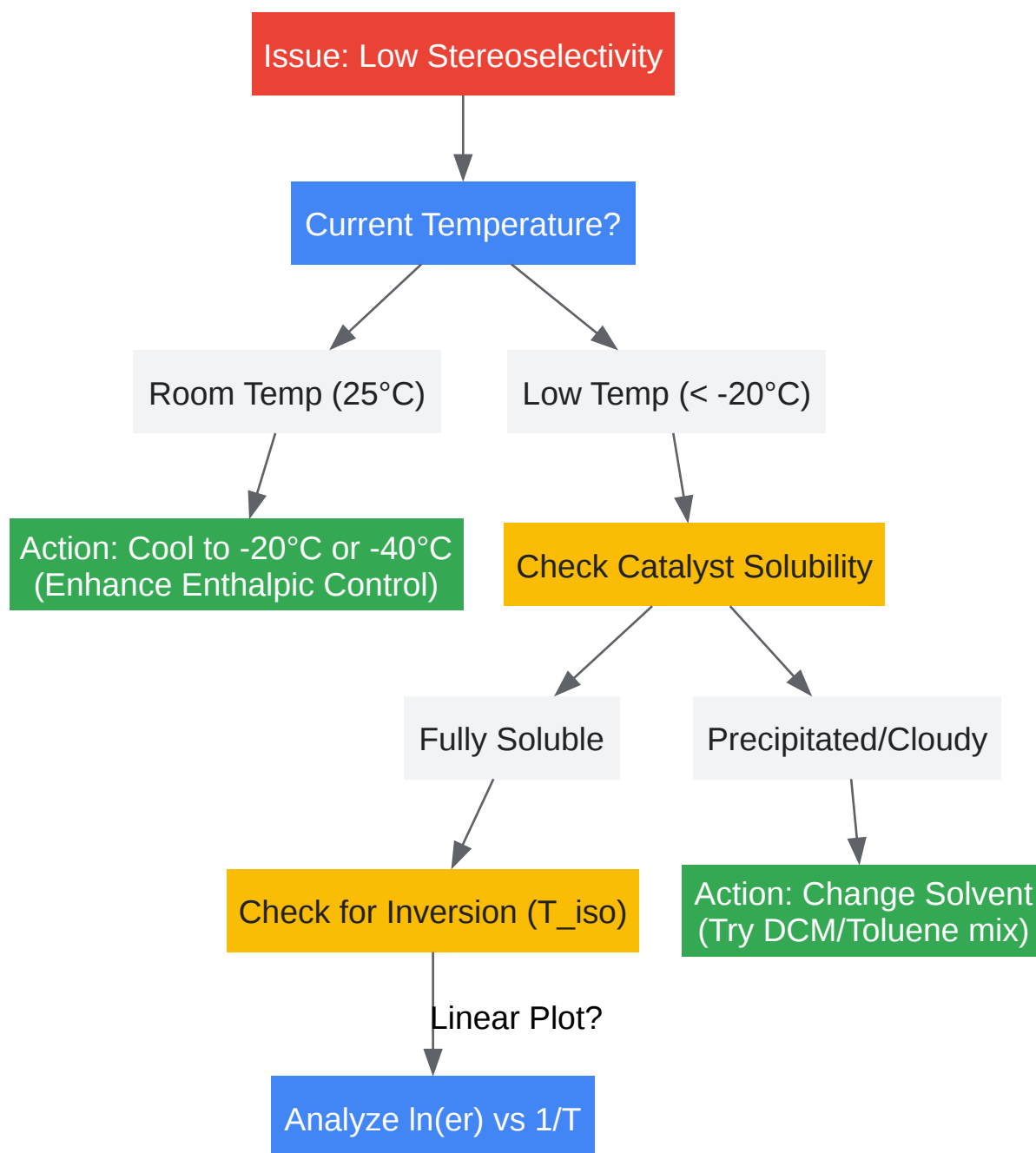

[Click to download full resolution via product page](#)

Caption: Workflow for diagnosing temperature-dependent stereoselectivity failures in organocatalysis.

## Standardized Experimental Protocol

Protocol: Enantioselective Michael Addition using 9-amino-9-deoxy-epi-cinchonidine. Objective: Maximize ee via Temperature Control.

#### Materials:

- Catalyst: 9-amino-9-deoxy-epi-cinchonidine (10 mol%)
- Acid Additive: TFA (20 mol%) - Crucial for amine activation mechanism.
- Solvent: Toluene or DCM (Anhydrous).
- Substrates: Enone and Malonate/Nitroalkane.

#### Step-by-Step Procedure:

- Catalyst Prep: In a flame-dried vial, dissolve the catalyst (0.05 mmol) and TFA (0.10 mmol) in the solvent (1.0 mL). Stir for 10 mins at Room Temperature to form the active salt species.
- Temperature Equilibration: Place the reaction vessel in a cryostat set to  $-40^{\circ}\text{C}$ . Allow the solvent to equilibrate for at least 15 minutes. Do not add substrates until the solvent is at the target temperature.
- Substrate Addition: Add the electrophile (Enone, 0.5 mmol). Wait 5 minutes. Then add the nucleophile (0.75 mmol) slowly to prevent a localized exotherm.
- Monitoring: Stir at  $-40^{\circ}\text{C}$ . Monitor via TLC.
  - Self-Validation: If the reaction is  $<10\%$  complete after 4 hours, raise T to  $-20^{\circ}\text{C}$ .
- Quench: Quench cold with 1N HCl. Extract and analyze via Chiral HPLC.

## Data Reference: Temperature vs. Selectivity

The following table summarizes the effect of temperature on the Michael addition of nitromethane to chalcones using a 9-epi-cinchonidine thiourea derivative (Literature aggregate data).

Temperature (°C)	Time (h)	Yield (%)	ee (%)	Dominant Control Factor
25 (RT)	12	95	78	Mixed (Entropy significant)
0	18	92	86	Transitioning
-20	24	90	92	Enthalpic (Optimal)
-40	48	82	95	Enthalpic (Rate limited)
-78	96	35	96	Kinetic Trap (Too slow)

Note: Data represents a generalized trend for Cinchona-thiourea catalyzed Michael additions [1, 2].

## Mechanistic Insight: The "Dual Activation" Model

To understand why cooling works, one must visualize the transition state. The 9-epi-cinchonidine scaffold (often derivatized with a thiourea/squaramide at C9) operates via Bifunctional Catalysis.

- H-Bonding (Enthalpy): The thiourea moiety donates H-bonds to the electrophile (lowering LUMO). This is a highly ordered, directional interaction.
- Nucleophilic Activation: The quinuclidine nitrogen activates the nucleophile (raising HOMO).

At high temperatures, the vibrational energy disrupts the precise H-bond network, allowing the substrate to "slip" into the wrong face. At low temperatures, this "lock-and-key" fit is rigidified.

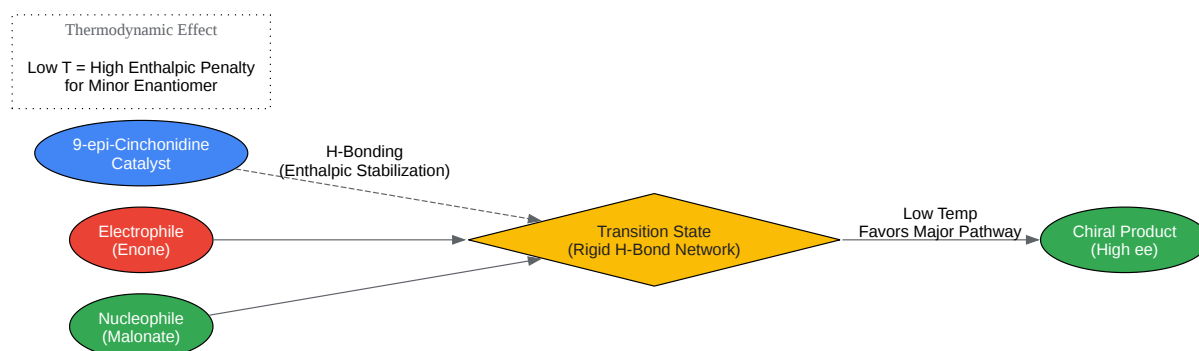

[Click to download full resolution via product page](#)

Caption: Bifunctional activation mode where temperature reduction stabilizes the H-bond network.

## References

- Cinchona Alkaloids in Asymmetric Catalysis. Princeton University, Macmillan Group. (2003). [6][7] Retrieved from 7
- Recent applications of Cinchona alkaloid-based catalysts in asymmetric addition reactions. Dove Medical Press. (2016). [5] Retrieved from 2
- Preparation and confinement effect of a heterogeneous 9-amino-9-deoxy-epi-cinchonidine organocatalyst. PubMed. (2012). [3][6][8] Retrieved from 8
- Plausible Pnicogen Bonding of epi-Cinchonidine as a Chiral Scaffold in Catalysis. Frontiers in Chemistry. (2021). [6] Retrieved from 6

### Need Custom Synthesis?

BenchChem offers custom synthesis for rare earth carbides and specific isotopic labeling.

Email: [info@benchchem.com](mailto:info@benchchem.com) or [Request Quote Online](#).

## Sources

- [1. Mechanism and Selectivity of Cinchona Alkaloid Catalyzed \[1,3\]-Shifts of Allylic Trichloroacetimidates - PMC \[pmc.ncbi.nlm.nih.gov\]](#)
- [2. dovepress.com \[dovepress.com\]](#)
- [3. html.rhhz.net \[html.rhhz.net\]](#)
- [4. moodle2.units.it \[moodle2.units.it\]](#)
- [5. researchgate.net \[researchgate.net\]](#)
- [6. Frontiers | Plausible Pnictogen Bonding of epi-Cinchonidine as a Chiral Scaffold in Catalysis \[frontiersin.org\]](#)
- [7. macmillan.princeton.edu \[macmillan.princeton.edu\]](#)
- [8. Preparation and confinement effect of a heterogeneous 9-amino-9-deoxy-epi-cinchonidine organocatalyst for asymmetric aldol addition in aqueous medium - PubMed \[pubmed.ncbi.nlm.nih.gov\]](#)
- To cite this document: BenchChem. [Technical Support Center: Epicinchonidine Stereoselectivity Optimization]. BenchChem, [2026]. [Online PDF]. Available at: [\[https://www.benchchem.com/product/b123159#effect-of-temperature-on-epicinchonidine-stereoselectivity\]](https://www.benchchem.com/product/b123159#effect-of-temperature-on-epicinchonidine-stereoselectivity)

---

### Disclaimer & Data Validity:

The information provided in this document is for Research Use Only (RUO) and is strictly not intended for diagnostic or therapeutic procedures. While BenchChem strives to provide accurate protocols, we make no warranties, express or implied, regarding the fitness of this product for every specific experimental setup.

**Technical Support:** The protocols provided are for reference purposes. Unsure if this reagent suits your experiment? [[Contact our Ph.D. Support Team for a compatibility check](#)]

**Need Industrial/Bulk Grade?** [Request Custom Synthesis Quote](#)

## BenchChem

Our mission is to be the trusted global source of essential and advanced chemicals, empowering scientists and researchers to drive progress in science and industry.

### Contact

Address: 3281 E Guasti Rd  
Ontario, CA 91761, United States  
Phone: (601) 213-4426  
Email: [info@benchchem.com](mailto:info@benchchem.com)