

# Technical Support Center: Ceric Ammonium Nitrate (CAN) Reaction Work-up

**Author:** BenchChem Technical Support Team. **Date:** May 2026

## Compound of Interest

Compound Name: *Azanium;cerium(4+);hexanitrate*

CAS No.: *16774-21-3*

Cat. No.: *B123368*

[Get Quote](#)

This technical support center provides troubleshooting guides and frequently asked questions (FAQs) for researchers, scientists, and drug development professionals encountering issues during the work-up of reactions involving Ceric Ammonium Nitrate (CAN).

## Troubleshooting Guide

This guide addresses specific problems that may arise during the work-up of CAN-mediated reactions.

Problem	Potential Cause(s)	Troubleshooting Steps
Persistent Orange/Yellow Color in Organic Layer	Incomplete quenching of Ce(IV).	<ul style="list-style-type: none"> <li>- Add additional saturated aqueous sodium bisulfite or sodium sulfite solution portion-wise until the color dissipates.</li> <li>- Stir the biphasic mixture vigorously for an extended period (15-30 minutes) to ensure complete reaction.</li> </ul>
Formation of an Emulsion	<ul style="list-style-type: none"> <li>- High concentration of cerium salts.</li> <li>- Presence of fine particulate matter.</li> </ul>	<ul style="list-style-type: none"> <li>- Add a small amount of brine (saturated aq. NaCl) to the separatory funnel and gently swirl.</li> <li>- If the emulsion persists, filter the entire mixture through a pad of Celite®. Wash the Celite® with the organic solvent used for extraction.</li> </ul>
Precipitate Formation at the Interface	Formation of insoluble cerium salts.	<ul style="list-style-type: none"> <li>- Add dilute acid (e.g., 1M HCl) to help dissolve the salts. Be cautious if your product is acid-sensitive.</li> <li>- Filter the entire mixture through Celite® as you would for an emulsion.</li> </ul>
Low Product Yield	<ul style="list-style-type: none"> <li>- Product is partially soluble in the aqueous layer.</li> <li>- Incomplete extraction.</li> </ul>	<ul style="list-style-type: none"> <li>- Perform multiple extractions (3-4 times) with the organic solvent.</li> <li>- "Salt out" the product from the aqueous layer by saturating it with NaCl before extraction.</li> <li>- Check the pH of the aqueous layer; adjust if necessary to ensure the product is in a neutral, less water-soluble form.</li> </ul>
Product Degradation	The product may be sensitive to the acidic conditions of the	<ul style="list-style-type: none"> <li>- Neutralize the reaction mixture with a mild base like</li> </ul>

CAN reaction or the work-up. sodium bicarbonate solution before extraction. - Minimize the time the product is in contact with acidic or basic aqueous solutions.

---

## Frequently Asked Questions (FAQs)

Q1: How do I properly quench a reaction involving Ceric Ammonium Nitrate?

A1: The orange-red color of the Ce(IV) complex should dissipate upon quenching, indicating its reduction to the colorless Ce(III) state.<sup>[1]</sup> A common and effective method is to add a saturated aqueous solution of a reducing agent like sodium bisulfite ( $\text{NaHSO}_3$ ) or sodium sulfite ( $\text{Na}_2\text{SO}_3$ ) until the organic layer becomes colorless.

Q2: What is the standard liquid-liquid extraction procedure after quenching a CAN reaction?

A2: After quenching, the typical procedure involves dilution with water and extraction with an organic solvent such as ethyl acetate or dichloromethane. The general steps are:

- Pour the reaction mixture into a separatory funnel.
- Add water and the chosen organic solvent.
- Shake the funnel, venting frequently to release any pressure.
- Allow the layers to separate.
- Drain the aqueous layer.
- Wash the organic layer sequentially with water and then brine to remove residual water-soluble impurities and inorganic salts.<sup>[2][3]</sup>
- Dry the organic layer over an anhydrous drying agent (e.g.,  $\text{Na}_2\text{SO}_4$  or  $\text{MgSO}_4$ ).
- Filter or decant the solvent to remove the drying agent.
- Concentrate the organic solvent under reduced pressure to obtain the crude product.

Q3: My product seems to be stuck in the aqueous layer. How can I improve its extraction?

A3: If your product has some water solubility, you can enhance its partitioning into the organic layer by:

- Increasing the number of extractions: Perform at least three to four extractions with your organic solvent.
- "Salting out": Add a significant amount of sodium chloride to the aqueous layer to decrease the solubility of your organic product in it.[2]

Q4: I see a solid precipitate forming during my work-up. What is it and what should I do?

A4: The precipitate is likely insoluble cerium salts. To handle this, you can either try to dissolve them by adding a small amount of dilute acid (if your product is stable) or physically remove them by filtering the entire biphasic mixture through a pad of Celite®.

Q5: Can residual cerium ions from the work-up interfere with downstream biological assays?

A5: Yes, trace amounts of cerium ions can potentially interfere with biological assays. Cerium ions, being redox-active, might interfere with assays that rely on redox chemistry.[4][5] They can also potentially disrupt signaling pathways that are sensitive to metal ions, such as those involving calcium signaling.[6][7] If your downstream application is sensitive to metal ions, it is crucial to ensure the complete removal of cerium.

## Experimental Protocols

### Protocol 1: Standard Quenching and Extraction of a CAN Reaction

- Quenching: Slowly add a saturated aqueous solution of sodium bisulfite to the reaction mixture with vigorous stirring. Continue the addition until the orange color of the Ce(IV) complex has completely disappeared, and the solution becomes a pale yellow or colorless.
- Dilution: Add deionized water to the quenched reaction mixture to dissolve the inorganic salts.

- **Extraction:** Transfer the mixture to a separatory funnel and extract the product with ethyl acetate (3 x 50 mL for a 100 mL reaction volume).
- **Washing:** Combine the organic extracts and wash sequentially with water (2 x 50 mL) and brine (1 x 50 mL).
- **Drying and Concentration:** Dry the organic layer over anhydrous sodium sulfate, filter, and concentrate under reduced pressure to yield the crude product.

## Visualizations

### Experimental Workflow for CAN Reaction Work-up

## Workflow for Ceric Ammonium Nitrate Reaction Work-up

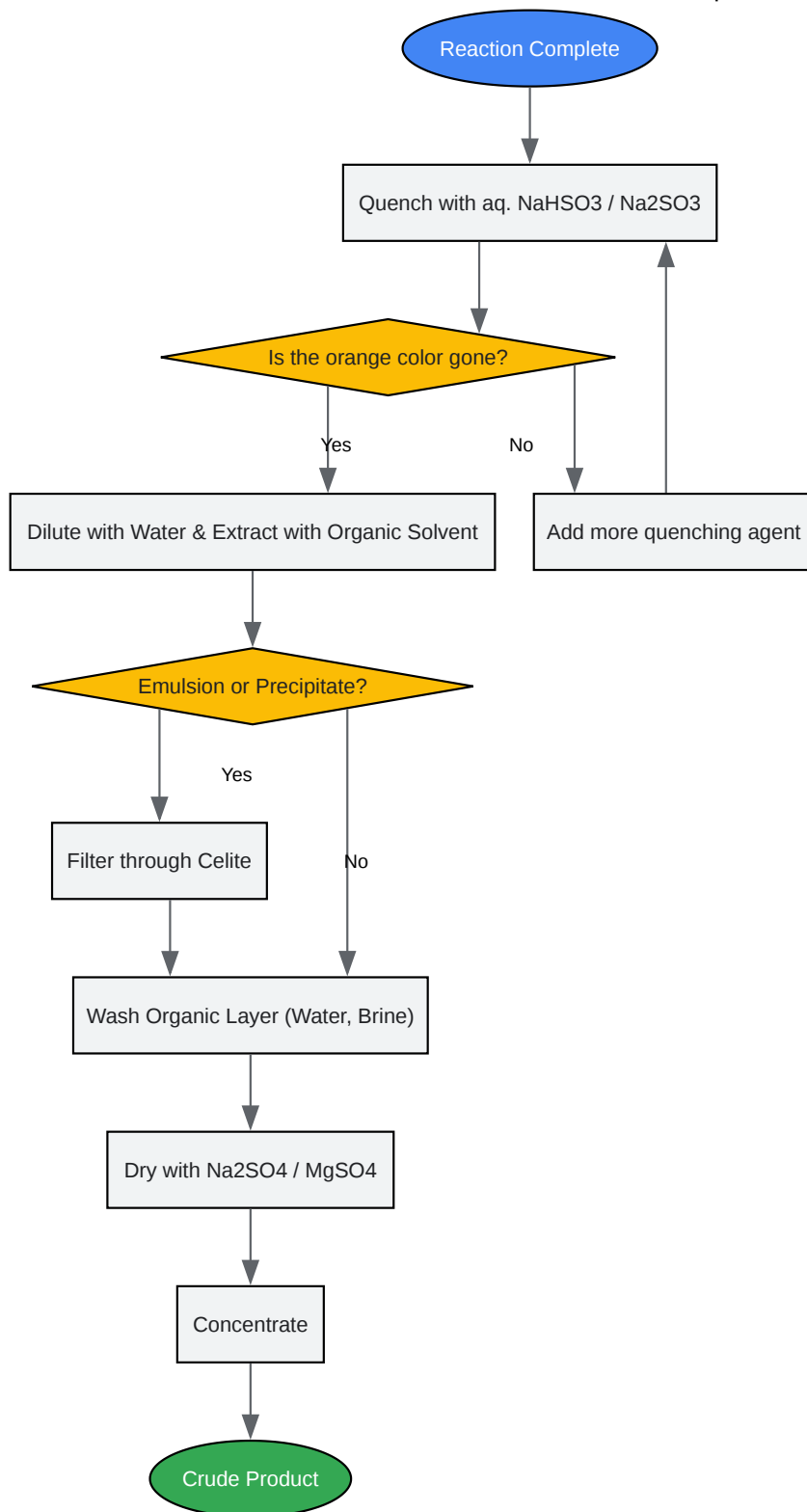

Potential Interference of Residual Ce<sup>3+</sup>/Ce<sup>4+</sup> in a Gq-PLC Signaling Pathway

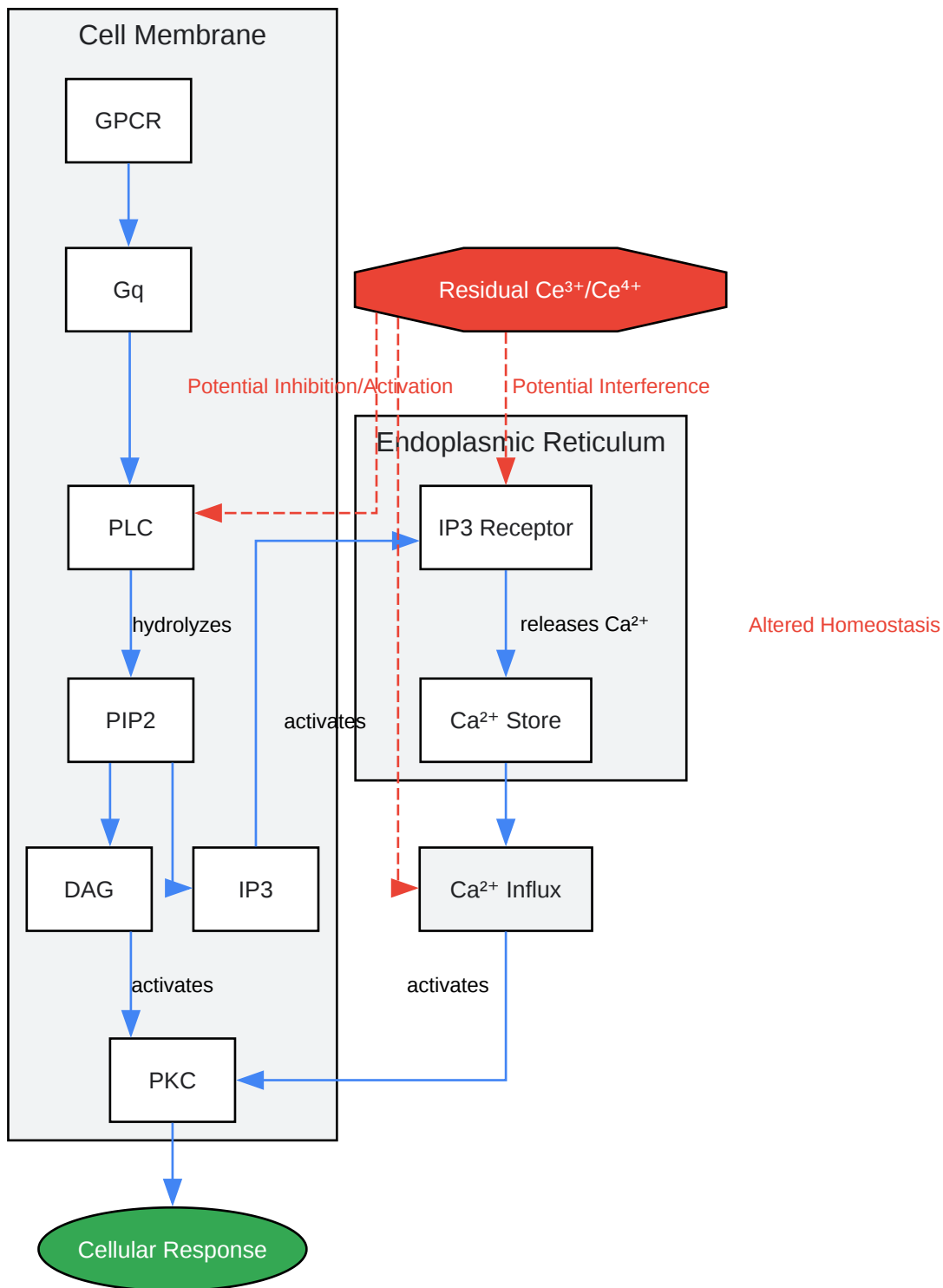

[Click to download full resolution via product page](#)

### Need Custom Synthesis?

BenchChem offers custom synthesis for rare earth carbides and specific isotopic labeling.

Email: [info@benchchem.com](mailto:info@benchchem.com) or [Request Quote Online](#).

## References

- [1. Ceric ammonium nitrate - Wikipedia \[en.wikipedia.org\]](#)
- [2. chem.libretexts.org \[chem.libretexts.org\]](#)
- [3. ocw.mit.edu \[ocw.mit.edu\]](#)
- [4. researchgate.net \[researchgate.net\]](#)
- [5. A Complete In Vitro Toxicological Assessment of the Biological Effects of Cerium Oxide Nanoparticles: From Acute Toxicity to Multi-Dose Subchronic Cytotoxicity Study - PMC \[pmc.ncbi.nlm.nih.gov\]](#)
- [6. Cell membrane disruption stimulates cAMP and Ca<sup>2+</sup> signaling to potentiate cell membrane resealing in neighboring cells - PMC \[pmc.ncbi.nlm.nih.gov\]](#)
- [7. researchgate.net \[researchgate.net\]](#)
- To cite this document: BenchChem. [Technical Support Center: Ceric Ammonium Nitrate (CAN) Reaction Work-up]. BenchChem, [2026]. [Online PDF]. Available at: [\[https://www.benchchem.com/product/b123368/docs#technical-support-center-ceric-ammonium-nitrate-can-reaction-work-up\]](https://www.benchchem.com/product/b123368/docs#technical-support-center-ceric-ammonium-nitrate-can-reaction-work-up)

---

### Disclaimer & Data Validity:

The information provided in this document is for Research Use Only (RUO) and is strictly not intended for diagnostic or therapeutic procedures. While BenchChem strives to provide accurate protocols, we make no warranties, express or implied, regarding the fitness of this product for every specific experimental setup.

**Technical Support:** The protocols provided are for reference purposes. Unsure if this reagent suits your experiment?

**Need Industrial/Bulk Grade?** [Request Custom Synthesis Quote](#)

# BenchChem

Our mission is to be the trusted global source of essential and advanced chemicals, empowering scientists and researchers to drive progress in science and industry.

## Contact

Address: 3281 E Guasti Rd

Ontario, CA 91761, United States

Phone: (601) 213-4426

Email: [info@benchchem.com](mailto:info@benchchem.com)

[Contact our Ph.D. Support Team for a compatibility check](#)