

Halogenated Quinoline-3-Carboxylates: A Comparative Guide to Structure-Activity Relationships

Author: BenchChem Technical Support Team. **Date:** May 2026

Compound of Interest

| | |
|----------------|---|
| Compound Name: | <i>Ethyl 4-chloro-6,8-difluoroquinoline-3-carboxylate</i> |
| CAS No.: | 150258-20-1 |
| Cat. No.: | B123628 |

[Get Quote](#)

For Researchers, Scientists, and Drug Development Professionals

The quinoline scaffold is a privileged structure in medicinal chemistry, with its derivatives exhibiting a wide range of biological activities. Among these, halogenated quinoline-3-carboxylates have emerged as a promising class of compounds with significant potential in the development of novel anticancer and antimicrobial agents. This guide provides a comparative analysis of the structure-activity relationships (SAR) of these compounds, supported by experimental data, to aid in the rational design of more potent and selective therapeutic agents.

Anticancer Activity: Targeting Proliferation and Angiogenesis

Halogenated quinoline-3-carboxylates have demonstrated notable cytotoxic activity against a variety of cancer cell lines. The nature and position of the halogen substituent on the quinoline ring play a crucial role in determining their potency and selectivity.

Comparative Anticancer Potency

The following table summarizes the in vitro anticancer activity of representative halogenated quinoline-3-carboxylates against various human cancer cell lines, presented as IC50 values (the concentration required to inhibit the growth of 50% of cancer cells).

| Compound ID | R1 (Position 6) | R2 (Position 2) | Cancer Cell Line | IC50 (µM) | Reference |
|-------------|-----------------|---------------------------|-------------------------------|-----------------|-----------|
| 1a | -F | 3'-fluorophenyl | MDA-MB-468 | 4.0 | [1] |
| 1b | -F | 4'-fluorophenyl | MDA-MB-468 | 5.0 | [1] |
| 1c | -Br | 3'-fluorophenyl | MDA-MB-468 | - | [1] |
| 2a | -Cl | 4-hydroxy-3-methoxyphenyl | MCF-7 | >100 | [2] |
| 2b | -Cl | 4-hydroxy-3-methoxyphenyl | K-562 | 51.1% apoptosis | [2] |
| 3a | -Br | - | A549, HeLa, HT29, Hep3B, MCF7 | 2-50 | [3] |
| 3b | di-Br (6,8) | - | A549, HeLa, HT29, Hep3B, MCF7 | 2-50 | [3] |
| 3c | di-Br (5,7) | -OH (at 8) | A549, HeLa, HT29, Hep3B, MCF7 | 2-50 | [3] |

Structure-Activity Relationship Insights:

- **Fluorine Substitution:** The presence of fluorine atoms on the quinoline ring and its substituents has been shown to be critical for anticancer activity. For instance, compounds 1a and 1b, both containing a fluorine at the 6-position and a fluorinated phenyl group at the 2-position, exhibit potent activity against the triple-negative breast cancer cell line MDA-MB-468.[1] The position of the fluorine on the phenyl ring also influences potency, with the meta-position (1a) being slightly more active than the para-position (1b).[1]
- **Chloro and Bromo Substitution:** Chloro and bromo substitutions also contribute to the anticancer profile. Compound 2b, a 6-chloroquinoline-4-carboxylic acid derivative, induced significant apoptosis in the K-562 leukemia cell line.[2] Brominated quinolines, such as 3a, 3b, and 3c, have demonstrated broad-spectrum antiproliferative activity against a panel of cancer cell lines with IC50 values in the low micromolar range.[3]
- **Other Substituents:** The presence of other functional groups, such as an ester group, can be crucial for activity. Hydrolysis of the ester group in some fluorinated quinoline analogues led to a loss of activity against triple-negative breast cancer cells, suggesting the importance of this moiety.[1]

Mechanisms of Anticancer Action

Halogenated quinoline-3-carboxylates exert their anticancer effects through various mechanisms, primarily by interfering with key signaling pathways involved in cancer cell proliferation and survival.

Inhibition of EGFR/VEGFR Signaling:

Many quinoline derivatives act as inhibitors of receptor tyrosine kinases such as the Epidermal Growth Factor Receptor (EGFR) and Vascular Endothelial Growth Factor Receptor (VEGFR). [4] These receptors are often overexpressed in cancer cells and play a central role in promoting cell growth, proliferation, and angiogenesis. By blocking these signaling pathways, halogenated quinoline-3-carboxylates can effectively halt tumor progression.

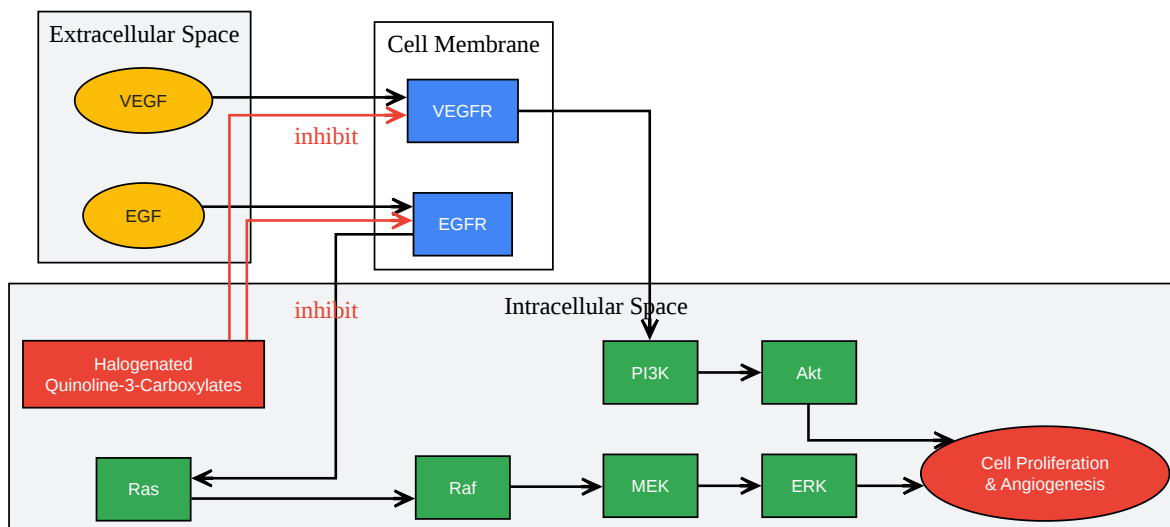

[Click to download full resolution via product page](#)

Caption: Inhibition of EGFR/VEGFR signaling by halogenated quinoline-3-carboxylates.

Inhibition of Tubulin Polymerization:

Another important mechanism of action for some quinoline derivatives is the inhibition of tubulin polymerization.[5] Microtubules, which are polymers of tubulin, are essential components of the cytoskeleton and are crucial for cell division. By disrupting microtubule dynamics, these compounds can arrest the cell cycle in the G2/M phase, leading to apoptosis.[5]

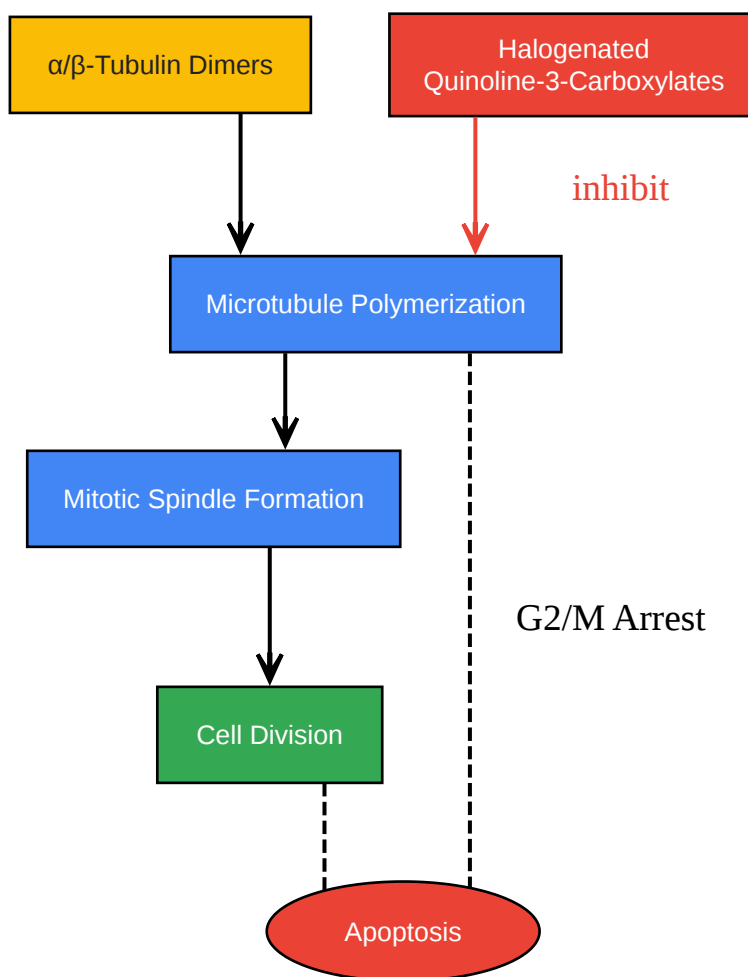

[Click to download full resolution via product page](#)

Caption: Inhibition of tubulin polymerization by halogenated quinoline-3-carboxylates.

Antimicrobial Activity: A Renewed Hope Against Resistance

Halogenated quinoline-3-carboxylates, particularly the fluoroquinolones, are a well-established class of antibacterial agents. Their mechanism of action involves the inhibition of bacterial DNA gyrase and topoisomerase IV, enzymes essential for DNA replication and repair.^{[2][6][7]}

Comparative Antimicrobial Potency

The minimum inhibitory concentration (MIC) is a key measure of an antimicrobial agent's potency. The following table presents the MIC values of various halogenated quinoline

derivatives against a panel of pathogenic bacteria.

| Compound ID | R1 (Position 2) | R2 (Position on Phenyl) | Bacterial Strain | MIC ($\mu\text{g/mL}$) | Reference |
|-------------|--------------------|-------------------------|------------------|--------------------------|-----------|
| 4a | -CF ₃ | p-CH ₃ | MRSA | 3.0 | [8] |
| 4b | -CF ₃ | p-CF ₃ | MRSA | 0.75 | [8] |
| 4c | -CF ₃ | 3-Cl, 4-F | MRSA | 3.0 | [8] |
| 5a | p-isopropyl phenyl | 3-Cl, 4-F | MRSA | 1.5 | [8] |
| 6a | - | - | S. epidermidis | 0.59 (μM) | [9] |
| 7a | - | - | S. aureus | 0.12 | [10] |
| 7b | - | - | S. pyogenes | 8 | [10] |
| 7c | - | - | S. typhi | 0.12 | [10] |
| 7d | - | - | P. aeruginosa | >1024 | [10] |
| 7e | - | - | E. coli | 0.12 | [10] |

Structure-Activity Relationship Insights:

- Fluorine at C6: The presence of a fluorine atom at the C-6 position is a common feature in many potent fluoroquinolone antibiotics and generally enhances antibacterial activity.[11]
- Substituents at C7: The nature of the substituent at the C-7 position significantly influences the spectrum and potency of activity.[11] Heterocyclic substitutions, such as a piperazinyl ring, often broaden the spectrum of activity, particularly against Gram-negative bacteria.[11]
- Halogenation on Phenyl Ring: Halogenation on a phenyl substituent at the 2-position can also modulate activity. For instance, a para-trifluoromethyl group (4b) on the phenyl ring led to enhanced activity against MRSA compared to a para-methyl group (4a).[8]

- Other Halogenations: The presence of halogens at other positions can also be beneficial. A 3-chloro-4-fluoro substitution on the phenyl ring (4c and 5a) resulted in potent anti-MRSA activity.[8]

Mechanism of Antimicrobial Action

The primary mechanism of action for fluoroquinolones is the inhibition of bacterial DNA gyrase and topoisomerase IV. These enzymes are crucial for maintaining the proper topology of DNA during replication. By forming a stable complex with the enzyme and DNA, fluoroquinolones trap the enzyme in a state where it has cleaved the DNA but cannot reseal it, leading to the accumulation of double-strand breaks and ultimately cell death.[2][6][7]

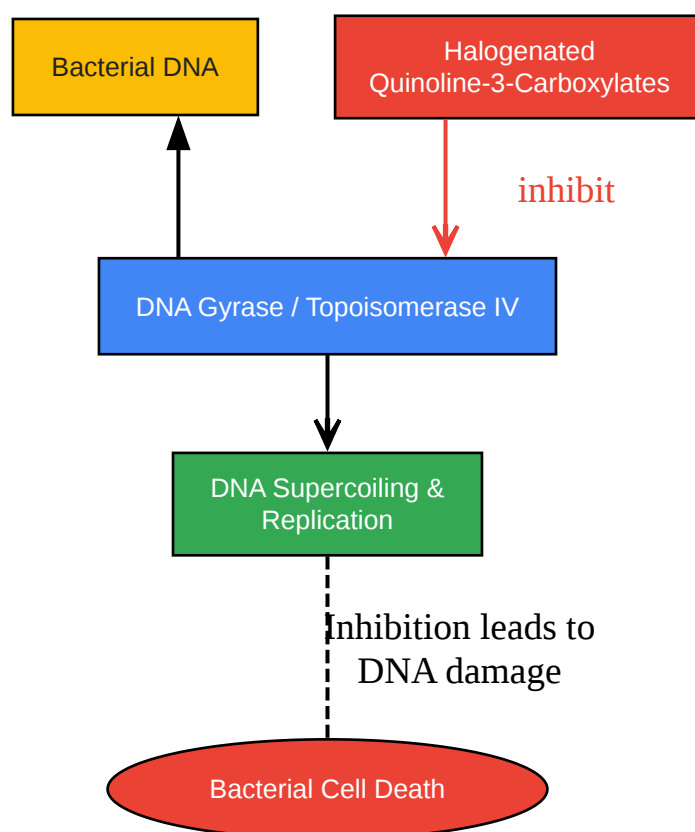

[Click to download full resolution via product page](#)

Caption: Inhibition of DNA gyrase and topoisomerase IV by halogenated quinoline-3-carboxylates.

Experimental Protocols

In Vitro Anticancer Activity: MTT Assay

The MTT (3-(4,5-dimethylthiazol-2-yl)-2,5-diphenyltetrazolium bromide) assay is a colorimetric assay for assessing cell metabolic activity and is widely used to measure the cytotoxic effects of potential anticancer drugs.[\[12\]](#)

Procedure:

- **Cell Seeding:** Cancer cells are seeded in 96-well plates at a density of 5,000-10,000 cells per well and incubated for 24 hours to allow for cell attachment.[\[12\]](#)
- **Compound Treatment:** The cells are then treated with serial dilutions of the test compounds. A vehicle control (e.g., DMSO) and a positive control (a known anticancer drug) are included.[\[12\]](#)
- **Incubation:** The plates are incubated for 48-72 hours at 37°C in a humidified atmosphere with 5% CO₂.[\[12\]](#)
- **MTT Addition:** After incubation, MTT solution is added to each well, and the plates are incubated for an additional 4 hours. Viable cells with active metabolism convert the yellow MTT into a purple formazan product.[\[12\]](#)
- **Solubilization:** The medium is removed, and a solubilization buffer is added to dissolve the formazan crystals.[\[12\]](#)
- **Absorbance Measurement:** The absorbance is measured at a wavelength of 570 nm using a microplate reader.[\[12\]](#)
- **IC₅₀ Calculation:** The percentage of cell viability is calculated relative to the vehicle control, and the IC₅₀ value is determined.[\[12\]](#)

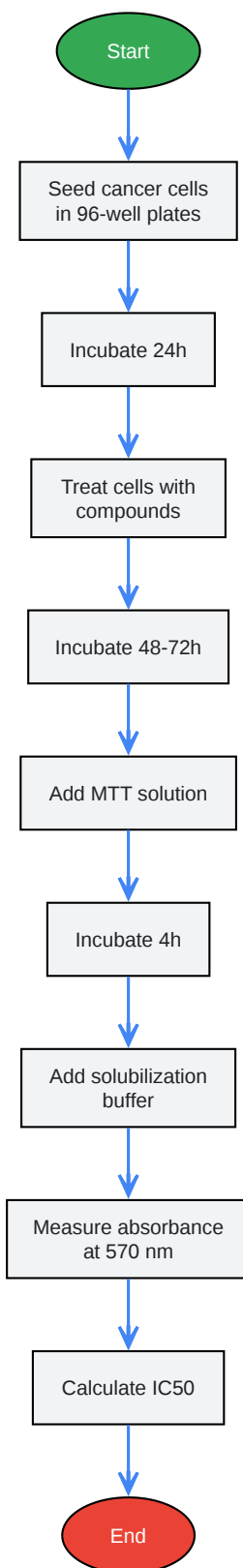

[Click to download full resolution via product page](#)

Caption: Experimental workflow for the MTT assay.

In Vitro Antimicrobial Activity: Broth Microdilution Method

The broth microdilution method is a standard laboratory procedure used to determine the minimum inhibitory concentration (MIC) of an antimicrobial agent against a specific microorganism.[10][13]

Procedure:

- **Inoculum Preparation:** A standardized suspension of the test microorganism is prepared in a suitable broth (e.g., Mueller-Hinton Broth for bacteria) to a concentration of approximately 5×10^5 colony-forming units (CFU)/mL.[13]
- **Compound Dilution:** Serial two-fold dilutions of the test compound are prepared in the wells of a 96-well microtiter plate containing the broth.[13]
- **Inoculation:** Each well is inoculated with the standardized microbial suspension. A positive control (broth with inoculum, no compound) and a negative control (broth only) are included. [13]
- **Incubation:** The plate is incubated under appropriate conditions (e.g., 37°C for 18-24 hours for most bacteria).[13]
- **MIC Determination:** The MIC is determined as the lowest concentration of the compound that completely inhibits visible growth of the microorganism.[13]

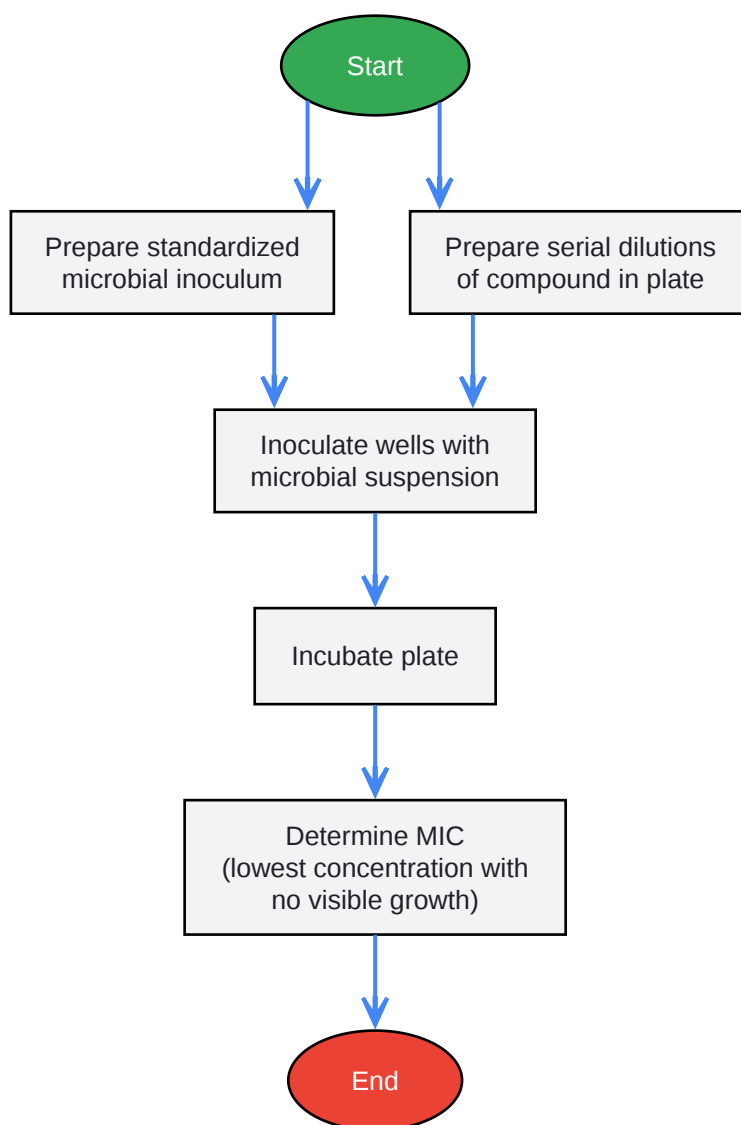

[Click to download full resolution via product page](#)

Caption: Experimental workflow for the broth microdilution susceptibility test.

Need Custom Synthesis?

BenchChem offers custom synthesis for rare earth carbides and specific isotopic labeling.

Email: info@benchchem.com or [Request Quote Online](#).

References

- 1. [researchgate.net](https://www.researchgate.net) [[researchgate.net](https://www.researchgate.net)]

- 2. Exploration of quinolone and quinoline derivatives as potential anticancer agents - PMC [[pmc.ncbi.nlm.nih.gov](https://pubmed.ncbi.nlm.nih.gov)]
- 3. researchgate.net [researchgate.net]
- 4. researchgate.net [researchgate.net]
- 5. Antineoplastic - Wikipedia [en.wikipedia.org]
- 6. researchgate.net [researchgate.net]
- 7. mdpi.com [mdpi.com]
- 8. Facilely Accessible Quinoline Derivatives as Potent Antibacterial Agents - PMC [[pmc.ncbi.nlm.nih.gov](https://pubmed.ncbi.nlm.nih.gov)]
- 9. Halogenated quinolines bearing polar functionality at the 2-position: Identification of new antibacterial agents with enhanced activity against Staphylococcus epidermidis - PubMed [pubmed.ncbi.nlm.nih.gov]
- 10. Quinoline derivatives volunteering against antimicrobial resistance: rational approaches, design strategies, structure activity relationship and mechanistic insights - PMC [[pmc.ncbi.nlm.nih.gov](https://pubmed.ncbi.nlm.nih.gov)]
- 11. youtube.com [youtube.com]
- 12. A comprehensive pathway map of epidermal growth factor receptor signaling - PMC [[pmc.ncbi.nlm.nih.gov](https://pubmed.ncbi.nlm.nih.gov)]
- 13. Structure-activity relationship of quinoline carboxylic acids. A new class of inhibitors of dihydroorotate dehydrogenase - PubMed [pubmed.ncbi.nlm.nih.gov]
- To cite this document: BenchChem. [Halogenated Quinoline-3-Carboxylates: A Comparative Guide to Structure-Activity Relationships]. BenchChem, [2026]. [Online PDF]. Available at: [<https://www.benchchem.com/product/b123628/docs#halogenated-quinoline-3-carboxylates-a-comparative-guide-to-structure-activity-relationships>]

Disclaimer & Data Validity:

The information provided in this document is for Research Use Only (RUO) and is strictly not intended for diagnostic or therapeutic procedures. While BenchChem strives to provide accurate protocols, we make no warranties, express or implied, regarding the fitness of this product for every specific experimental setup.

Technical Support: The protocols provided are for reference purposes. Unsure if this reagent suits your experiment?

Need Industrial/Bulk Grade? [Request Custom Synthesis Quote](#)

BenchChem

Our mission is to be the trusted global source of essential and advanced chemicals, empowering scientists and researchers to drive progress in science and industry.

Contact

Address: 3281 E Guasti Rd
Ontario, CA 91761, United States
Phone: (601) 213-4426
Email: info@benchchem.com

[Contact our Ph.D. Support Team for a compatibility check](#)