

optimizing collision energy for LPC 16:0-d3 precursor ion

Author: BenchChem Technical Support Team. **Date:** May 2026

Compound of Interest

Compound Name: *1-Palmitoyl-d3-2-hydroxy-sn-glycero-3-PC*

Cat. No.: *B12299465*

[Get Quote](#)

Technical Support Center: LPC 16:0-d3 MS/MS Optimization

Topic: Optimizing Collision Energy (CE) for LPC 16:0-d3 Precursor Ion Audience: Researchers, Scientists, and Drug Development Professionals Content ID: TS-LPC-OPT-001

Introduction: The "Why" Behind the Protocol

Welcome to the Technical Support Center. You are likely here because you are establishing a targeted lipidomics method or quantifying Lysophosphatidylcholine (LPC) 16:0 using its deuterated internal standard (IS), LPC 16:0-d3.

The Core Challenge: In electrospray ionization (ESI+), phosphocholine-containing lipids are notorious for their high ionization efficiency but also their susceptibility to in-source fragmentation. The goal of optimizing Collision Energy (CE) is not merely to find the point of highest intensity. It is to find the "Stability Plateau"—the CE range where the product ion signal is robust, reproducible, and resistant to minor fluctuations in instrument performance, while eliminating the precursor ion to prevent ghost peaks.

This guide treats the optimization process as a self-validating experiment.

Part 1: Pre-Optimization Verification (Critical Step)

Before touching the instrument, you must verify the isotopologue structure. "LPC 16:0-d3" is ambiguous. The position of the deuterium label dictates your transition.

Label Position	Precursor Ion ()	Product Ion (Fragment)	Note
Choline-d3 (Headgroup)	~499.4 m/z	187.1 m/z	Most Common IS. Shifts fragment mass to avoid crosstalk with native LPC.
Palmitoyl-d3 (Fatty Acid)	~499.4 m/z	184.1 m/z	Fragment is identical to native LPC. High risk of crosstalk/interference.

Note: This guide assumes the Choline-d3 configuration (Product 187.1), as it is the gold standard for quantification.

Part 2: The Optimization Workflow

Do not rely on literature values alone. Instrument geometry (Triple Quad vs. Q-TOF, varying collision cell gas pressures) necessitates empirical determination.

Diagram 1: The Optimization Logic Flow

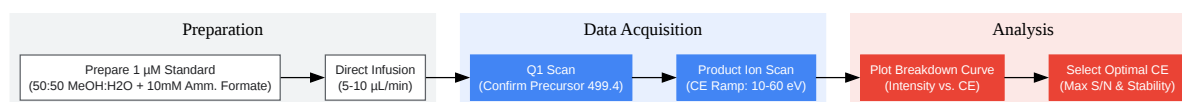

[Click to download full resolution via product page](#)

Caption: Logical workflow for empirically determining optimal collision energy (CE) via direct infusion.

Step-by-Step Protocol: The Breakdown Curve

- Preparation: Dilute your LPC 16:0-d3 standard to $\sim 1 \mu\text{M}$ (approx. 500 ng/mL) in your mobile phase starting solvent (typically 50:50 Methanol:Water with 10mM Ammonium Formate).
 - Why? Ammonium formate promotes the species. Pure solvent might yield sodium adducts, which do not fragment efficiently.
- Infusion: Connect via syringe pump directly to the source (flow rate 5–10 $\mu\text{L}/\text{min}$).
- Q1 Verification: Perform a Q1 scan. Ensure the parent ion (m/z 499.4) is the dominant peak.
 - Troubleshooting: If you see m/z 521.4, you have sodium contamination. Add trace formic acid (0.1%).^{[1][2]}
- Product Ion Scan (The Ramp):
 - Select precursor 499.4.
 - Set up a "Product Ion Scan" method.
 - Variable: Collision Energy (CE).^{[2][3]}
 - Range: Ramp from 10 eV to 60 eV in increments of 2-5 eV.
- Data Extraction: For each CE step, record the intensity of the m/z 187.1 fragment and the remaining precursor (m/z 499.4).

Part 3: Interpreting the Data (The Breakdown Curve)

You will generate a dataset similar to the theoretical example below.

Collision Energy (eV)	Precursor (499.4) Intensity	Product (187.1) Intensity	Status
10	1.5e7 (100%)	2.0e4 (<1%)	Under-fragmented
20	8.0e6 (53%)	6.5e6 (43%)	Rising
28	5.0e4 (<1%)	1.4e7 (100%)	Optimal (Max Signal)
35	0 (0%)	1.3e7 (92%)	Stable Plateau
50	0 (0%)	4.0e6 (28%)	Over-fragmented

The Scientist's Choice:

- Don't just pick the maximum (28 eV).
- Look at the range after the maximum (e.g., 30–35 eV).
- Reasoning: If you select the absolute peak (28 eV), a slight drift in gas pressure or electronics could drop you down the steep slope of the curve (20 eV), causing massive RSD (Relative Standard Deviation) issues.
- Recommendation: Choose a CE slightly on the higher side of the maximum (e.g., 30-32 eV) where the precursor is fully depleted, and the product signal is stable.

Diagram 2: Fragmentation Pathway & Logic

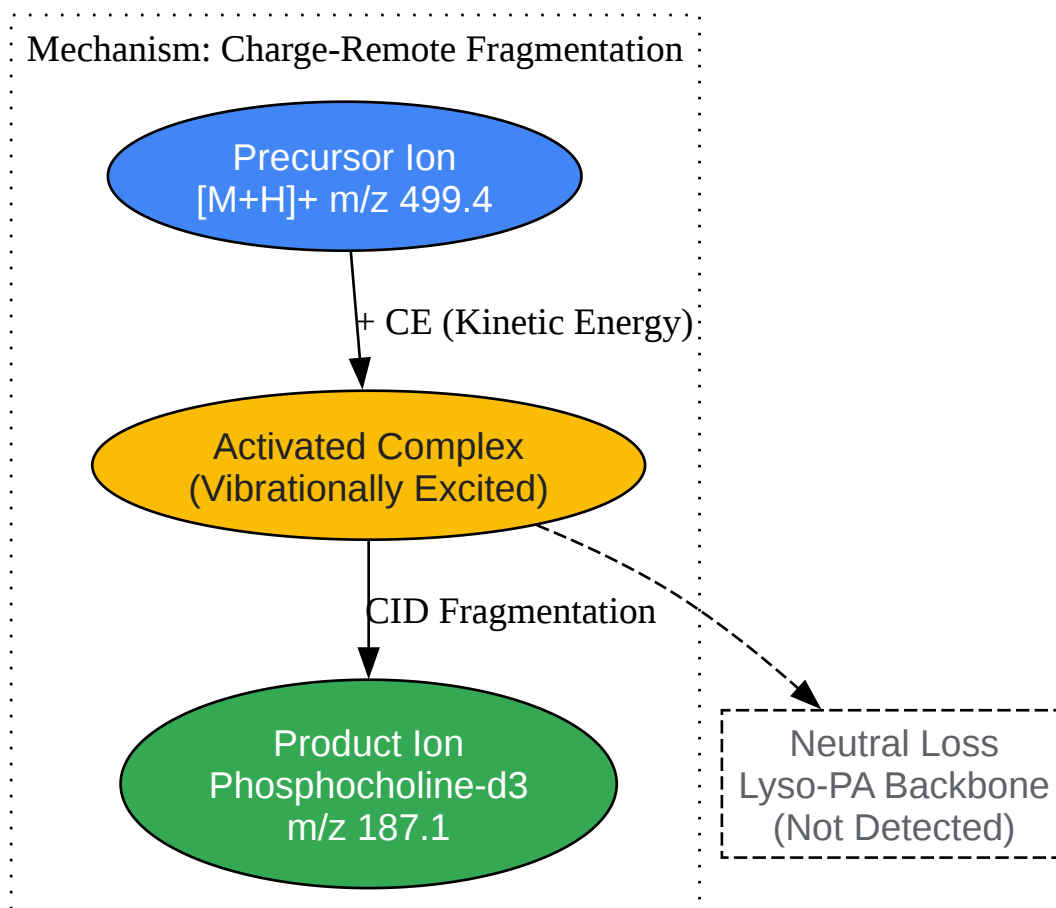

[Click to download full resolution via product page](#)

Caption: CID fragmentation pathway of LPC 16:0-d3 yielding the characteristic phosphocholine headgroup ion.

Part 4: Troubleshooting & FAQs

Q: My signal for m/z 187.1 is weak, but m/z 184.1 is huge. Why?

A: You are likely seeing "Crosstalk" or contamination.

- Check your standard: Did you accidentally mix native LPC 16:0 with the d3 standard?
- Check the label: If you bought "Palmitoyl-d3" LPC, the headgroup is unlabeled, so it naturally fragments to 184.1. You must switch to Choline-d3 labeled standard for specific detection.

- Check Isotopic Isolation: Ensure your Q1 isolation window is not too wide. If native LPC is present in high amounts (e.g., in plasma), the M+3 isotope of the native lipid (approx 0.5% abundance) can bleed into the d3 channel if resolution is poor.

Q: I see a strong peak at m/z 104.1. Is this relevant?

A: That is the choline ion (trimethylammonium-ethyl). It is a secondary fragment resulting from too much collision energy.

- Fix: Lower your CE. You are shattering the phosphocholine headgroup itself.

Q: Can I use the same CE for LPC 18:0-d3 or LPC 18:1-d7?

A: Generally, yes. The fragmentation of LPCs in positive mode is driven by the headgroup, which is identical across the class. The fatty acid chain length has minimal impact on the optimal CE for the headgroup fragment. However, verify with a quick spot-check (e.g., run the 30 eV vs 40 eV comparison).

Q: Why is my Precursor (499.4) drifting in mass?

A: This is rarely a mass drift and more likely an adduct shift.

- If you see 521.4, it is a Sodium adduct ($[M+Na]^+$).^[4]
- If you see 516.4, it is an Ammonium adduct ($[M+NH_4]^+$).^[4]
- Fix: Ensure your mobile phase has 5-10mM Ammonium Formate/Acetate. This forces the population into the protonated ($[M+H]^+$) or ammoniated forms, which are easier to fragment than sodiated ions.

References

- Lipid MAPS® Lipidomics Gateway. "LMSD: Lipid Structure Database - LPC 16:0." Lipid Maps. Available at: [\[Link\]](#)
- Avanti Polar Lipids. "16:0 LPC-d3 (deuteriated on choline methyls)." Avanti Polar Lipids.[\[5\]](#)[\[6\]](#)[\[7\]](#) Available at: [\[Link\]](#)
- Liebisch, G., et al. (2013). "High throughput quantification of cholesterol and cholesteryl ester by electrospray ionization tandem mass spectrometry (ESI-MS/MS)." *Biochimica et Biophysica Acta (BBA)*. Available at: [\[Link\]](#) (Demonstrates principles of CE optimization for lipid classes).

Need Custom Synthesis?

BenchChem offers custom synthesis for rare earth carbides and specific isotopic labeling.

Email: info@benchchem.com or [Request Quote Online](#).

Sources

- [1. repository.up.ac.za](https://repository.up.ac.za) [repository.up.ac.za]
- [2. escholarship.org](https://escholarship.org) [escholarship.org]
- [3. storage.googleapis.com](https://storage.googleapis.com) [storage.googleapis.com]
- [4. Development of a High Coverage Pseudotargeted Lipidomics Method Based on Ultra-High Performance Liquid Chromatography–Mass Spectrometry - PMC](https://pubmed.ncbi.nlm.nih.gov/24111111/) [[pmc.ncbi.nlm.nih.gov](https://pubmed.ncbi.nlm.nih.gov/24111111/)]
- [5. waters.com](https://www.waters.com) [[waters.com](https://www.waters.com)]
- [6. dovepress.com](https://www.dovepress.com) [[dovepress.com](https://www.dovepress.com)]
- [7. mdpi.com](https://www.mdpi.com) [[mdpi.com](https://www.mdpi.com)]
- To cite this document: BenchChem. [optimizing collision energy for LPC 16:0-d3 precursor ion]. BenchChem, [2026]. [Online PDF]. Available at: [\[https://www.benchchem.com/product/b12299465/docs#optimizing-collision-energy-for-lpc-16-0-d3-precursor-ion\]](https://www.benchchem.com/product/b12299465/docs#optimizing-collision-energy-for-lpc-16-0-d3-precursor-ion)

Disclaimer & Data Validity:

The information provided in this document is for Research Use Only (RUO) and is strictly not intended for diagnostic or therapeutic procedures. While BenchChem strives to provide accurate protocols, we make no warranties, express or implied, regarding the fitness of this product for every specific experimental setup.

Technical Support: The protocols provided are for reference purposes. Unsure if this reagent suits your experiment?

Need Industrial/Bulk Grade? [Request Custom Synthesis Quote](#)

BenchChem

Our mission is to be the trusted global source of essential and advanced chemicals, empowering scientists and researchers to drive progress in science and industry.

Contact

Address: 3281 E Guasti Rd
Ontario, CA 91761, United States
Phone: (601) 213-4426
Email: info@benchchem.com

[Contact our Ph.D. Support Team for a compatibility check](#)