

Technical Support Center: Imaging with FD-1080 Fluorophore

Author: BenchChem Technical Support Team. **Date:** April 2026

Compound of Interest

Compound Name: FD-1080
Cat. No.: B12296719

[Get Quote](#)

This technical support center provides troubleshooting guidance and frequently asked questions (FAQs) for researchers, scientists, and drug development professionals utilizing the **FD-1080** near-infrared (NIR) fluorophore in their imaging experiments.

Frequently Asked Questions (FAQs)

Q1: What is **FD-1080**?

A1: **FD-1080** is a small-molecule organic fluorophore with both excitation and emission spectra in the second near-infrared (NIR-II) window.^{[1][2]} It is designed for deep-tissue, high-resolution in vivo imaging due to reduced photon scattering and minimal tissue autofluorescence at these wavelengths.^{[3][4]}

Q2: What are the optimal excitation and emission wavelengths for **FD-1080**?

A2: The optimal excitation wavelength for **FD-1080** is 1064 nm, with its peak emission occurring at approximately 1080 nm.

Q3: What is the quantum yield of **FD-1080** and can it be improved?

A3: The quantum yield of **FD-1080** in ethanol is reported to be 0.31%. This can be significantly increased to 5.94% when complexed with fetal bovine serum (FBS).[5]

Q4: How should I prepare **FD-1080** for in vivo experiments?

A4: For in vivo imaging, **FD-1080** is often encapsulated with a carrier protein like fetal bovine serum (FBS) to form a complex. This enhances its stability and quantum yield. A common method involves mixing **FD-1080** with FBS for intravenous injection.

Troubleshooting Guide

Issue 1: Low Signal-to-Noise Ratio (SNR)

Symptoms:

- The fluorescent signal from the region of interest is weak and difficult to distinguish from the background.
- Images appear grainy or noisy.

Possible Causes & Solutions:

Cause	Solution
Suboptimal Fluorophore Concentration	Titrate the concentration of the FD-1080-FBS complex to find the optimal balance between signal and background.
Low Quantum Yield	Ensure proper complexation with FBS to maximize the quantum yield of FD-1080.[5] Consider using heavy water (D2O) as a solvent for the injectate, as it can enhance the fluorescence signal in the NIR-II region.[4]
Inadequate Laser Power	Increase the laser power at the 1064 nm excitation wavelength. Be cautious to avoid phototoxicity and photobleaching.
Detector Settings Not Optimized	Adjust the gain and exposure time of your NIR camera or detector. Increasing exposure time can improve signal but may also increase noise. Use frame averaging to reduce random noise.
High Background Fluorescence	Minimize ambient light in the imaging room. Use appropriate emission filters to block scattered excitation light and autofluorescence.

Issue 2: High Background Signal

Symptoms:

- The entire image appears bright, obscuring the specific signal from the **FD-1080** fluorophore.
- Poor contrast between the target and surrounding tissue.

Possible Causes & Solutions:

Cause	Solution
Autofluorescence from Tissue	While minimized in the NIR-II window, some autofluorescence can still occur. Ensure you are using a narrow bandpass emission filter centered around 1080 nm.
Scattered Excitation Light	Use high-quality, steep-edged long-pass and band-pass filters to effectively block scattered excitation light from reaching the detector.
Non-specific Accumulation of FD-1080	Optimize the dose and injection protocol to minimize non-specific binding of the FD-1080-FBS complex. Allow sufficient time for the probe to accumulate in the target tissue and clear from non-target areas.
Ambient Light Contamination	Ensure the imaging system is in a light-tight enclosure or a completely dark room.

Issue 3: Photobleaching

Symptoms:

- The fluorescence signal intensity decreases over time during continuous imaging.

Possible Causes & Solutions:

Cause	Solution
Excessive Laser Power	Reduce the excitation laser power to the minimum level required for adequate signal.
Prolonged Exposure	Minimize the duration of continuous laser exposure. Use intermittent imaging or reduce the frame rate.
Oxygen Presence	The presence of singlet oxygen can accelerate photobleaching. While difficult to control in vivo, being aware of this mechanism is important.

Experimental Protocols

Protocol 1: Preparation of FD-1080-FBS Complex for In Vivo Imaging

Objective: To prepare a stable and highly fluorescent **FD-1080** complex for intravenous injection.

Materials:

- **FD-1080** stock solution (e.g., 1 mg/mL in DMSO)
- Fetal Bovine Serum (FBS)
- Phosphate-Buffered Saline (PBS), sterile
- 0.22 μm syringe filter

Procedure:

- Vortex the **FD-1080** stock solution.
- In a sterile microcentrifuge tube, add the desired amount of **FD-1080** stock solution to FBS. A common ratio is 1:10 (v/v) **FD-1080** to FBS.
- Incubate the mixture at room temperature for 30 minutes, protected from light.
- Dilute the **FD-1080**-FBS complex with sterile PBS to the final desired injection concentration.
- Filter the final solution through a 0.22 μm syringe filter to remove any aggregates before injection.

Protocol 2: Basic NIR Imaging System Calibration for FD-1080

Objective: To ensure consistent and reproducible imaging results by calibrating the NIR imaging system.

Materials:

- A stable, uniform NIR light source or a phantom with a known concentration of **FD-1080**.
- Imaging system software.

Procedure:

- System Warm-up: Turn on the laser source and detector and allow them to warm up for at least 30 minutes to ensure stable output.
- Dark Current Correction: With the laser off and the detector cap on, acquire a series of "dark" frames. Average these frames to create a master dark frame. This will be subtracted from subsequent images to correct for detector noise.
- Flat-Field Correction:
 - Use a uniform NIR light source or a well-mixed solution of **FD-1080** in a phantom to create a uniform field of illumination.
 - Acquire a series of images of the uniform field.
 - Average these images to create a master flat-field frame.
 - Divide your experimental images by this master flat-field frame to correct for non-uniformities in the illumination and detector response.
- Signal Linearity Check:
 - Prepare a serial dilution of the **FD-1080**-FBS complex.
 - Image each concentration under the same settings.
 - Plot the mean fluorescence intensity against the concentration. The relationship should be linear within a certain range. This helps determine the dynamic range of your system for this fluorophore.

Visualizations

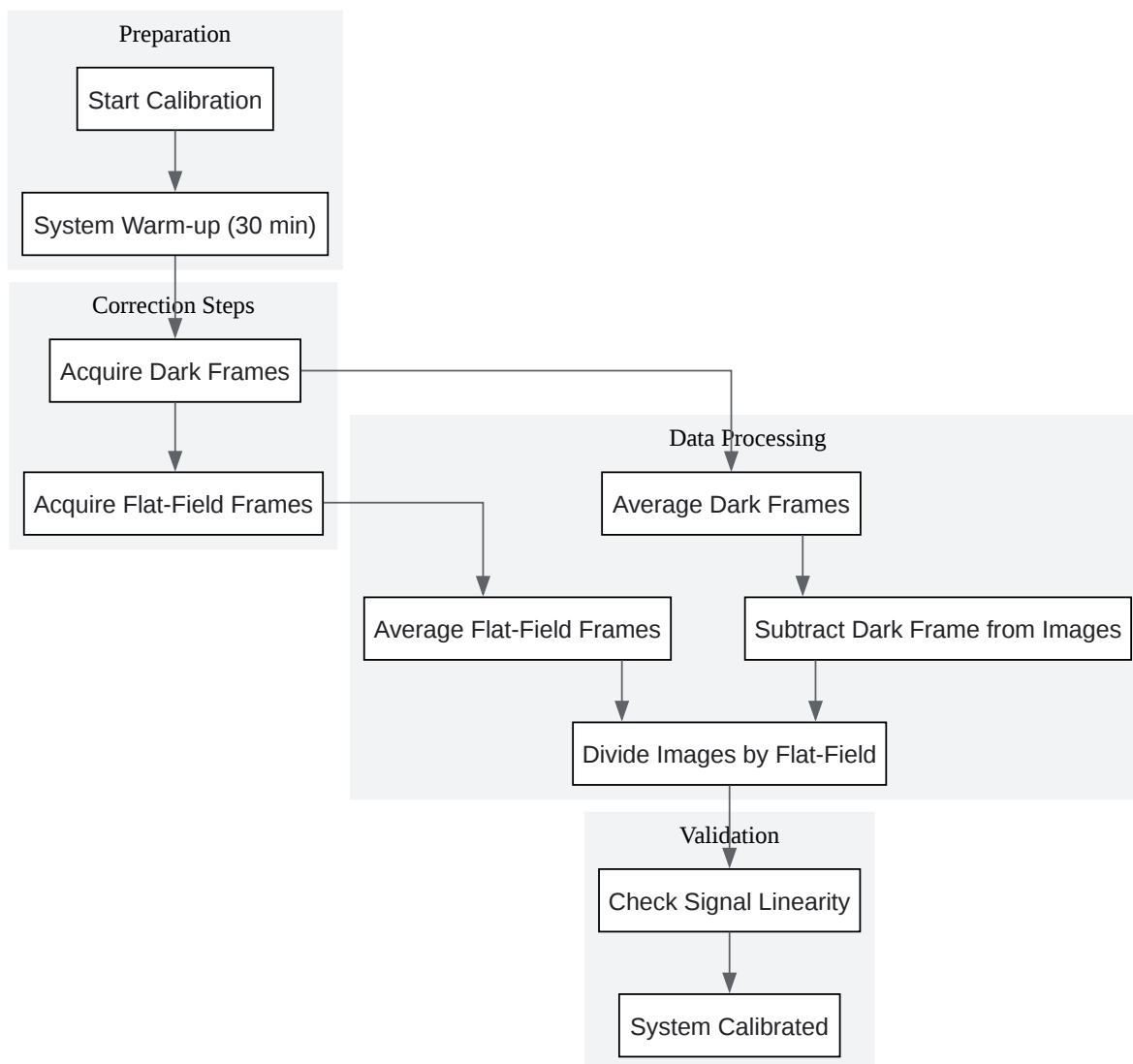

[Click to download full resolution via product page](#)

Caption: Workflow for basic NIR imaging system calibration.

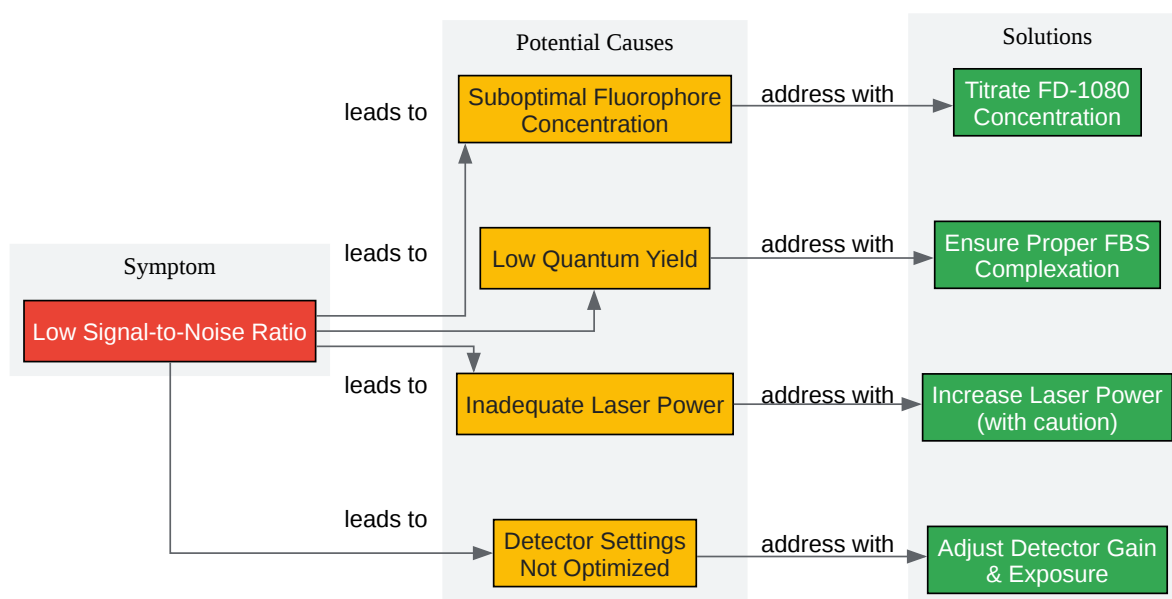

[Click to download full resolution via product page](#)

Caption: Troubleshooting logic for low signal-to-noise ratio.

Need Custom Synthesis?

BenchChem offers custom synthesis for rare earth carbides and specific isotopic labeling.

Email: info@benchchem.com or [Request Quote Online](#).

References

- 1. [researchgate.net \[researchgate.net\]](#)
- 2. [researchgate.net \[researchgate.net\]](#)

- [3. Construction and optimization of organic fluorophores in NIR-II fluorescence imaging - Chemical Society Reviews \(RSC Publishing\) \[pubs.rsc.org\]](#)
- [4. Engineered NIR-II fluorophores with ultralong-distance molecular packing for high-contrast deep lesion identification - PMC \[pmc.ncbi.nlm.nih.gov\]](#)
- [5. Frontiers | Organic Fluorophores for 1064 nm Excited NIR-II Fluorescence Imaging \[frontiersin.org\]](#)
- To cite this document: BenchChem. [Technical Support Center: Imaging with FD-1080 Fluorophore]. BenchChem, [2026]. [Online PDF]. Available at: [\[https://www.benchchem.com/product/b12296719/docs#technical-support-center-imaging-with-fd-1080-fluorophore\]](https://www.benchchem.com/product/b12296719/docs#technical-support-center-imaging-with-fd-1080-fluorophore)

Disclaimer & Data Validity:

The information provided in this document is for Research Use Only (RUO) and is strictly not intended for diagnostic or therapeutic procedures. While BenchChem strives to provide accurate protocols, we make no warranties, express or implied, regarding the fitness of this product for every specific experimental setup.

Technical Support: The protocols provided are for reference purposes. Unsure if this reagent suits your experiment?

Need Industrial/Bulk Grade? [Request Custom Synthesis Quote](#)

BenchChem

Our mission is to be the trusted global source of essential and advanced chemicals, empowering scientists and researchers to drive progress in science and industry.

Contact

Address: 3281 E Guasti Rd
Ontario, CA 91761, United States
Phone: (601) 213-4426
Email: info@benchchem.com

Contact our Ph.D. Support Team for a compatibility check