

# T-448 (EOS-448) In Vivo Delivery Technical Support Center

**Author:** BenchChem Technical Support Team. **Date:** April 2026

## Compound of Interest

Compound Name: T-448  
Cat. No.: B12296387

[Get Quote](#)

Welcome to the technical support center for the in vivo application of **T-448** (also known as EOS-448 or GSK4428859A), an antagonistic anti-TIGIT human immunoglobulin G1 (hIgG1) antibody. This resource is designed to assist researchers, scientists, and drug development professionals in effectively designing and troubleshooting their preclinical experiments.

## Frequently Asked Questions (FAQs)

Q1: What is the primary mechanism of action for **T-448**?

A1: **T-448** is an anti-TIGIT monoclonal antibody with a dual mechanism of action. Firstly, it blocks the interaction between TIGIT (T cell immunoglobulin and ITIM domain), an immune checkpoint receptor expressed on T cells and NK cells, and its ligand CD155 (PVR). This blockade prevents the delivery of inhibitory signals to T cells and NK cells, thereby restoring their anti-tumor activity. Secondly, as a human IgG1 antibody, **T-448** possesses a functional Fc domain that engages Fc gamma receptors (FcγR) on myeloid cells and NK cells.<sup>[1][2]</sup> This engagement leads to the activation of these immune cells and the depletion of highly TIGIT-expressing cells, such as regulatory T cells (Tregs) and terminally exhausted T cells, further enhancing the anti-tumor immune response.<sup>[1][3][4][5]</sup>

Q2: In which preclinical models has **T-448** shown efficacy?

A2: **T-448** has demonstrated potent anti-tumor activity in various murine cancer models.[1] For instance, in a CT26 colon carcinoma model in BALB/c mice, a murine surrogate of **T-448** in combination with an anti-PD-1 antibody showed a strong anti-tumor effect.[6][7] Preclinical data has also been presented showing its efficacy as a single agent and in combination with an immunomodulatory imide drug (IMiD) in a preclinical model of multiple myeloma.[5]

Q3: What is the recommended formulation and storage for in vivo use?

A3: For in vivo studies, **T-448** should be formulated in a sterile, buffered solution such as phosphate-buffered saline (PBS) at a neutral pH. It is crucial to use a low-endotoxin formulation for in vivo applications to avoid non-specific inflammatory responses. Commercially available anti-TIGIT antibodies for in vivo use are often supplied in 0.01 M PBS (pH 7.2) with 150 mM NaCl, without carrier proteins or preservatives. For short-term storage, the antibody solution is stable at 2-8°C for at least four weeks. For long-term storage, it is recommended to aseptically aliquot the antibody into working volumes and store at -80°C. Avoid repeated freeze-thaw cycles.

Q4: What are the potential adverse effects of anti-TIGIT antibodies in mice?

A4: In preclinical studies, anti-TIGIT antibodies have been generally well-tolerated.[8] However, as with other immunotherapies, there is a potential for immune-related adverse events (irAEs) due to the enhanced immune response.[8] Common side effects observed in clinical trials with anti-TIGIT antibodies include fatigue, pruritus (itching), and infusion-related reactions, which are generally mild to moderate in severity.[9][10] Researchers should monitor animals for signs of distress, weight loss, and other indicators of toxicity.

## Troubleshooting In Vivo Delivery

Issue	Potential Cause	Recommended Solution
Lack of therapeutic efficacy	Suboptimal dosing or schedule: The dose or frequency of administration may be insufficient to achieve a therapeutic concentration at the tumor site.	Titrate the dose of T-448 to determine the optimal therapeutic window for your specific tumor model. A common starting point in mice is in the range of 100-500 µg per mouse. A dosing schedule of once every 3 days has been reported.[7]
Antibody aggregation or degradation: Improper storage or handling can lead to loss of antibody function.	Ensure the antibody is stored correctly at -80°C for long-term storage and 4°C for short-term use. Avoid repeated freeze-thaw cycles. Visually inspect the solution for precipitates before administration.	
Inappropriate animal model: The tumor model may not be sensitive to TIGIT blockade.	Confirm TIGIT expression on tumor-infiltrating lymphocytes in your chosen model. Models with a high degree of T-cell infiltration and TIGIT expression are more likely to respond.	
Development of anti-drug antibodies (ADAs): Repeated administration of a humanized antibody in mice can lead to an immune response against the therapeutic antibody, reducing its efficacy.	Consider using a murine surrogate antibody if available for longer-term studies. Monitor for signs of reduced efficacy over time.	
High variability in tumor growth between animals	Inconsistent tumor cell implantation: Variation in the number of viable tumor cells injected or the injection site	Standardize the tumor cell implantation procedure, ensuring a consistent number of viable cells are injected into

	can lead to different tumor growth rates.	the same anatomical location for each animal.
Inaccurate antibody administration: Inconsistent injection volume or location (e.g., subcutaneous instead of intraperitoneal) can affect antibody bioavailability.	Ensure all personnel are properly trained in the chosen administration technique (e.g., intraperitoneal injection). Use a consistent and precise injection volume for each animal.	
Adverse events in treated animals (e.g., weight loss, lethargy)	Immune-related adverse events (irAEs): Over-activation of the immune system can lead to off-target effects.	Closely monitor the health of the animals daily. If adverse events are observed, consider reducing the dose or frequency of administration.
High endotoxin levels in the antibody preparation: Contamination with endotoxins can cause a systemic inflammatory response.	Use only low-endotoxin certified antibodies and sterile, pyrogen-free reagents and equipment for all in vivo experiments.	

## Experimental Protocols

### Protocol 1: In Vivo Efficacy Study of T-448 in a Syngeneic Mouse Tumor Model (CT26)

#### 1. Animal Model:

- 6-8 week old female BALB/c mice.
- Acclimatize animals for at least one week before the start of the experiment.

#### 2. Tumor Cell Implantation:

- Culture CT26 colon carcinoma cells in appropriate media.
- On Day 0, harvest cells and resuspend in sterile PBS at a concentration of  $5 \times 10^6$  cells/mL.

- Subcutaneously inject 100  $\mu$ L of the cell suspension ( $5 \times 10^5$  cells) into the right flank of each mouse.

### 3. Treatment Groups:

- Group 1: Vehicle control (sterile PBS, intraperitoneal injection).
- Group 2: **T-448** (e.g., 200  $\mu$ g/mouse, intraperitoneal injection).[7]
- Group 3: Isotype control antibody (human IgG1, 200  $\mu$ g/mouse, intraperitoneal injection).
- Group 4 (Optional): **T-448** in combination with an anti-PD-1 antibody.

### 4. Dosing Regimen:

- Begin treatment when tumors reach a palpable size (e.g., 50-100  $\text{mm}^3$ ).
- Administer treatment once every 3 days for a total of 3 doses via intraperitoneal (IP) injection.[7]

### 5. Monitoring and Endpoints:

- Measure tumor volume using calipers every 2-3 days. Tumor volume ( $\text{mm}^3$ ) =  $(\text{length} \times \text{width}^2)/2$ .
- Monitor animal body weight and overall health status daily.
- Euthanize animals when tumors reach the maximum allowed size as per institutional guidelines or if signs of significant toxicity are observed.
- At the end of the study, tumors and spleens can be harvested for further analysis (e.g., flow cytometry to assess immune cell populations).

## Protocol 2: Intraperitoneal (IP) Injection in Mice

### 1. Preparation:

- Warm the **T-448** solution to room temperature to avoid causing discomfort to the animal.

- Use a new sterile syringe and a 25-30 gauge needle for each animal.

## 2. Restraint:

- Gently restrain the mouse by grasping the loose skin over the shoulders and neck.
- Turn the mouse over to expose its abdomen. The hindquarters can be secured by tucking the tail.

## 3. Injection:

- Identify the injection site in the lower right quadrant of the abdomen to avoid injuring the cecum or bladder.
- Wipe the injection site with an alcohol swab.
- Insert the needle, bevel up, at a 30-45° angle into the peritoneal cavity.
- Gently pull back on the plunger to ensure no fluid or feces are aspirated, which would indicate incorrect placement.
- Slowly inject the antibody solution.
- Withdraw the needle and return the mouse to its cage.

## 4. Post-injection Monitoring:

- Observe the animal for any immediate adverse reactions.

# Data Presentation

Table 1: Example of Tumor Growth Inhibition Data

Treatment Group	N	Mean Tumor Volume (mm <sup>3</sup> ) at Day 14 ± SEM	Percent Tumor Growth Inhibition (%)
Vehicle Control	10	1200 ± 150	-
Isotype Control	10	1150 ± 130	4.2
T-448 (10 mg/kg)	10	600 ± 90	50
T-448 + anti-PD-1	10	250 ± 50	79.2

Table 2: Example of Immune Cell Population Changes in the Tumor Microenvironment

Treatment Group	% CD8+ T cells of CD45+ cells	% Regulatory T cells (FoxP3+) of CD4+ T cells	CD8+/Treg Ratio
Vehicle Control	15.2 ± 2.1	25.8 ± 3.5	0.59
T-448	25.6 ± 3.4	12.3 ± 1.8	2.08

## Visualizations

### Signaling Pathways and Experimental Workflows

T-448 (EOS-448) Mechanism of Action

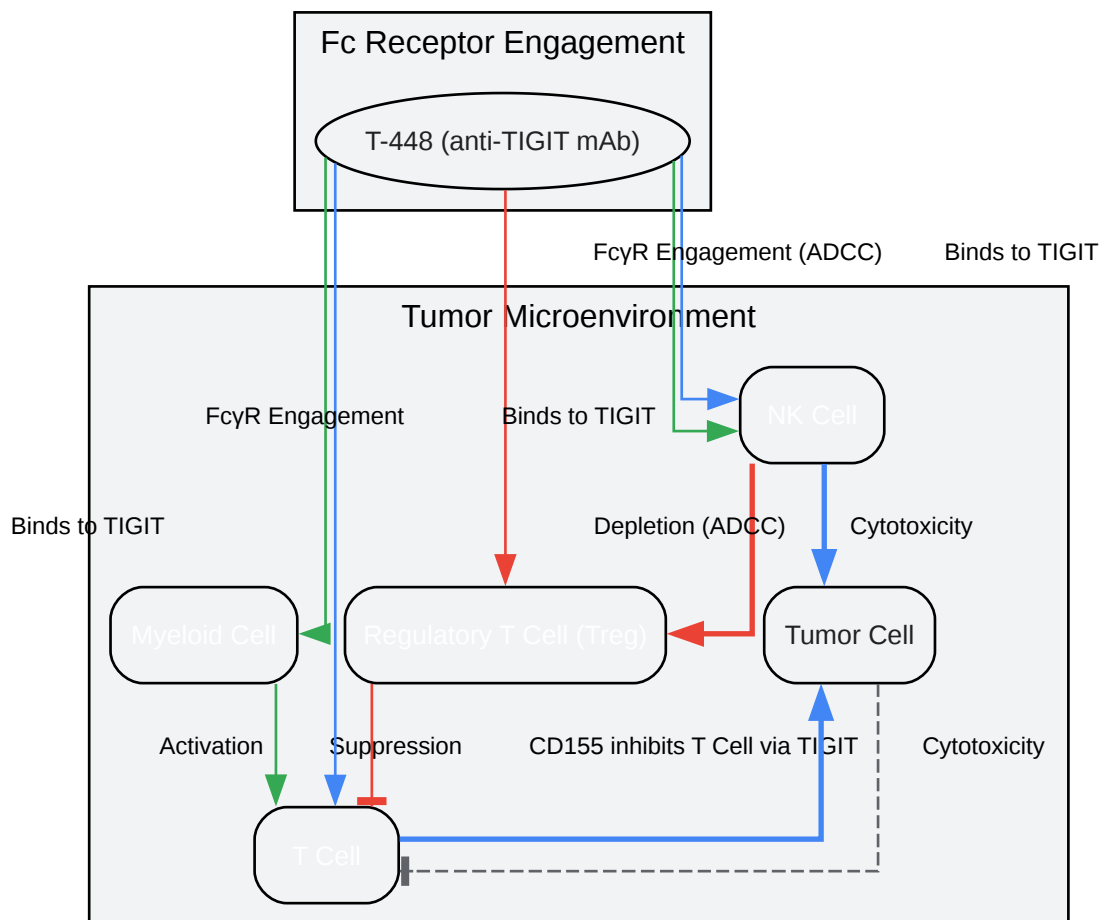

[Click to download full resolution via product page](#)

Caption: Mechanism of action of **T-448** (EOS-448).

T-448 In Vivo Efficacy Study Workflow

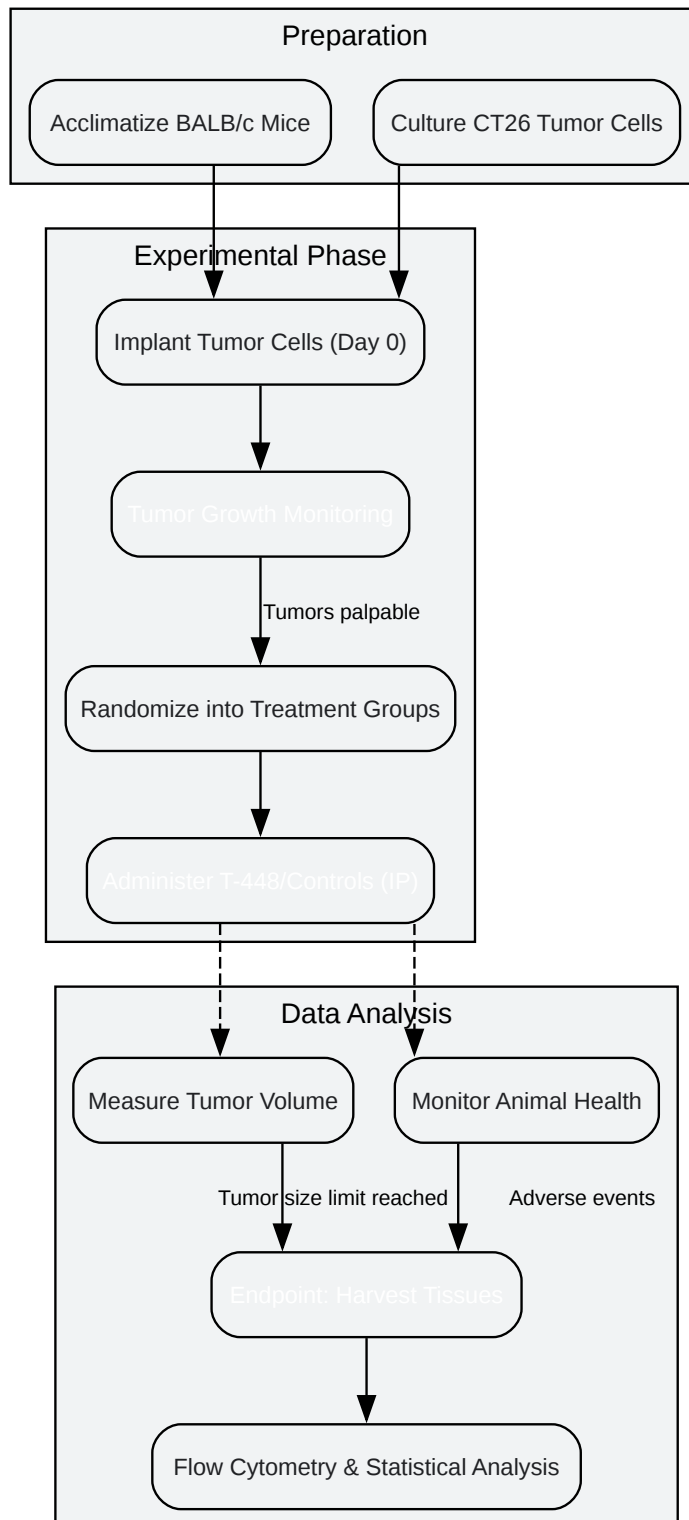

[Click to download full resolution via product page](#)

Caption: Workflow for a typical in vivo efficacy study of **T-448**.

### Need Custom Synthesis?

BenchChem offers custom synthesis for rare earth carbides and specific isotopic labeling.

Email: [info@benchchem.com](mailto:info@benchchem.com) or [Request Quote Online](#).

## References

- [1. researchgate.net \[researchgate.net\]](https://www.researchgate.net)
- [2. gsk.com \[gsk.com\]](https://www.gsk.com)
- [3. firstwordpharma.com \[firstwordpharma.com\]](https://www.firstwordpharma.com)
- [4. iTeos Presents New Data for Anti-TIGIT Antibody, \[globenewswire.com\]](https://www.globenewswire.com)
- [5. iTeos Announces New Data for its Anti-TIGIT Antibody, EOS-448, at the American Society of Hematology Annual Meeting and TIGIT Therapies Digital Summit 2021 | GlobeNewswire by notified \[kommunikasjon.ntb.no\]](https://www.globe-newswire.com)
- [6. aacrjournals.org \[aacrjournals.org\]](https://www.aacrjournals.org)
- [7. medchemexpress.com \[medchemexpress.com\]](https://www.medchemexpress.com)
- [8. kuickresearch.com \[kuickresearch.com\]](https://www.kuickresearch.com)
- [9. Targeting TIGIT in lung cancer: will it stick to the wall? - Niu - AME Clinical Trials Review \[actr.amegroups.org\]](https://www.actr.amegroups.org)
- [10. Anti-TIGIT therapies for solid tumors: a systematic review - PMC \[pmc.ncbi.nlm.nih.gov\]](https://pubmed.ncbi.nlm.nih.gov)
- To cite this document: BenchChem. [T-448 (EOS-448) In Vivo Delivery Technical Support Center]. BenchChem, [2026]. [Online PDF]. Available at: [\[https://www.benchchem.com/product/b12296387/docs#t-448-eos-448-in-vivo-delivery-technical-support-center\]](https://www.benchchem.com/product/b12296387/docs#t-448-eos-448-in-vivo-delivery-technical-support-center)

---

### Disclaimer & Data Validity:

The information provided in this document is for Research Use Only (RUO) and is strictly not intended for diagnostic or therapeutic procedures. While BenchChem strives to provide accurate protocols, we make no warranties, express or implied, regarding the fitness of this product for every specific experimental setup.

**Technical Support:** The protocols provided are for reference purposes. Unsure if this reagent suits your experiment?

**Need Industrial/Bulk Grade?** [Request Custom Synthesis Quote](#)

## BenchChem

Our mission is to be the trusted global source of essential and advanced chemicals, empowering scientists and researchers to drive progress in science and industry.

### Contact

Address: 3281 E Guasti Rd  
Ontario, CA 91761, United States  
Phone: (601) 213-4426  
Email: [info@benchchem.com](mailto:info@benchchem.com)

[Contact our Ph.D. Support Team for a compatibility check](#)