

Application Note: Forced Degradation Study Design for Caspofungin Acetate

Author: BenchChem Technical Support Team. **Date:** April 2026

Compound of Interest

Compound Name: Caspofungin impurity A

Cat. No.: B12289642

[Get Quote](#)

Introduction

Caspofungin is a semi-synthetic lipopeptide antifungal agent belonging to the echinocandin class. It is primarily used in the treatment of invasive fungal infections. As with any pharmaceutical compound, a thorough understanding of its stability characteristics is crucial for the development of a safe, effective, and stable formulation. Forced degradation studies are an integral part of the drug development process, providing insights into the intrinsic stability of the drug substance, potential degradation pathways, and aiding in the development and validation of stability-indicating analytical methods.[1] This application note provides a detailed protocol for conducting a forced degradation study on caspofungin acetate, outlining the stress conditions, analytical methodology, and expected outcomes.

Caspofungin is known to be susceptible to degradation through hydrolysis (both acidic and basic), oxidation, and thermal stress.[1][2] Its primary degradation pathways involve the hydrolysis of the peptide backbone, leading to the formation of open-ring structures and other related impurities.[3][4] Understanding the profile of these degradation products is essential for ensuring the quality and safety of the final drug product.

Experimental Design

The forced degradation study is designed to expose caspofungin acetate to a range of stress conditions, including acid and base hydrolysis, oxidation, heat, and light, as recommended by the International Council for Harmonisation (ICH) guidelines.

Materials and Reagents

- Caspofungin Acetate Active Pharmaceutical Ingredient (API)
- Hydrochloric Acid (HCl), 0.1 N and 0.5 M[1][2]
- Sodium Hydroxide (NaOH), 0.1 N and 0.5 M[1][2]
- Hydrogen Peroxide (H₂O₂), 30% and 0.2%[1][2]
- Acetonitrile (HPLC grade)
- 2-Propanol (HPLC grade)
- Phosphoric Acid (for pH adjustment)
- Water (HPLC grade)
- Volumetric flasks, pipettes, and other standard laboratory glassware
- pH meter
- HPLC system with UV or PDA detector
- Analytical column: YMC-Pack Polyamine II (150x4.6 mm, 5 μm) or equivalent C18 column[1][2]
- Temperature-controlled oven
- Photostability chamber

Experimental Protocols

Preparation of Stock Solution

Prepare a stock solution of caspofungin acetate in a suitable solvent (e.g., water or a hydro-alcoholic mixture) at a concentration of approximately 1 mg/mL. This stock solution will be used for all stress studies.

Forced Degradation Conditions

- To 1 mL of the caspofungin stock solution, add 1 mL of 0.1 N HCl.
- Keep the solution at room temperature for a specified period (e.g., 24 hours). In a more aggressive approach, the drug can be treated with 0.5 M HCl at 50°C for 30 minutes.[2]
- After the incubation period, neutralize the solution with an appropriate volume of 0.1 N NaOH.
- Dilute the resulting solution with the mobile phase to a final concentration of approximately 100 µg/mL for HPLC analysis.
- To 1 mL of the caspofungin stock solution, add 1 mL of 0.1 N NaOH.
- Maintain the solution at room temperature for a specified duration (e.g., 24 hours). Alternatively, for a faster degradation, 0.5 M NaOH can be used at room temperature for 30 minutes.[2]
- Following incubation, neutralize the solution with an equivalent volume of 0.1 N HCl.
- Dilute the final solution with the mobile phase to a concentration of about 100 µg/mL for HPLC analysis.
- Mix 1 mL of the caspofungin stock solution with 1 mL of 30% H₂O₂. [1]
- Store the mixture at room temperature for a defined time (e.g., 24 hours). A less concentrated peroxide solution (0.2% H₂O₂) can also be used for 20 minutes at room temperature.[2]
- Dilute the solution with the mobile phase to a final concentration of approximately 100 µg/mL for HPLC analysis.

- Place a sample of the caspofungin stock solution in a temperature-controlled oven at 80°C for a sufficient time.[1] Another condition reported is heating at 60°C for 120 hours.[2]
- After heating, allow the sample to cool to room temperature.
- Dilute the solution with the mobile phase to a final concentration of about 100 µg/mL for HPLC analysis.
- Expose the caspofungin stock solution to light providing an overall illumination of not less than 1.2 million lux hours and an integrated near-ultraviolet energy of not less than 200 watt-hours/square meter in a photostability chamber.[2]
- A control sample should be kept in the dark under the same temperature conditions.
- After exposure, dilute the solution with the mobile phase to a final concentration of approximately 100 µg/mL for HPLC analysis.

HPLC Analysis

A stability-indicating HPLC method is crucial for separating the intact drug from its degradation products. The following method is a representative example:

- Column: YMC-Pack Polyamine II (150x4.6 mm, 5 µm)[1]
- Mobile Phase: A mixture of 0.02 M phosphoric acid buffer (pH 3.5), acetonitrile, and 2-propanol in an isocratic elution.[1]
- Flow Rate: 1.0 mL/min[1]
- Detection Wavelength: 210 nm[1]
- Column Temperature: 30°C[1]
- Injection Volume: 10 µL

Data Presentation

The results of the forced degradation study should be summarized in a clear and concise manner. The percentage of degradation can be calculated by comparing the peak area of the intact caspofungin in the stressed samples to that of an unstressed control sample.

Table 1: Summary of Forced Degradation Results for Caspofungin Acetate

Stress Condition	Reagent/Condition	Duration/Temperature	% Degradation
Acid Hydrolysis	0.1 N HCl	Room Temperature	25.17% ^[1]
Alkaline Hydrolysis	0.1 N NaOH	Room Temperature	22.46% ^[1]
Oxidative	30% H ₂ O ₂	Room Temperature	26.5% ^[1]
Thermal	Heat	80°C	17.21% ^[1]
Photolytic	1.2 million lux hours and 200 Wh/m ²	Ambient	Not Reported

Visualization of Experimental Workflow

The following diagram illustrates the workflow for the forced degradation study of caspofungin.

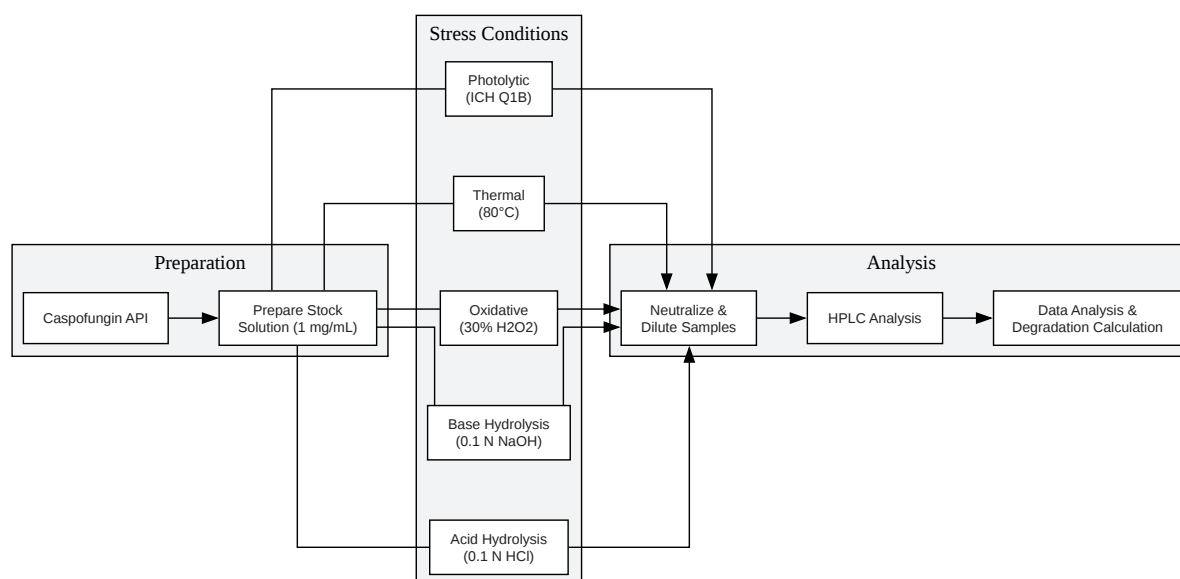

[Click to download full resolution via product page](#)

Caption: Workflow for the forced degradation study of Caspofungin.

Discussion and Conclusion

The forced degradation study of caspofungin acetate reveals its susceptibility to hydrolysis, oxidation, and thermal stress. The significant degradation observed under these conditions underscores the importance of controlling pH, protecting from oxidative environments, and maintaining appropriate storage temperatures for caspofungin formulations. The primary degradation product under hydrolytic conditions is often reported as caspofungin impurity B.[5]

The developed stability-indicating HPLC method effectively separates the parent drug from its major degradation products, allowing for accurate quantification of the extent of degradation. The data generated from this study is invaluable for the development of a stable and robust formulation of caspofungin, as well as for setting appropriate specifications for the drug substance and drug product. Further characterization of the degradation products using techniques such as mass spectrometry can provide a more comprehensive understanding of the degradation pathways.

Need Custom Synthesis?

BenchChem offers custom synthesis for rare earth carbides and specific isotopic labeling.

Email: info@benchchem.com or [Request Quote Online](#).

References

- [1. ijapbjournal.com \[ijapbjournal.com\]](http://ijapbjournal.com)
- [2. impactfactor.org \[impactfactor.org\]](http://impactfactor.org)
- [3. Assessment and Development of the Antifungal Agent Caspofungin for Aerosolized Pulmonary Delivery - PMC \[pmc.ncbi.nlm.nih.gov\]](https://pubmed.ncbi.nlm.nih.gov/)
- [4. Caspofungin - Wikipedia \[en.wikipedia.org\]](https://en.wikipedia.org/)
- [5. bocsci.com \[bocsci.com\]](http://bocsci.com)
- To cite this document: BenchChem. [Application Note: Forced Degradation Study Design for Caspofungin Acetate]. BenchChem, [2026]. [Online PDF]. Available at: [\[https://www.benchchem.com/product/b12289642/docs#application-note-forced-degradation-study-design-for-caspofungin-acetate\]](https://www.benchchem.com/product/b12289642/docs#application-note-forced-degradation-study-design-for-caspofungin-acetate)

Disclaimer & Data Validity:

The information provided in this document is for Research Use Only (RUO) and is strictly not intended for diagnostic or therapeutic procedures. While BenchChem strives to provide accurate protocols, we make no warranties, express or implied, regarding the fitness of this product for every specific experimental setup.

Technical Support: The protocols provided are for reference purposes. Unsure if this reagent suits your experiment?

Need Industrial/Bulk Grade? [Request Custom Synthesis Quote](#)

BenchChem

Our mission is to be the trusted global source of essential and advanced chemicals, empowering scientists and researchers to drive progress in science and industry.

Contact

Address: 3281 E Guasti Rd
Ontario, CA 91761, United States
Phone: (601) 213-4426
Email: info@benchchem.com

[Contact our Ph.D. Support Team for a compatibility check](#)