

Technical Support Center: Mitigating Off-Target Effects of High-Dose Estradiol Valerate

Author: BenchChem Technical Support Team. **Date:** April 2026

Compound of Interest

Compound Name: *Estrofem*
CAS No.: 65296-29-9
Cat. No.: B1228796

[Get Quote](#)

This technical support center provides researchers, scientists, and drug development professionals with troubleshooting guides and frequently asked questions (FAQs) to mitigate the off-target effects of high-dose estradiol valerate (EV) in experimental settings.

Frequently Asked Questions (FAQs)

Q1: What are the primary off-target effects of high-dose estradiol valerate?

High doses of estradiol valerate, a prodrug of estradiol, can lead to supraphysiologic levels of estradiol, causing a range of off-target effects.[1][2] These include activation of non-classical estrogen signaling pathways, increased risk of thromboembolism, changes in blood lipid profiles, and insulin resistance.[3][4] In animal models, high doses can inhibit food and water intake, leading to weight loss, or cause fluid retention.[5] A significant off-target mechanism is the activation of the G protein-coupled estrogen receptor (GPER), which can trigger rapid, non-genomic signaling cascades distinct from the classical nuclear estrogen receptors (ER α and ER β).[6][7]

Q2: How can I distinguish between on-target (ER α /ER β) and off-target (e.g., GPER) effects in my experiments?

To differentiate receptor-specific effects, a combination of selective agonists and antagonists is recommended. For example, using the GPER-selective agonist G-1 or antagonists like G15 and G36 can help isolate GPER-mediated events.[6] Comparing the cellular response to estradiol in the presence and absence of these specific inhibitors can elucidate the signaling pathway responsible for the observed effect. Knockdown of GPER has also been used to confirm its role in observed cellular responses.[8]

Q3: What are the key considerations for in vitro experiments to ensure reproducible results and minimize variability?

To minimize variability and ensure reproducibility in in vitro studies with estradiol valerate, several factors must be strictly controlled:

- **Use Phenol Red-Free Medium:** Phenol red is a weak estrogen agonist and can interfere with results. It is crucial to use phenol red-free medium for at least 24-48 hours before and during the experiment.
- **Use Charcoal-Stripped Serum:** Standard fetal bovine serum (FBS) contains endogenous steroids. Using charcoal-stripped FBS removes these hormones, preventing them from masking the effects of exogenously applied estradiol.[1]
- **Standardize Culture Conditions:** Maintain consistency in media composition, serum batches, incubation times, cell passage number, and CO₂ levels.
- **Include Vehicle Controls:** Always include a control group treated with the same solvent (e.g., ethanol or DMSO) used to dissolve the estradiol valerate to account for any solvent-specific effects.[1]
- **Confirm Receptor Expression:** Verify the expression of ER α , ER β , and GPER in your cell line using methods like qPCR or Western blotting, as receptor levels can influence cellular responsiveness.[1]

Q4: How does the route of administration impact the effects of estradiol valerate in animal models?

The route of administration significantly alters the pharmacokinetics of EV. Intramuscular or subcutaneous injections bypass the extensive first-pass metabolism that occurs with oral administration. This results in 100% bioavailability and the formation of a depot from which estradiol is slowly released, providing sustained and stable hormone levels. Oral administration has a much lower bioavailability (around 5%) and leads to a higher ratio of estrone to estradiol. [1]

Troubleshooting Guides

Guide 1: Unexpected Cellular Proliferation or Apoptosis

- **Observed Issue:** High-dose estradiol valerate induces unexpected levels of cell proliferation or apoptosis in an experimental cell line.
- **Potential Cause:** This may be due to the activation of non-classical, membrane-associated estrogen receptors like GPER, which can trigger rapid signaling cascades such as the PI3K/Akt and ERK pathways, leading to varied cellular responses.[7][9]
- **Troubleshooting Strategy:**
 - **Pathway Analysis:** Investigate the activation of downstream signaling molecules (e.g., p-Akt, p-ERK) via Western blot.
 - **Selective Inhibition:** Use a GPER-specific antagonist (e.g., G15 or G36) in conjunction with estradiol valerate.[6] A reversal of the unexpected effect in the presence of the antagonist points to GPER-mediated signaling.
 - **Dose Reduction:** Perform a dose-response study to find the optimal concentration that elicits the desired on-target effects without significant off-target signaling.

Guide 2: High Variability Between Experimental Replicates

- **Observed Issue:** Significant variability in results is observed between identical in vitro experiments.
- **Potential Causes:**

- Inconsistent cell seeding or use of outer wells in culture plates, which are prone to evaporation.
- Variability in cell responsiveness due to high passage number.[1]
- Interference from estrogenic compounds in the culture medium (phenol red) or serum.[1]
- Degraded estradiol valerate stock solution.[1]
- Troubleshooting Strategy:
 - Refine Cell Culture Technique: Ensure a homogenous cell suspension before seeding, use a consistent cell counting method, and avoid using the outer wells of culture plates.[1]
 - Control Culture Medium: Switch to phenol red-free medium and use charcoal-stripped FBS to eliminate confounding variables.[1]
 - Verify Compound Integrity: Always use freshly prepared solutions of estradiol valerate and ensure proper storage of the stock compound.[1]
 - Cell Line Maintenance: Use cell lines with a consistent and low passage number and periodically verify estrogen receptor expression.[10]

Quantitative Data Summary

Table 1: Receptor Binding Affinity of Estradiol

Receptor	Ligand	Binding Affinity (Kd)
GPER	Estradiol	~3 nM[11]

Note: Data on binding affinities can vary between studies and experimental conditions. This table provides an approximate value based on available literature.

Table 2: Recommended Dosing for Estradiol Valerate in Animal Models

Species	Application	Dosage	Route of Administration	Reference
Rat (250g)	Physiological Replacement	0.5 mg/kg	Subcutaneous or Intramuscular	
Rat	Antidepressant-like effects	Varies	Intramuscular	[12]
Transgender Women	Feminizing Hormone Therapy	5-20 mg every 2 weeks	Intramuscular	
Postmenopausal Women	Menopausal Symptoms	10-20 mg every 4 weeks	Intramuscular	[3][13]

Note: Optimal dosage should be determined through a dose-response study for each specific animal model and experimental goal.[1]

Experimental Protocols

Protocol 1: Competitive Receptor Binding Assay

This protocol is a general guideline for determining the binding affinity of a compound for a specific receptor by measuring its ability to compete with a radiolabeled ligand.

- Preparation:
 - Culture cells expressing the target receptor (e.g., ER α , ER β , or GPER).
 - Prepare cell membrane fractions or use whole cells, depending on the assay design.
 - Prepare a stock solution of a known radiolabeled ligand (e.g., [3 H]-estradiol) and serial dilutions of the unlabeled test compound (estradiol valerate or its active metabolite, estradiol).
- Assay Procedure:

- In a multi-well plate, add a constant concentration of the radiolabeled ligand to each well. [\[14\]](#)
- Add increasing concentrations of the unlabeled competitor compound to the wells. [\[15\]](#)
- Add the cell membrane preparation or whole cells to initiate the binding reaction.
- Include controls for total binding (radioligand + receptor, no competitor) and non-specific binding (radioligand + receptor + excess unlabeled competitor). [\[14\]](#)
- Incubate the plate at a specified temperature for a time sufficient to reach equilibrium.
- Separation and Detection:
 - Separate the bound from the free radioligand using a filter-based system (e.g., MultiScreenHTS plates) and vacuum manifold. [\[16\]](#)
 - Wash the filters to remove unbound radioligand.
 - Measure the radioactivity retained on the filters using a scintillation counter.
- Data Analysis:
 - Plot the percentage of specific binding against the log concentration of the competitor.
 - Determine the IC₅₀ value (the concentration of the competitor that inhibits 50% of the specific binding of the radioligand) using non-linear regression analysis. [\[15\]](#)[\[17\]](#)

Protocol 2: Preparation of Charcoal-Stripped Fetal Bovine Serum (FBS)

- Materials: Dextran-coated charcoal, Fetal Bovine Serum (FBS), magnetic stirrer, sterile centrifuge tubes, sterile filter (0.22 µm).
- Procedure:
 - Prepare a slurry of dextran-coated charcoal in sterile phosphate-buffered saline (PBS).

- Add the charcoal slurry to the FBS (a common ratio is 1 gram of charcoal per 100 mL of serum).
- Incubate the mixture at 37°C for 30-45 minutes with continuous gentle agitation (e.g., on a magnetic stirrer).
- Pellet the charcoal by centrifugation at a high speed (e.g., 10,000 x g) for 15 minutes.
- Carefully decant the supernatant (the stripped serum).
- Repeat the centrifugation step to remove any remaining charcoal particles.
- Sterilize the final charcoal-stripped FBS by passing it through a 0.22 µm filter.
- Store the stripped serum at -20°C.

Visualizations

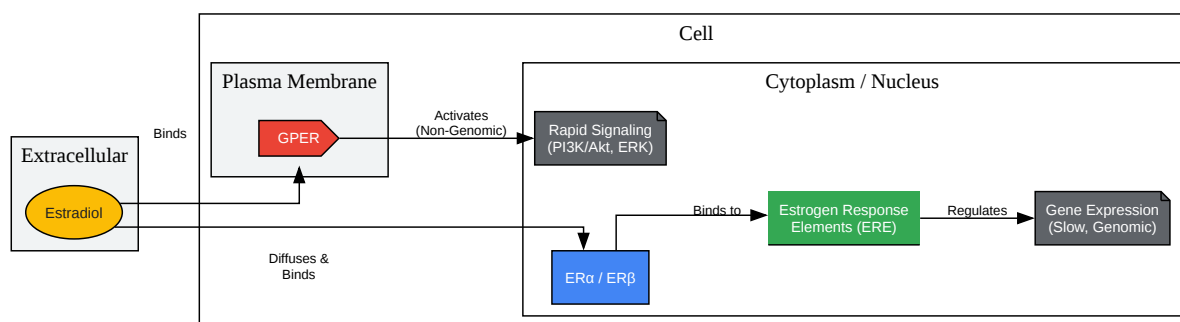

[Click to download full resolution via product page](#)

Caption: Classical (ERα/β) vs. Non-Classical (GPER) Estrogen Signaling Pathways.

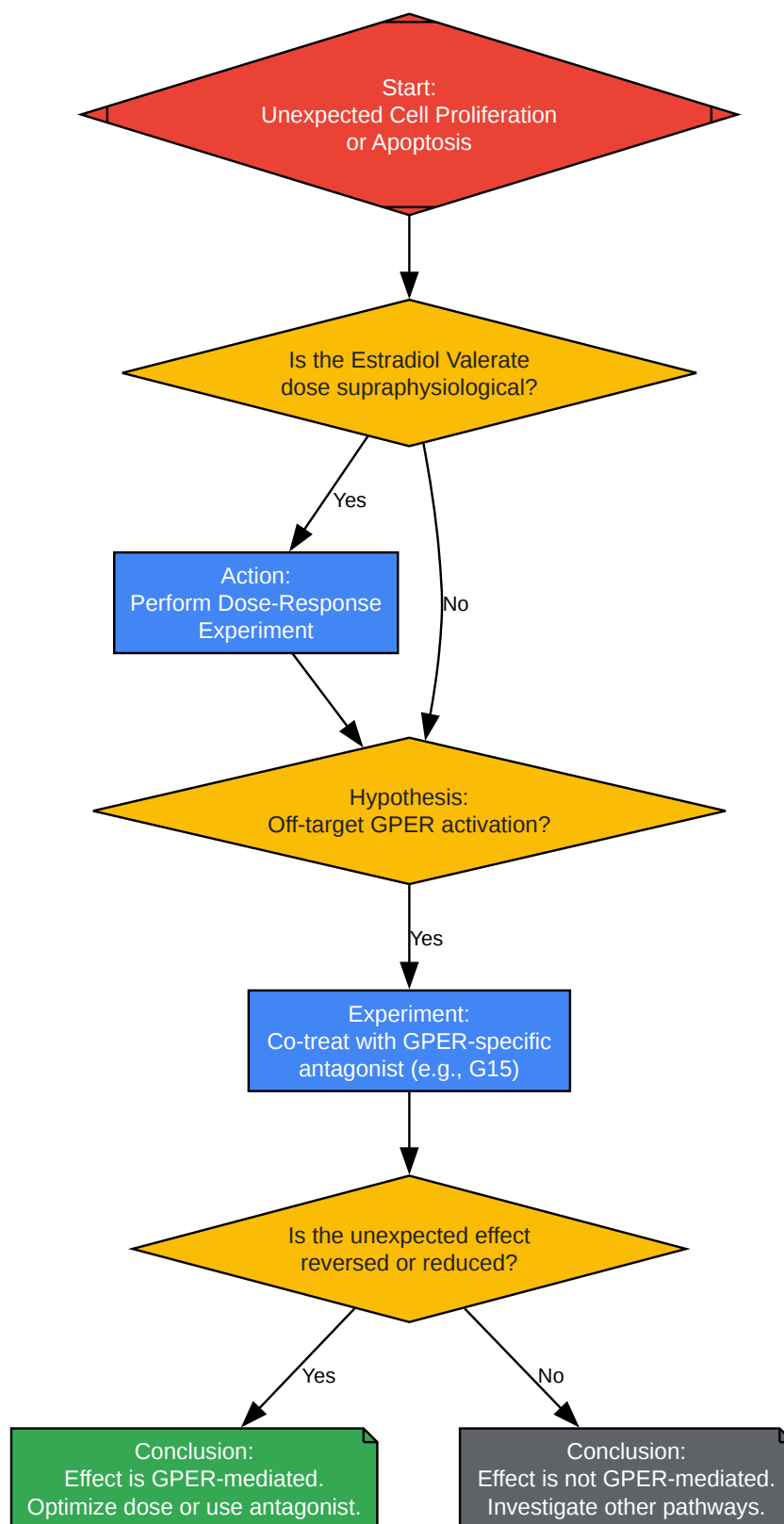

[Click to download full resolution via product page](#)

Caption: Troubleshooting workflow for unexpected cellular responses.

Need Custom Synthesis?

BenchChem offers custom synthesis for rare earth carbides and specific isotopic labeling.

Email: info@benchchem.com or [Request Quote Online](#).

References

- [1. benchchem.com \[benchchem.com\]](https://www.benchchem.com)
- [2. droracle.ai \[droracle.ai\]](https://www.droracle.ai)
- [3. Estradiol valerate - Wikipedia \[en.wikipedia.org\]](https://en.wikipedia.org)
- [4. nbinno.com \[nbinno.com\]](https://www.nbinno.com)
- [5. benchchem.com \[benchchem.com\]](https://www.benchchem.com)
- [6. GPER - Wikipedia \[en.wikipedia.org\]](https://en.wikipedia.org)
- [7. The Role of G Protein-Coupled Estrogen Receptor \(GPER\) in Vascular Pathology and Physiology - PMC \[pmc.ncbi.nlm.nih.gov\]](https://pubmed.ncbi.nlm.nih.gov)
- [8. Exploiting off-target effects of estrogen deprivation to sensitize estrogen receptor negative breast cancer to immune killing - PubMed \[pubmed.ncbi.nlm.nih.gov\]](https://pubmed.ncbi.nlm.nih.gov)
- [9. G protein-coupled estrogen receptor 1 \(GPER\) activation triggers different signaling pathways on neurons and astrocytes - PMC \[pmc.ncbi.nlm.nih.gov\]](https://pubmed.ncbi.nlm.nih.gov)
- [10. benchchem.com \[benchchem.com\]](https://www.benchchem.com)
- [11. Estrogen Biology: New Insights into GPER Function and Clinical Opportunities - PMC \[pmc.ncbi.nlm.nih.gov\]](https://pubmed.ncbi.nlm.nih.gov)
- [12. benchchem.com \[benchchem.com\]](https://www.benchchem.com)
- [13. Delestrogen \(estradiol valerate\): Uses, Side Effects & More - GoodRx \[goodrx.com\]](https://www.goodrx.com)
- [14. Receptor Binding Assays for HTS and Drug Discovery - Assay Guidance Manual - NCBI Bookshelf \[ncbi.nlm.nih.gov\]](https://bookshelf.ncbi.nlm.nih.gov)
- [15. researchgate.net \[researchgate.net\]](https://www.researchgate.net)
- [16. merckmillipore.com \[merckmillipore.com\]](https://www.merckmillipore.com)
- [17. A Flow Cytometry-based Assay to Identify Compounds That Disrupt Binding of Fluorescently-labeled CXC Chemokine Ligand 12 to CXC Chemokine Receptor 4 - PMC \[pmc.ncbi.nlm.nih.gov\]](https://pubmed.ncbi.nlm.nih.gov)

- To cite this document: BenchChem. [Technical Support Center: Mitigating Off-Target Effects of High-Dose Estradiol Valerate]. BenchChem, [2026]. [Online PDF]. Available at: [<https://www.benchchem.com/product/b1228796/docs#technical-support-center-mitigating-off-target-effects-of-high-dose-estradiol-valerate>]

Disclaimer & Data Validity:

The information provided in this document is for Research Use Only (RUO) and is strictly not intended for diagnostic or therapeutic procedures. While BenchChem strives to provide accurate protocols, we make no warranties, express or implied, regarding the fitness of this product for every specific experimental setup.

Technical Support: The protocols provided are for reference purposes. Unsure if this reagent suits your experiment?

Need Industrial/Bulk Grade? [Request Custom Synthesis Quote](#)

BenchChem

Our mission is to be the trusted global source of essential and advanced chemicals, empowering scientists and researchers to drive progress in science and industry.

Contact

Address: 3281 E Guasti Rd
Ontario, CA 91761, United States
Phone: (601) 213-4426
Email: info@benchchem.com

[Contact our Ph.D. Support Team for a compatibility check](#)