

Application Notes: Immunohistochemical Analysis of Hormone Receptor Expression

Author: BenchChem Technical Support Team. **Date:** May 2026

Compound of Interest

Compound Name: Estradiol and norethindrone acetate
CAS No.: 77728-33-7
Cat. No.: B1228784

[Get Quote](#)

Introduction

Immunohistochemistry (IHC) is a cornerstone technique for identifying the expression and localization of hormone receptors—specifically the Estrogen Receptor (ER), Progesterone Receptor (PR), and Androgen Receptor (AR)—within tissue samples. The status of these receptors is critical in both clinical diagnostics and drug development, particularly in oncology, where they serve as prognostic and predictive biomarkers.^{[1][2]} For instance, ER and PR status in breast cancer is essential for determining patient eligibility for endocrine therapies.^{[2][3][4]} Accurate and reproducible IHC results depend on meticulous adherence to validated protocols, including stringent control over pre-analytical variables, validated reagents, and standardized interpretation criteria.^{[1][5]}

Pre-analytical Variables

Pre-analytical factors are a major source of variability in IHC staining and can lead to inaccurate results.^{[6][7]} Key variables include time to fixation, fixation duration, and the type of fixative used.

- Time to Fixation (Cold Ischemia Time): The time between tissue removal and its placement in a fixative should be minimized. Delays can lead to degradation of antigens, potentially causing false-negative results for ER and PR.[6]
- Fixation: 10% neutral buffered formalin (NBF) is the standard fixative.[7][8] The duration of fixation is critical; ASCO/CAP guidelines recommend a fixation time of 6 to 72 hours for breast cancer specimens.[1] Under-fixation (<6 hours) can result in poor tissue morphology and antigen preservation, while over-fixation (>72 hours) can mask epitopes, requiring more aggressive antigen retrieval.[7]

Parameter	Recommendation	Rationale
Time to Fixation	As soon as possible (ideally <1 hour)	Minimizes protein degradation and antigen loss.[6]
Fixative	10% Neutral Buffered Formalin (NBF)	Standard fixative that preserves morphology and antigenicity.[7]
Fixation Duration	6 to 72 hours	Ensures adequate fixation without excessive antigen masking.[1]
Tissue Thickness	4 μ m	Allows for optimal reagent penetration and visualization. [8]

Table 1: Critical Pre-analytical Factors for Hormone Receptor IHC.

Antibody Selection

The choice of primary antibody is crucial for the specificity and sensitivity of the assay. Several well-validated monoclonal antibody clones are available for detecting hormone receptors in formalin-fixed, paraffin-embedded (FFPE) tissues.

Target Receptor	Recommended Clones	Host Species	Notes
Estrogen Receptor (ER α)	1D5, EP1	Mouse, Rabbit	Widely used and validated clones for clinical and research applications. [2] [9]
Progesterone Receptor (PR)	PgR 636, PgR 1294	Mouse, Rabbit	Recognized for high specificity and performance in FFPE tissues. [2] [9]
Androgen Receptor (AR)	AR441, IHC037, ZR334	Mouse, Rabbit	Used for determining AR status, particularly in prostate and breast cancer research. [10] [11]

Table 2: Recommended Primary Antibodies for Hormone Receptor IHC.

Controls for Assay Validation

Proper controls are mandatory to ensure the accuracy and validity of IHC staining runs.

- **Positive Tissue Control:** Consists of tissue known to express the target antigen (e.g., normal breast or endometrial tissue for ER/PR). It verifies the entire staining procedure.[\[1\]](#)[\[12\]](#)
- **Negative Tissue Control:** Consists of tissue known to be negative for the target antigen. It helps to identify non-specific staining.
- **Internal Controls:** Non-neoplastic cells within the patient sample that are expected to be positive for the hormone receptor (e.g., normal breast ducts) can serve as an invaluable internal positive control.[\[1\]](#)[\[12\]](#) The absence of staining in internal controls may indicate a technical failure.[\[1\]](#)
- **Negative Reagent Control:** The primary antibody is omitted and replaced with a non-immune serum from the same species to check for non-specific staining from the detection system.

Interpretation and Scoring

The interpretation of hormone receptor staining should be performed by a trained professional and is based on nuclear staining.

- **ER and PR Scoring (ASCO/CAP Guidelines):** For breast cancer, a tumor is considered positive if at least 1% of the tumor cell nuclei show positive staining.[1] A new category, "ER Low Positive," has been introduced for cases with 1-10% positive cells, as these patients may still derive some benefit from endocrine therapy.[13]
- **Scoring Systems:** The Allred score and H-Score are semi-quantitative methods that incorporate both the percentage of positive cells and the intensity of the staining. While the 1% threshold determines positivity, these scores can provide more detailed information.[12] [14]
- **AR Scoring:** There is less standardization for AR scoring, but a common cutoff is $\geq 1\%$ positive nuclear staining, similar to ER and PR.[15]

Scoring System	Description	Application
Percentage Positive	The percentage of tumor cells with any intensity of nuclear staining.	Primary determinant of positivity (ER/PR). A result of $\geq 1\%$ is considered positive.[1]
Allred Score	A combined score of proportion (0-5) and intensity (0-3). A total score of >2 is considered positive.	Provides semi-quantitative data for ER/PR in breast cancer.[14][16]
H-Score	Calculated as: Σ [Intensity Level (0-3) x Percentage of Cells at that Intensity]. The score ranges from 0 to 300.	Offers a continuous variable for more nuanced analysis in research settings.[14]

Table 3: Scoring Systems for Hormone Receptor Expression.

Experimental Protocols

This section provides a generalized protocol for the immunohistochemical staining of ER, PR, and AR in FFPE tissue sections. Laboratories must validate this protocol for their specific antibodies, detection systems, and equipment.

I. Specimen Preparation

- Fix tissue in 10% neutral buffered formalin for 6-72 hours.
- Process the tissue and embed in paraffin wax.
- Cut FFPE blocks into 4 μm thick sections and mount on positively charged slides.[8]
- Bake slides in an oven at 55-60°C for at least 30 minutes to ensure tissue adherence.[8]

II. Staining Protocol

Step	Reagent/Parameter	Incubation Time & Temperature	Notes
1. Deparaffinization & Rehydration	Xylene, followed by graded ethanols (100%, 95%, 70%) and distilled water	2-3 changes, 5 min each	Ensures complete removal of paraffin and rehydration of tissue.
2. Antigen Retrieval (HIER)	Citrate Buffer (pH 6.0) or EDTA Buffer (pH 9.0)	Heat to 95-100°C for 20-40 min	Critical for unmasking epitopes. ^[17] Optimal buffer and time depend on the antibody. ^[18] Pressure cookers or microwaves are common methods. ^[19]
3. Peroxidase Block	3% Hydrogen Peroxide	10 min at Room Temperature	Blocks endogenous peroxidase activity to prevent background staining. ^[20]
4. Primary Antibody Incubation	ER, PR, or AR primary antibody (see Table 2) diluted in antibody diluent	30-60 min at RT or Overnight at 4°C	Dilution must be optimized. Typical starting dilutions are 1:50 to 1:200. ^{[8][21]}
5. Detection System	HRP-polymer-based detection system	Per manufacturer's instructions	Provides signal amplification.
6. Chromogen	3,3'-Diaminobenzidine (DAB)	5-10 min at Room Temperature	Forms a brown precipitate at the antigen site. ^[20]
7. Counterstain	Hematoxylin	1-2 min at Room Temperature	Stains cell nuclei blue, providing morphological context.
8. Dehydration & Mounting	Graded ethanols, xylene, and mounting medium	Sequential immersions	Prepares the slide for coverslipping and long-term storage.

Table 4: General Immunohistochemistry Protocol Parameters.

Signaling Pathways and Experimental Workflows

Hormone Receptor Signaling Pathways

Hormone receptors are ligand-activated transcription factors that mediate the effects of steroid hormones. Their signaling can be broadly divided into genomic (slower, involving gene transcription) and non-genomic (rapid, membrane-initiated) pathways.

Estrogen Receptor (ER) Signaling: Upon binding estrogen, the ER dimerizes, translocates to the nucleus, and binds to Estrogen Response Elements (EREs) on DNA to regulate gene transcription (genomic pathway).^{[22][23]} ER can also be activated at the cell membrane, initiating rapid kinase cascades like PI3K/AKT and MAPK (non-genomic pathway).^{[24][25][26]}

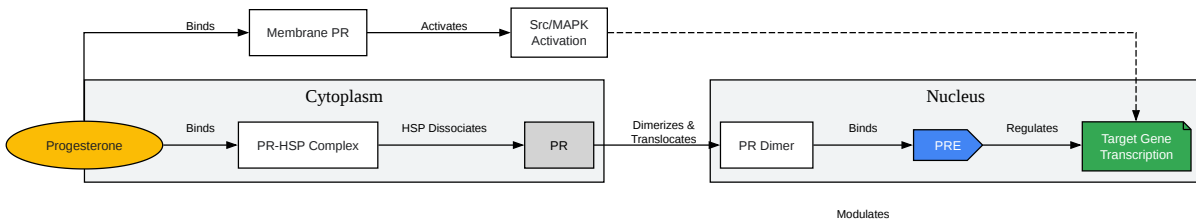
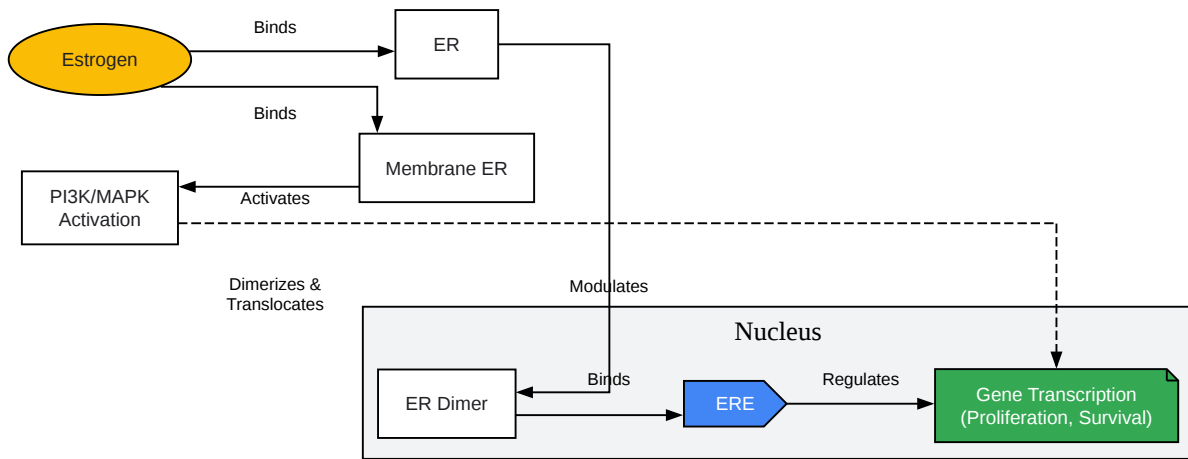

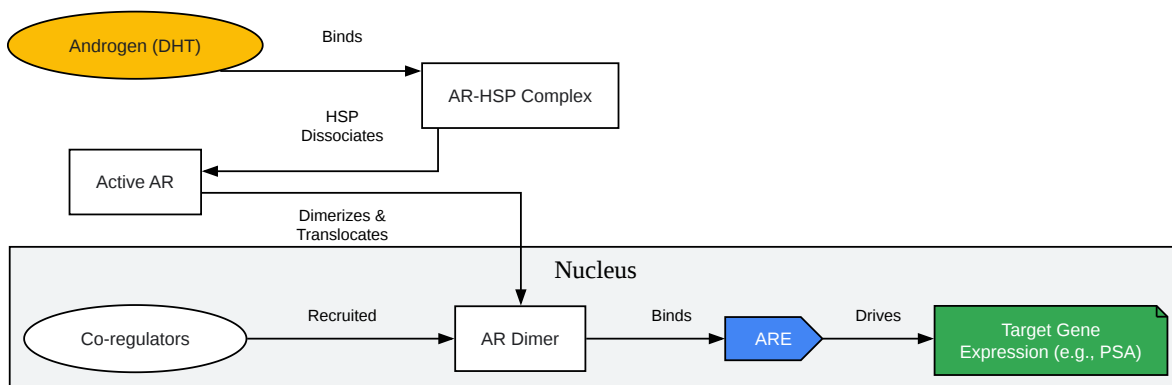

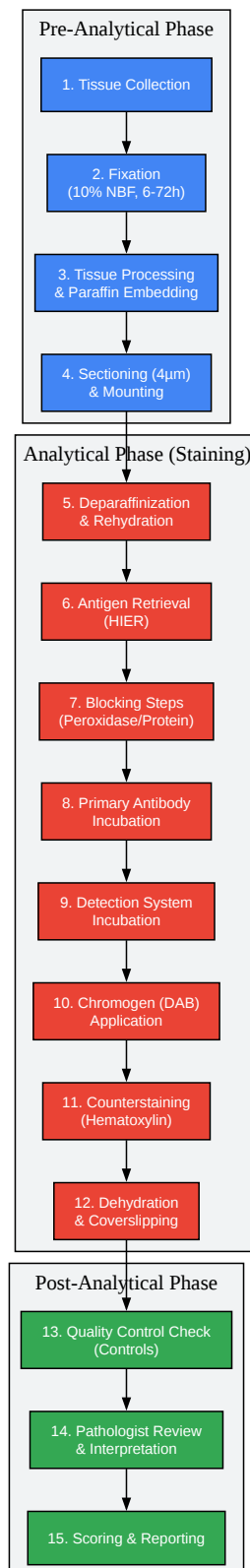

[Click to download full resolution via product page](#)

Need Custom Synthesis?

BenchChem offers custom synthesis for rare earth carbides and specific isotopic labeling.

Email: info@benchchem.com or [Request Quote Online](#).

References

- 1. Pathologists' Guideline Recommendations for Immunohistochemical Testing of Estrogen and Progesterone Receptors in Breast Cancer - PMC [[pmc.ncbi.nlm.nih.gov](https://pubmed.ncbi.nlm.nih.gov/)]
- 2. Immunohistochemical Performance of Estrogen and Progesterone Receptor Antibodies on the Dako Omnis Staining Platform: Evaluation in Multicenter Studies - PMC [[pmc.ncbi.nlm.nih.gov](https://pubmed.ncbi.nlm.nih.gov/)]
- 3. meridian.allenpress.com [meridian.allenpress.com]
- 4. Content - Health Encyclopedia - University of Rochester Medical Center [urmc.rochester.edu]
- 5. [aplm](https://aplm.kglmeridian.com/) [aplm.kglmeridian.com]
- 6. Impact of Preanalytical Factors on the Measurement of Tumor Tissue Biomarkers Using Immunohistochemistry - PMC [[pmc.ncbi.nlm.nih.gov](https://pubmed.ncbi.nlm.nih.gov/)]
- 7. Impact of pre-analytic variables on HER2 IHC results [her2know.com]
- 8. genomeme.ca [genomeme.ca]
- 9. academic.oup.com [academic.oup.com]
- 10. diagomics.com [diagomics.com]
- 11. genomeme.ca [genomeme.ca]
- 12. Immunohistochemical Evaluation of Hormone Receptors with Predictive Value in Mammary Carcinomas - PMC [[pmc.ncbi.nlm.nih.gov](https://pubmed.ncbi.nlm.nih.gov/)]
- 13. Estrogen and Progesterone Receptor... | College of American Pathologists [cap.org]
- 14. iccr-cancer.org [iccr-cancer.org]
- 15. researchgate.net [researchgate.net]
- 16. documents.cap.org [documents.cap.org]
- 17. bosterbio.com [bosterbio.com]

- 18. Strategies for improving the immunohistochemical staining of various intranuclear prognostic markers in formalin-paraffin sections: androgen receptor, estrogen receptor, progesterone receptor, p53 protein, proliferating cell nuclear antigen, and Ki-67 antigen revealed by antigen retrieval techniques - PubMed [pubmed.ncbi.nlm.nih.gov]
- 19. researchgate.net [researchgate.net]
- 20. 2.10. Immunohistochemistry of the Androgen Receptor [bio-protocol.org]
- 21. Immunohistochemical Detection of Estrogen and Progesterone Receptor and HER2 Expression in Breast Carcinomas: Comparison of Cell Block and Tissue Block Preparations - PMC [pmc.ncbi.nlm.nih.gov]
- 22. academic.oup.com [academic.oup.com]
- 23. The many faces of estrogen signaling - PMC [pmc.ncbi.nlm.nih.gov]
- 24. researchgate.net [researchgate.net]
- 25. researchgate.net [researchgate.net]
- 26. creative-diagnostics.com [creative-diagnostics.com]
- To cite this document: BenchChem. [Application Notes: Immunohistochemical Analysis of Hormone Receptor Expression]. BenchChem, [2026]. [Online PDF]. Available at: [https://www.benchchem.com/product/b1228784/docs#application-notes-immunohistochemical-analysis-of-hormone-receptor-expression]

Disclaimer & Data Validity:

The information provided in this document is for Research Use Only (RUO) and is strictly not intended for diagnostic or therapeutic procedures. While BenchChem strives to provide accurate protocols, we make no warranties, express or implied, regarding the fitness of this product for every specific experimental setup.

Technical Support: The protocols provided are for reference purposes. Unsure if this reagent suits your experiment?

Need Industrial/Bulk Grade? [Request Custom Synthesis Quote](#)

BenchChem

Our mission is to be the trusted global source of essential and advanced chemicals, empowering scientists and researchers to drive progress in science and industry.

Contact

Address: 3281 E Guasti Rd

Ontario, CA 91761, United States

Phone: (601) 213-4426

Email: info@benchchem.com

[Contact our Ph.D. Support Team for a compatibility check](#)