

Sulfo-Cyanine3 Azide: A Comprehensive Technical Guide to its Spectroscopic Properties and Applications

Author: BenchChem Technical Support Team. **Date:** April 2026

Compound of Interest

Compound Name: Sulfo-cyanine3 azide sodium

Cat. No.: B12279879

[Get Quote](#)

For Researchers, Scientists, and Drug Development Professionals

This in-depth technical guide provides a detailed overview of the core spectroscopic properties of Sulfo-cyanine3 azide, a water-soluble fluorescent probe essential for biological labeling and detection. This document outlines its excitation and emission spectra, key quantitative data, and detailed experimental protocols for its characterization and application in bioconjugation.

Core Spectroscopic and Photophysical Properties

Sulfo-cyanine3 azide is a bright, water-soluble cyanine dye equipped with an azide moiety, rendering it an ideal tool for "click chemistry" applications.^{[1][2]} Its two sulfonate groups enhance its hydrophilicity, making it suitable for labeling sensitive biological molecules in aqueous environments.^[2] The spectral properties of Sulfo-cyanine3 azide are comparable to the well-known Cy3® fluorophore.^{[1][3]}

Quantitative Data Summary

The key photophysical parameters of Sulfo-cyanine3 azide are summarized in the table below. These values are crucial for designing and interpreting fluorescence-based experiments.

Parameter	Value	Reference(s)
Excitation Maximum (λ_{ex})	548 nm	[1][3]
Emission Maximum (λ_{em})	563 nm	[1][3]
Molar Extinction Coefficient (ϵ)	162,000 M ⁻¹ cm ⁻¹	[1][3]
Fluorescence Quantum Yield (Φ_f)	0.1	[1][3]

Experimental Protocols

This section provides detailed methodologies for the characterization and application of Sulfo-cyanine3 azide.

Determination of Excitation and Emission Spectra

This protocol outlines the procedure for measuring the fluorescence excitation and emission spectra of Sulfo-cyanine3 azide using a spectrofluorometer.

Materials:

- **Sulfo-cyanine3 azide sodium salt**
- Phosphate-buffered saline (PBS), pH 7.4
- 1 cm pathlength quartz cuvette
- Spectrofluorometer with excitation and emission monochromators
- UV-Vis spectrophotometer

Procedure:

- Sample Preparation:

- Prepare a stock solution of Sulfo-cyanine3 azide in PBS.
- Dilute the stock solution with PBS to a concentration that yields an absorbance of approximately 0.1 at the absorption maximum (~548 nm) to avoid inner-filter effects.[4]
- Emission Spectrum Measurement:
 - Set the excitation wavelength of the spectrofluorometer to the absorbance maximum of the dye (e.g., 548 nm).[5]
 - Set the excitation and emission slits to an appropriate width (e.g., 2-5 nm) to balance signal intensity and spectral resolution.[4]
 - Scan the emission monochromator over a wavelength range that encompasses the expected emission, for instance, from 560 nm to 700 nm.[5]
 - Record the fluorescence intensity as a function of wavelength. The peak of this spectrum represents the emission maximum (λ_{em}).
- Excitation Spectrum Measurement:
 - Set the emission monochromator to the determined emission maximum (e.g., 563 nm).[5]
 - Scan the excitation monochromator over a wavelength range that covers the expected absorption, for example, from 450 nm to 560 nm.[6]
 - Record the fluorescence intensity as a function of the excitation wavelength. The peak of this spectrum corresponds to the excitation maximum (λ_{ex}).
- Data Correction:
 - It is crucial to correct the raw spectra for instrumental variations.[7][8] This includes correcting the excitation spectrum for the wavelength-dependent output of the light source and the emission spectrum for the wavelength-dependent sensitivity of the detector.[7][8] Modern spectrofluorometers often have built-in correction files or procedures.

Determination of Molar Extinction Coefficient

This protocol describes how to determine the molar extinction coefficient (ϵ) of Sulfo-cyanine3 azide using the Beer-Lambert law.

Materials:

- **Sulfo-cyanine3 azide sodium salt**
- High-purity solvent (e.g., PBS, pH 7.4)
- Analytical balance
- Volumetric flasks
- 1 cm pathlength quartz cuvettes
- UV-Vis spectrophotometer

Procedure:

- Prepare a Stock Solution:
 - Accurately weigh a small amount of Sulfo-cyanine3 azide and dissolve it in a known volume of solvent to create a stock solution of known concentration.[\[9\]](#)
- Prepare Serial Dilutions:
 - Perform a series of accurate dilutions of the stock solution to obtain several solutions with different known concentrations.[\[10\]](#)
- Measure Absorbance:
 - For each dilution, measure the absorbance at the wavelength of maximum absorbance ($\lambda_{\text{max}} \approx 548 \text{ nm}$) using the UV-Vis spectrophotometer.[\[11\]](#) Use the same solvent as a blank.
- Plot and Calculate:
 - Plot the absorbance at λ_{max} versus the concentration for the series of dilutions.

- The plot should yield a straight line that passes through the origin, in accordance with the Beer-Lambert law ($A = \epsilon cl$).^[12]
- The molar extinction coefficient (ϵ) is the slope of this line (when the path length, l , is 1 cm).^[12]

Determination of Fluorescence Quantum Yield (Relative Method)

This protocol details the determination of the fluorescence quantum yield (Φ_f) of Sulfo-cyanine3 azide by comparison to a standard with a known quantum yield, such as Rhodamine 6G in ethanol ($\Phi_f = 0.95$).^{[2][3]}

Materials:

- **Sulfo-cyanine3 azide sodium** salt in PBS
- Rhodamine 6G in ethanol (reference standard)
- 1 cm pathlength quartz cuvettes
- UV-Vis spectrophotometer
- Spectrofluorometer

Procedure:

- Prepare Solutions:
 - Prepare a series of dilutions for both the Sulfo-cyanine3 azide (sample) and Rhodamine 6G (reference) in their respective solvents.
 - The concentrations should be adjusted to yield absorbance values between 0.02 and 0.1 at the excitation wavelength to ensure linearity and minimize inner-filter effects.^[13]
- Measure Absorbance:

- Measure the absorbance of each solution at the chosen excitation wavelength (e.g., 528 nm for Rhodamine 6G, and a similar wavelength for the sample).
- Measure Fluorescence Emission:
 - Using a spectrofluorometer, record the corrected fluorescence emission spectrum for each solution, exciting at the same wavelength used for the absorbance measurements.
- Data Analysis:
 - Integrate the area under the corrected emission spectrum for each solution.[13]
 - Plot the integrated fluorescence intensity versus absorbance for both the sample and the reference.
 - The quantum yield of the sample ($\Phi_{\text{f_sample}}$) can be calculated using the following equation[14]:

$$\Phi_{\text{f_sample}} = \Phi_{\text{f_ref}} * (\text{Grad_sample} / \text{Grad_ref}) * (\eta_{\text{sample}}^2 / \eta_{\text{ref}}^2)$$

where:

- $\Phi_{\text{f_ref}}$ is the quantum yield of the reference standard.
- Grad_sample and Grad_ref are the gradients of the plots of integrated fluorescence intensity versus absorbance for the sample and reference, respectively.
- η_{sample} and η_{ref} are the refractive indices of the sample and reference solvents, respectively.[13]

Application: Copper(I)-Catalyzed Azide-Alkyne Cycloaddition (CuAAC)

Sulfo-cyanine3 azide is primarily used for the fluorescent labeling of alkyne-modified biomolecules via the copper(I)-catalyzed azide-alkyne cycloaddition (CuAAC) "click" reaction. [15] This reaction is highly specific and efficient, allowing for the covalent attachment of the fluorophore to proteins, nucleic acids, and other molecules.[7][16]

General Protocol for CuAAC Labeling

Materials:

- Alkyne-modified biomolecule
- Sulfo-cyanine3 azide
- Copper(II) sulfate (CuSO_4)
- Reducing agent (e.g., sodium ascorbate)
- Copper ligand (e.g., TBTA or THPTA)
- Appropriate buffer (e.g., PBS)
- DMSO (for dissolving reagents)

Procedure:

- Prepare Stock Solutions:
 - Dissolve the alkyne-modified biomolecule in an appropriate buffer.
 - Prepare a stock solution of Sulfo-cyanine3 azide in DMSO.
 - Prepare stock solutions of copper(II) sulfate, sodium ascorbate, and the copper ligand.
- Reaction Setup:
 - In a microcentrifuge tube, combine the alkyne-modified biomolecule, Sulfo-cyanine3 azide, and the copper ligand.
 - Add copper(II) sulfate to the mixture.
 - Initiate the reaction by adding a fresh solution of sodium ascorbate.[\[17\]](#)
- Incubation:

- Incubate the reaction mixture at room temperature, protected from light, for a sufficient duration (typically 30 minutes to 2 hours).[17]
- Purification:
 - Purify the labeled biomolecule from excess reagents using an appropriate method, such as size exclusion chromatography, dialysis, or precipitation.[16]

Signaling Pathway and Workflow Diagrams

The following diagrams illustrate the CuAAC reaction and a typical experimental workflow.

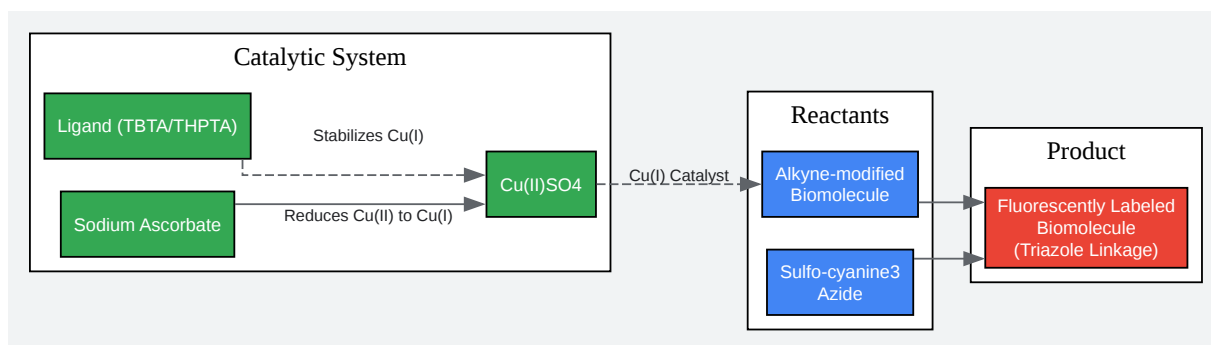

[Click to download full resolution via product page](#)

Caption: Copper(I)-Catalyzed Azide-Alkyne Cycloaddition (CuAAC) Reaction.

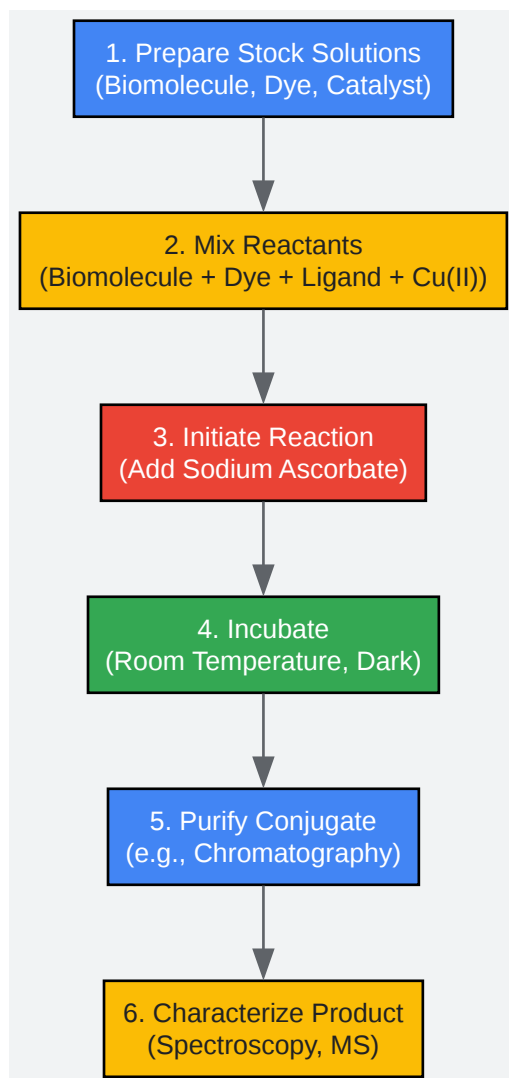

[Click to download full resolution via product page](#)

Caption: General Experimental Workflow for Bioconjugation via CuAAC.

Need Custom Synthesis?

BenchChem offers custom synthesis for rare earth carbides and specific isotopic labeling.

Email: info@benchchem.com or [Request Quote Online](#).

References

- 1. [researchgate.net](https://www.researchgate.net) [[researchgate.net](https://www.researchgate.net)]

- [2. Fluorescence quantum yields and their relation to lifetimes of rhodamine 6G and fluorescein in nine solvents: improved absolute standards for quantum yields - PubMed \[pubmed.ncbi.nlm.nih.gov\]](#)
- [3. omlc.org \[omlc.org\]](#)
- [4. edinst.com \[edinst.com\]](#)
- [5. Fluorescence Excitation and Emission Fundamentals \[evidentscientific.com\]](#)
- [6. faculty.washington.edu \[faculty.washington.edu\]](#)
- [7. researchgate.net \[researchgate.net\]](#)
- [8. edinst.com \[edinst.com\]](#)
- [9. researchgate.net \[researchgate.net\]](#)
- [10. How to Determine the Extinction Coefficient | MtoZ Biolabs \[mtoz-biolabs.com\]](#)
- [11. smart.dhgate.com \[smart.dhgate.com\]](#)
- [12. communities.acs.org \[communities.acs.org\]](#)
- [13. rsc.org \[rsc.org\]](#)
- [14. chem.uci.edu \[chem.uci.edu\]](#)
- [15. Making sure you're not a bot! \[opus4.kobv.de\]](#)
- [16. agilent.com \[agilent.com\]](#)
- [17. Experimental Determination of the Fluorescence Quantum Yield of Semiconductor Nanocrystals - PMC \[pmc.ncbi.nlm.nih.gov\]](#)
- [To cite this document: BenchChem. \[Sulfo-Cyanine3 Azide: A Comprehensive Technical Guide to its Spectroscopic Properties and Applications\]. BenchChem, \[2026\]. \[Online PDF\]. Available at: \[https://www.benchchem.com/product/b12279879/docs#sulfo-cyanine3-azide-a-comprehensive-technical-guide-to-its-spectroscopic-properties-and-applications\]](#)

Disclaimer & Data Validity:

The information provided in this document is for Research Use Only (RUO) and is strictly not intended for diagnostic or therapeutic procedures. While BenchChem strives to provide accurate protocols, we make no warranties, express or implied, regarding the fitness of this product for every specific experimental setup.

Technical Support: The protocols provided are for reference purposes. Unsure if this reagent suits your experiment?

Need Industrial/Bulk Grade? [Request Custom Synthesis Quote](#)

BenchChem

Our mission is to be the trusted global source of essential and advanced chemicals, empowering scientists and researchers to drive progress in science and industry.

Contact

Address: 3281 E Guasti Rd
Ontario, CA 91761, United States
Phone: (601) 213-4426
Email: info@benchchem.com

[Contact our Ph.D. Support Team for a compatibility check](#)